

TaJima

2026



INDEX

01 **TASCHEN-BANDMASSE**
POCKET TAPES **3-18**

02 **LASER ENTFERNMESSGERÄT**
LASER DISTANCE METER **19**

03 **LANGE BANDMASSE**
LONG TAPES **20-25**

04 **CUTTER KLINGEN**
CUTTER KNIFE BLADES **26-33**

05 **CUTTER MESSER**
CUTTER KNIVES **34-51**

06 **WECHSELKLINGEN**
UTILITY KNIFE BLADES **52**

07 **V-REX MESSER**
UTILITY KNIVES **53**

08 **SICHERHEITSMESSER**
SAFETY KNIFE **54**

09 **SPEZIAL WERKZEUGE**
SPECIALTY TOOLS **55-61**

10 **SCHABER**
SCRAPERS **62-67**

11 **HANDSÄGEN & SÄGEBLÄTTER**
HAND SAWS & BLADES **68-79**

12 **KARTUSCHENPRESSEN**
CAULK GUNS **80-85**

13 **MARKIER WERKZEUGE**
MARKING TOOLS **86-88**

14 **WERKZEUGE FÜR DEN INNENAUSBAU**
DRYWALL TOOLS **89-90**

15 **WINKELMESSER**
ANGLE METER **91**

16 **HANDLOTE**
LAYOUT TOOLS **92-93**

TASCHEN-BANDMASSE
POCKET TAPES  **01**

LASER ENTFERNMESSGERÄT
LASER DISTANCE METER  **02**

LANGE BANDMASSE
LONG TAPES  **03**

CUTTER KLINGEN
CUTTER KNIFE BLADES  **04**

CUTTER MESSER
CUTTER KNIVES  **05**

WECHSELKLINGEN
UTILITY KNIFE BLADES  **06**

V-REX MESSER
UTILITY KNIVES  **07**

SICHERHEITSMESSER
SAFETY KNIFE  **08**

SPEZIAL WERKZEUGE
SPECIALTY TOOLS  **09**

SCHABER
SCRAPERS  **10**

HANDSÄGEN & SÄGEBLÄTTER
HAND SAWS & BLADES  **11**

KARTUSCHENPRESSEN
CAULK GUNS  **12**

MARKIER WERKZEUGE
MARKING TOOLS  **13**

WERKZEUGE FÜR DEN INNENAUSBAU
DRYWALL TOOLS  **14**

WINKELMESSER
ANGLE METER  **15**

HANDLOTE
LAYOUT TOOLS  **16**



Tajima 



TASCHEN-BANDMASSE

POCKET TAPES

01



Herausragende Merkmale / Premium Features

Strong Tape



Höhere Festigkeit als bei herkömmlichen Maßbändern durch verstärkten Spezialstahl.

Extra thick steel generates more stiffness than standard tape measures.



Tethering Straps



Starke Schlaufen zum Umhängen oder zum Aufhängen an einen Haken.

Strong straps for wrist or to tether on a hook or nail.



Double-sided tapes



Beidseitig skalierte Bänder sind von allen Seiten gut lesbar

Double-sided tapes provide accurate readability for all applications.



Strong Belt Clips



Erstklassige Federstahl-Clips für dauerhafte Befestigung

Premium spring-steel belt clips for dependable performance.



Double Lock System



Das STRONG TAPE stoppt automatisch, wenn es ausgezogen ist. Um das Band zu fixieren, drücken Sie einfach die Festhalte-Taste.

Strong Tape automatically locks when extended. You only need to press Lock Button to completely fix the tape.



Safety Belt Holder



Dank Schnellverschluss kann das Gehäuse mit einer Hand am Gürtelhalter angebracht & abgenommen werden.

The quick-fit belt holder enables you to attach & detach the housing on the holder with one hand.



TASCHEN-BANDMASSE

POCKET TAPES

01

Beschichtung aus Polyestertermix / Polyester-Blend Coating



Neuartige Bandbeschichtung schützt vor Abrieb, 2 fach höherer Schutz als Standard-Beschichtungen

Innovative tape coating provides advanced protection against abrasion, 2 times greater than standard tape coatings.



Zustand des Bandes nach Abrieb-Simulation

Tape condition after abrasive-wear simulation



Tajima



A



B



Hochwertige Endhaken / Superior End Hook

Unique 3-Rivet Attachment



3fach genieteteter Endhaken mit einer unabhängig befestigten Stahlplatte

Triple-riveted end hook secured with an independently riveted steel back plate.

Reliable Self-Adjustment

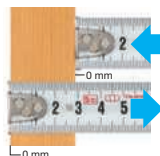

Frei bewegbarer Endhaken garantiert konstant exakte Aussen- und Innenmessungen

Freely moving end hook ensures consistently accurate inside and outside measurements.

Strong Hook



Extra starker Haken mit 1,6 mm und mit 4,7 mal längerer Haltbarkeit als bei Standardmodellen

Thickness 1.6 mm 4.7 times stronger than standard model.

Ultra Hard End Hook



Einzigartig gehärteter Endhaken mit doppeltem Härtegrad im Vergleich zu gewöhnlichen Endhaken

Unique tempered steel end hooks are twice as hard and durable as traditional end hooks.

Magnetic End Hook



Kraftvolle Magnete mit Magnetkraft von 2600 GB

Powerful twin rare-earth magnets generate 2600 Gb of magnetic hold.

Double Magnetic















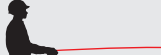





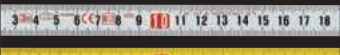





















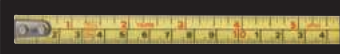

Einmalige Magnetschiene und magnetischer Endhaken

Unique magnetic base tapemeasures with magnetic end hooks

TASCHEN-BANDMASSE

POCKET TAPES

01

	 Width					
EC Class 1	16 mm	standard tape			1.5m	2.3m
	25 mm	standard tape			2.4m	3.8m
EC Class 2  Double-sided tapes	16 mm	standard tape			1.5m	2.3m
	19 mm	standard tape			1.8m	2.8m
	25 mm	standard tape			2.4m (10m : 2.1m)	3.8m (10m : 3.4m)
		Strong Tape 			2.4m	3.6m
		Strong Tape 			2.6m	3.9m
	27 mm	Strong Tape 			2.7m	4.0m
EC Class 2	13 mm	standard tape			1.2m	1.6m
	16 mm				1.5m	2.3m
	19 mm				1.8m	2.8m
	25 mm				2.4m (10m : 2.1m)	3.8m (10m : 3.4m)
JIS 1	13 mm	standard tape			1.2m	1.6m
	22 mm				2.1m	3.4m
Dual Tape (m/ft)	13 mm	standard tape			1.2m	1.6m
	25 mm	Strong Tape 			2.6m	3.9m
	27 mm	Strong Tape 			2.7m	4.0m

Genauigkeit Bei Bandmassen Aus Stahl
Steel Tape Measurement Accuracy

	2 m	3 m	5 m	8 m	10 m
Class 1 (mm)	± 0.4	± 0.5	± 0.7	± 1.0	± 1.2
Class 2 (mm)	± 0.9	± 1.1	± 1.5	± 2.1	± 2.5

	2 m	3.5 m	5.5 m
JIS 1 (mm) ※	± 0.6	± 0.8	± 1.0

※Japanese Industrial Standards

TASCHEN-BANDMASSE

POCKET TAPES

01

GS-LOCK

EXTRA STIFF

Armored Case
Stoßfestes Panzergehäuse schützt das Gehäuse vor Aufprall bei versehentlichem Fallenlassen

Shock-resistant armored case protects the housing from impact during inadvertent dropping.

Safety Rope Tether Mount With Ring
Verhindert Fallenlassen oder Verlegen

Prevents dropping or mislaying.

End Hook Guard
Eine dicke Elastomerhülle erstreckt sich um den Körper des Maßbandes herum, um Endhaken und Arbeitsflächen zu schützen.

Thick elastomer case armor extends around the body of the tape measure to protect end hooks and work surfaces.

GS-Lock



MEASURING TAPE WITH DOUBLE METRIC AND INCH GRADUATION



Art.Nr.		Tape Measurement Accuracy	CASE	MASTER CARTON	EAN	Weight (g) (Packaging + Product)
GAG3L25-50D-EUR	25 mm	5.0 m/16 ft	6	30 (5 SETS)	4975364 122735	2,543 (368/pc)
GAG3L27-75D-EUR	27 mm	7.5 m/25 ft			4975364 122742	3,798 (570/pc)

TASCHEN-BANDMASSE

POCKET TAPES

01

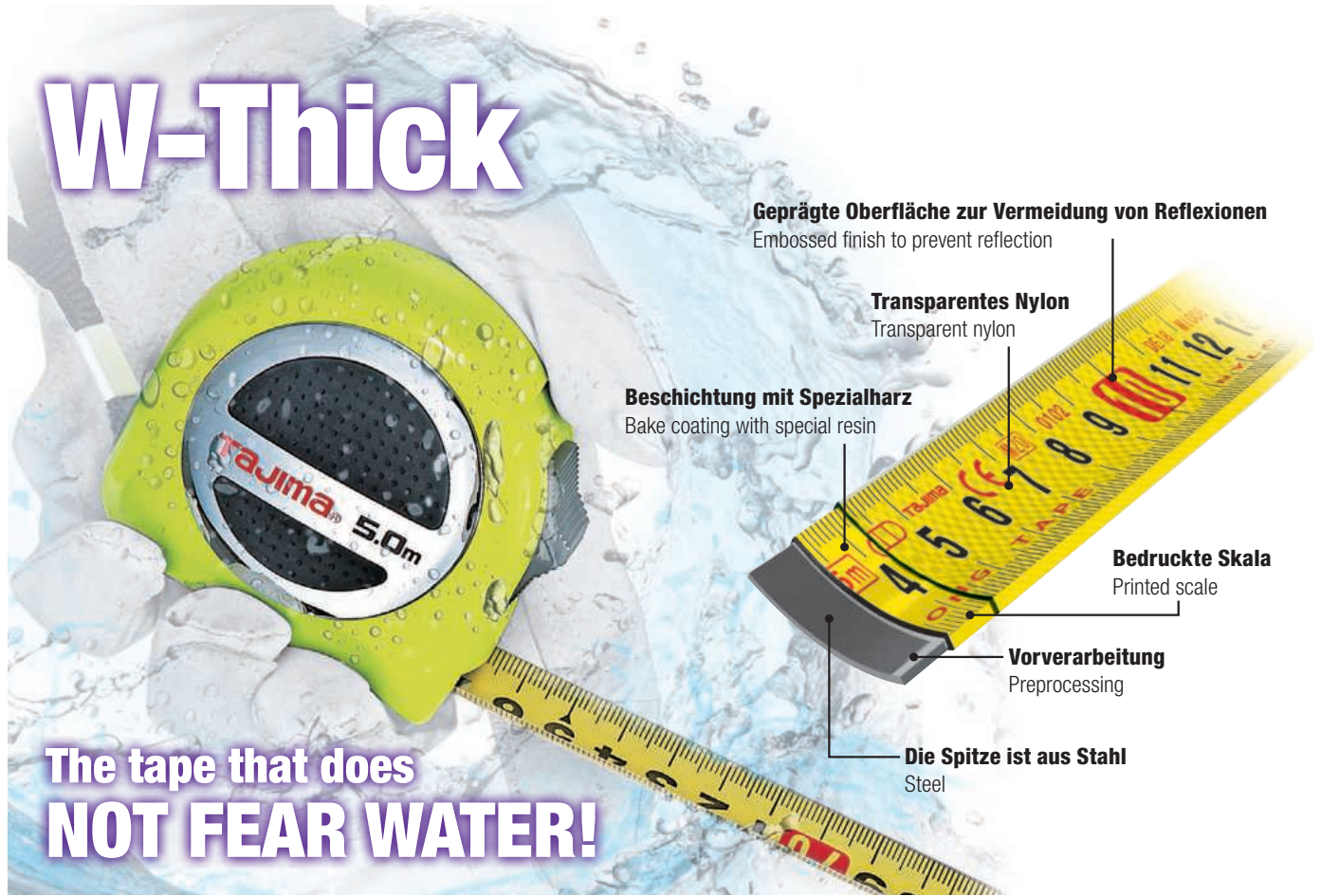

W-Thick

The tape that does **NOT FEAR WATER!**

Geprägte Oberfläche zur Vermeidung von Reflexionen
Embossed finish to prevent reflection

Transparentes Nylon
Transparent nylon

Beschichtung mit Spezialharz
Bake coating with special resin

Bedruckte Skala
Printed scale

Vorverarbeitung
Preprocessing

Die Spitze ist aus Stahl
Steel

W-Thick



Die Feder besteht aus rostfreiem Edelstahl, welche die Wicklung deutlich verbessert.

The spring is made of rust-resistant stainless, greatly improved winding problems.



Leistungsvergleich W-Thick

W-Thick performance comparison

Product	W-Thick	A	B	C
Tape coating	Nylon (coating)	Nylon (painting)		
Tape length x width	5 m x 25 mm	8 m x 25 mm	5 m x 19 mm	5 m x 16 mm
Tape wear resistance ※ 1	 1,000 or more reciprocations	 Less than 50 reciprocations	 Less than 150 reciprocations	 Less than 50 reciprocations
Superior Stand-Out	2.3 m	2.2 m	2.1 m	1.1 m
Rigidity (N) ※ 2	Front surface	8.2	5.5	3.9
	Back surface	37.2	26.7	18.6
Hook strength (N) ※ 3	1,503	586	612	909

※1 They let an eraser made of sand go and back on a tape. The number indicates "how many times" an eraser did this action until the scale will be unreadable.

※2 This is our own/original way of showing how rigid the tape is, not will be bent or warped. The number indicates the force exactly the moment when tape snaps by being added force.

※3 It indicates the maximum strength of the nail by falling. It means, you drop Conve (tape sorted inside) but still the nail will not be broken.



Art.Nr.		Tape Measurement Accuracy	CASE	MASTER CARTON	EAN	Weight (g) (Packaging + Product)
GASP25-50EB-EUR	25 mm 5 m	EC Class 2	6	30 (5 SETS)	4975364 122063	2,287 (358/pc)

TASCHEN-BANDMASSE

POCKET TAPES

01



Hi-LOCK



Premium Bandmass der Klasse 1.

Class 1 premium measuring tape.

Hi-Lock CLASS 1 16mm



Hi-Lock CLASS 1 25mm



Genauigkeit Bei Bandmassen Aus Stahl
Steel Tape Measurement Accuracy

	Class 1 (mm)	Class 2 (mm)
2 m	± 0.4	± 0.9
3 m	± 0.5	± 1.1
5 m	± 0.7	± 1.5
8 m	± 1.0	± 2.1
10 m	± 1.2	± 2.5



Art.Nr.	Tape Measurement Accuracy		CASE	MASTER CARTON	EAN	Weight (g) (Packaging + Product)
	2 3 4 5 6 7 8					
L16-30E1-EUR	16 mm	3 m	EC Class 1	6	4975364 122056	128
L25-50E1-EUR	25 mm	5 m				

TASCHEN-BANDMASSE

POCKET TAPES

01



Auto Stop & Strong Lock

Double Lock System



Auto Stop

Das selbstblockierende System hält das Band auf der gewünschten Länge.

It is a self blade locking system which keeps the tape stretched out at the length you need.



Strong Lock Button

Für eine zusätzlich verbesserte Arretierkraft des Bands.

Further strengthens the fixing force of the tape.



Retract Button

Drücken Sie die Taste mit Unterbrechung um das Band einzurollen.

Press the button intermittently and retract the tape.

Sigma Stop



Art.Nr.		Tape Measurement Accuracy	CASE	MASTER CARTON	EAN	Weight (g) (Packaging + Product)
SSS16-30EB-EUR	16 mm 3 m	EC Class 2	6	30 (5 SETS)	4975364 125835	190
SSS19-50EB-EUR	19 mm 5 m				4975364 125842	274

TASCHEN-BANDMASSE

POCKET TAPES

W-MAG

Einmalige Magnetschiene und magnetischer Endhaken, für einhändige Bedienung im Stahl- und Rohrbau, bei Klempner- und Sanitärarbeiten. arkeit von Vorder- und Rückseite.

Unique magnetic base tape measures with magnetic end hooks designed for fast one-person measurements in plumbing, steel stud framing, and metal fabrication applications.



image

W-MAG



More info



Art.Nr.		Tape Measurement Accuracy	CASE	MASTER CARTON	EAN	Weight (g) (Packaging + Product)
G3GLWM25-50EB-EUR	25 mm 5 m	EC Class 2	6	30 (5 SETS)	4975364 120366	2,344 (358/pc)

TASCHEN-BANDMASSE

POCKET TAPES

01

W-MAG Safety Belt Holder



**CLIP-
n-
HOLD**



Dank Schnellverschluss kann das Gehäuse mit einer Hand am Gürtelhalter angebracht & abgenommen werden.

The quick-fit belt holder enables you to attach & detach the housing on the holder with one hand.

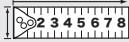

Art.Nr.			Tape Measurement Accuracy	CASE	MASTER CARTON	EAN	Weight (g) (Packaging + Product)
SFG3GLWM2570EB-EUR	25 mm	7 m	EC Class 2	6	24 (4 SETS)	4975364 125828	3,496 (551/pc)

Safety Belt Holder



**CLIP-
n-
HOLD**



- Ermöglicht einhändiges Einhängen/Aushaken
- Verhindert das Fallenlassen oder Verlegen

- Allows one-handed hooking/unhooking
- Prevents from dropping or mislaying

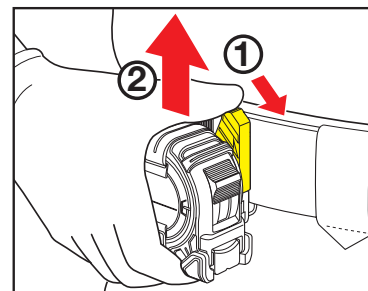

- ① **Knopf drücken und halten** Press & Hold Button
② **Anheben** Lift up

Wearable Adjustable Belt Sizes

Up to 60 mm wide
Up to 5.5 mm thick

Art.Nr.	CASE	MASTER CARTON	EAN	Weight (g) (Packaging + Product)
SF-BHLD-EUR	6	60	4975364 122780	42

TASCHEN-BANDMASSE

POCKET TAPES

G³-LOCK

Erstklassige Bandmasse entwickelt für aussergewöhnlich langen Bandauszug, magnetisches Anhaften des Endhakens und exzellente Ablesbarkeit von Vorder- und Rückseite.

Premium tape measures designed for applications requiring superior stand-out, magnetic tape attachment and accurate scale readability from either side of the tape.



Strong Tape

Höhere Festigkeit als bei herkömmlichen Maßbändern durch verstärkten Spezialstahl.

Extra thick steel generates more stiffness than standard tape measures.



G3-Lock



CONVEX-SET1

- G3-Lock 27mm 5 m
- Dorafin Quick Back
- Razar Black Blade



Art.Nr.		Tape Measurement Accuracy	CASE	MASTER CARTON	EAN	Weight (g) (Packaging + Product)	
G3GLM27-50EB-EUR	27 mm	5 m	6	30 (5 SETS)	4975364 029782	2,544 (392/pc)	
G3GLM27-80EB-EUR		8 m			EC Class 2	4975364 029973	3,710 (585/pc)
CONVEX-SET1		5 m				4975364 076168	4,004 (620/pc)

TASCHEN-BANDMASSE

POCKET TAPES

01

Z-LOCK

Antirutsch-Ummantelung
Non-Slip Elastomer Grip



Endhaken Schutz
Hook Guard Bumper



Feststell-Bremse
zum Feintuning der
Rücklaufgeschwindigkeit.

Recoil Brake
to safely control recoil speed.

Strong Tape

Höhere Festigkeit als bei herkömmlichen
Maßbändern durch verstärkten Spezialstahl.

Extra thick steel generates more stiffness than
standard tape measures.

Z-LOCK



Art.Nr.		Tape Measurement Accuracy	CASE	MASTER CARTON	EAN	Weight (g) (Packaging + Product)
ZL25-50EB-EUR	25 mm	5 m	6	30 (5 SETS)	4975364 120922	2,340 (358/pc)
ZL25-80EB-EUR		8 m				EC Class 2

TASCHEN-BANDMASSE

POCKET TAPES

01

G-LOCK



**3 fach senkrecht
Endhaken**
Strong Triple Riveted
End Hook

Endhaken Schutz
Hook Guard Bumper

Antirutsch-Ummantelung
Non-Slip Elastomer Grip



Shock Resistant

**Sturzresistent, also kein
Verkratzen der Oberfläche
bei Herunterfallen**

Drop-resistant, so no scratches
on surface finish even if dropped

G-LOCK



G Lock Pyramiden-Aufsteller
G Lock Pyramid Set



GLPYR-SET2 **GLPYR-SET3**
• G-LOCK 25mm 5 m x 16 • G-LOCK 25mm 5 m x 24
• G-LOCK 25mm 7 m x 8

Art.Nr.			Tape Measurement Accuracy	CASE	MASTER CARTON	EAN	Weight (g) (Packaging + Product)
GL16-30E -EUR	16 mm	3 m	EC Class 2	6	60	4975364 026552	154
GL19-50EB -EUR	19 mm	5 m			30 (5 SETS)	4975364 024800	1,798 (268/pc)
GL25-50EB -EUR	25 mm	5 m			30 (5 SETS)	4975364 024695	2,092 (316/pc)
GL25-70EB -EUR		7 m			30 (5 SETS)	4975364 024718	2,868 (446/pc)

Art.Nr.			Tape Measurement Accuracy	CASE	MASTER CARTON	EAN	Weight (g) (Packaging + Product)
GL25-80EB -EUR	25 mm	8 m	EC Class 2	6	30 (5 SETS)	4975364 026705	3,178 (497/pc)
GL25-100EB -EUR		10 m				4975364 025296	3,818 (603/pc)
GLPYR-SET2		5 m 7 m				4975364 026101	8,050
GLPYR-SET3	5 m			24	48	4975364 120595	7,050

TASCHEN-BANDMASSE

POCKET TAPES

01

G-Lock Dual graduation (m/ft)

MEASURING TAPE WITH DOUBLE METRIC AND INCH GRADUATION



Art.Nr.		Tape Measurement Accuracy	CASE	MASTER CARTON	EAN	Weight (g) (Packaging + Product)
GL25-50D-EUR	25 mm	5 m/16 ft	6	30 (5 SETS)	4975364 122759	2,237 (317/pc)
GL25-75D-EUR		7.5 m/25 ft			4975364 122766	3,162 (470/pc)
GL25-100D-EUR		10 m/33 ft			4975364 122773	3,903 (583/pc)

Magnet-G



Mit extrastarkem Gehäuseschutz, magnetischem Endhaken und Stossdämpfer im geschützten Gehäuse.

Shock resistant measuring tapes with magnetic end hooks and cushioned end hook returns, in armored cases.

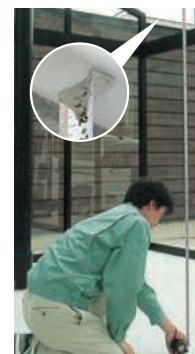

Art.Nr.		Tape Measurement Accuracy	CASE	MASTER CARTON	EAN	Weight (g) (Packaging + Product)
GLM25-50EB-EUR	25 mm	5 m	6	30 (5 SETS)	4975364 028426	2,092 (316/pc)

TASCHEN-BANDMASSE

POCKET TAPES

01

Hi-LOCK



Ergonomisch ausgereift und zuverlässig in der Handhabung, kompaktes und robustes ABS-Gehäuse.

Smooth and dependable measuring tapes in compact and ergonomic ABS cases.

Hi-Lock



Art.Nr.			Tape Measurement Accuracy	CASE	MASTER CARTON	EAN	Weight (g) (Packaging + Product)
L16-30E-EUR	16 mm	3 m	EC Class 2	6	60	4975364 010742	132
L16-50E-EUR						4975364 010803	201
L19-50EB-EUR	19 mm	5 m			48 (8 SETS)	4975364 011077	1,594 (234/pc)
L25-50EB-EUR	25 mm				48 (8 SETS)	4975364 011350	1,902 (285/pc)
L25-70EB-EUR		7 m			48 (8 SETS)	4975364 011398	2,562 (395/pc)
L25-100E-EUR		10 m			30	4975364 024220	542

TASCHEN-BANDMASSE

POCKET TAPES

01

Top-Conve

Belt Clip Type



TAJIMA's Original mit Auto-Stop-Funktion. Hält das Band automatisch bei jeder Länge.

Tajima's original Auto Stop measuring tapes that automatically hold the tape at any extension.

Art.Nr.		Tape Measurement Accuracy	CASE	MASTER CARTON	EAN	Weight (g) (Packaging + Product)	
TOP13-20EK-EUR	13 mm	2 m	EC Class 2	6	120	4975364 011558	86
TOP13-30EK-EUR		3 m				4975364 011596	121
TOP13-35EK-EUR		3.5 m			60	4975364 011626	134
TOP13-50EK-EUR		5 m				4975364 011664	166

Top-Conve



TAJIMA's Original mit Auto-Stop-Funktion. Hält das Band automatisch bei jeder Länge.

Tajima's original Auto Stop measuring tapes that automatically hold the tape at any extension.

Genauigkeit Bei Bandmassen Aus Stahl
Steel Tape Measurement Accuracy

	JIS 1 (mm)
2 m	± 0.6
3.5 m	± 0.8
5.5 m	± 1.0

Art.Nr.		Tape Measurement Accuracy	CASE	MASTER CARTON	EAN	Weight (g) (Packaging + Product)	
TOP13-20N-EUR	13 mm	2 m	JIS	6	120	4975364 025111	82
TOP13-35N-EUR		3.5 m				4975364 025128	127
TOP13-55N-EUR		5.5 m			60	4975364 025135	173

Hi-Conve



Ergonomisches Bandmass mit perfektem Passsitz und gleichmäßigem Bandvor- und rücklauf ohne Stopptaste.

Ergonomic measuring tapes fit comfortably in hand, deliver smooth and consistent rewind.

Art.Nr.		Tape Measurement Accuracy	CASE	MASTER CARTON	EAN	Weight (g) (Packaging + Product)	
H13-20EN-EUR	13 mm	2 m	EC Class 2	6	120	4975364 125712	77

TASCHEN-BANDMASSE

POCKET TAPES

01

My-Conve



MEASURING TAPE WITH DOUBLE METRIC AND INCH GRADUATION

Klassische Form mit TAJIMA's Auto-Stop-System. Hält das Band automatisch bei jeder Länge.

Rectangular-shaped measuring tapes with Tajima's Auto Stop that automatically holds the tape at any extension.



Art.Nr.			Tape Measurement Accuracy	CASE	MASTER CARTON	EAN	Weight (g) (Packaging + Product)
	13 mm	2 m / 6 ft					
NMY13-20D-EUR	13 mm	2 m / 6 ft	—	6	120	4975364 011718	92

Pit-Measure

Stahl-Bandmass mit Selbstklebefolie auf der Rückseite zur Befestigung auf Oberflächen.

Adhesive-backed measuring tapes.



Right base point (PIT-30FRC-EUR)

Art.Nr.			Tape Measurement Accuracy	CASE	MASTER CARTON	EAN	Weight (g) (Packaging + Product)
	13 mm	1 m / 2 m / 5 m / 3 m					
PIT-10C-EUR	13 mm	1 m	—	6	120	4975364 125781	27
PIT-20C-EUR		2 m				4975364 125798	43
PIT-50C-EUR		5 m				4975364 125804	85
PIT-30FRC-EUR		3 m				4975364 122216	56

LASER ENTFERNMUNGSMESSGERÄT

LASER DISTANCE METER

02



Einfache Handhabung, Präzise Ergebnisse

Schnelle Längenmessungen und automatische Addition zum Gesamtergebnis, Raum-Volumenfeste Optik, keine beweglichen Teile, scharf abgegrenzter Zielpunkt.

Simple Operation, Precise Results

Quickly measures distances and computes total area, volume, more.

Laser Distance Meter

F05

Laser Distance Meter F05



Optionen für den 0-Punkt
Starting Point Options

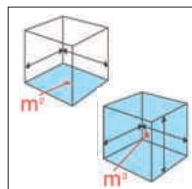

Fläche und Raumvolumen
Compute total area or volume

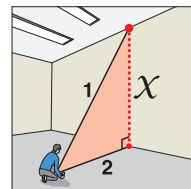

Pythagoras-Funktion
Pythagoras

Zwei und Dreipunkt-Pythagoras-Funktion.
Two or three point pythagoras.

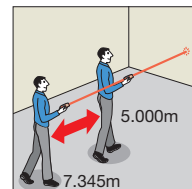

Dauermessung und bewegliche Messung
Continuous Measuring

Zubehör
-Original TAJIMA-Schutztasche
-Zwei AAA Batterien

Accessories
-Protective Case
-Two AAA batteries

Art.Nr.	Measurement range	TOLERANCE ACCURACY	CASE	MASTER CARTON	EAN	Weight (g) (Packaging + Product)
LKT-F05R	0.05 m – 50 m	± 2.0 mm	-	10	4975364 048660	239

Laser Distance Meter F02



Optionen für den 0-Punkt
Starting Point Options

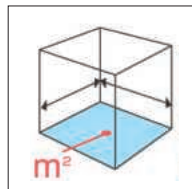

Flächenberechnung
Compute total area

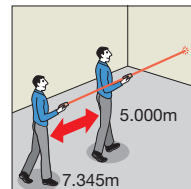

Dauermessung und bewegliche Messung
Continuous Measuring



Leicht und kompakt
Lightweight and Compact

Zubehör
-Tasche
-Zwei AAA Batterien

Accessories
-Pouch
-Two AAA batteries

Art.Nr.	Measurement range	TOLERANCE ACCURACY	CASE	MASTER CARTON	EAN	Weight (g) (Packaging + Product)
LKT-F02R	0.2 m – 20 m	± 3.0 mm	-	10	4975364 048646	183

LANGE BANDMASSE

LONG TAPES

Engineer

03



BAND-SKALIERUNG

TAPE CALIBRATION

			Erhältlich Available for
10 mm (0.18 mm)	Weisses Band mit Polyester- Coating		ENGINEER POCKET
13 mm (0.23 mm)	White polyester-blend coated tape		ENGINEER TEN
10 mm (0.44 mm)	Band mit Nylon Coating Nylon coated tape		ENGINEER SUPER

BAND-STRUKTURTAPE COMPOSITION

Die Polyester-Beschichtung schützt das Band und verbessert den Bandauszug.

- ① Kern aus gehärtetem Stahl
- ② Oberfläche speziell behandelt
- ③ Dauerhafte Bedruckung
- ④ Robustes Nylon-Coating

WHITE POLYESTER-BLEND COATED TAPE

Polyester-blend coating protects the tape and improves tape stand-out.

- ① High grade tool steel core
- ② Surface treatment
- ③ Accurate, long lasting printing
- ④ Tough, polyester-blend coating

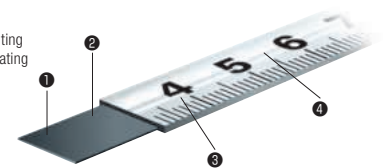

NYLON-BESCHICHTETE STAHLBÄNDER

Das harte Nylon-Coating auf der Oberseite des Polyestergewebes schützt das Band vor Rost, macht es kratzfest und verbessert den Bandauszug.

- ① Kern aus gehärtetem Stahl
- ② Oberfläche speziell behandelt
- ③ Robustes Nylon-Coating
- ④ Präzise und dauerhafte Bedruckung
- ⑤ Klare Nylon-Schicht
- ⑥ Spezielle Oberflächenbehandlung verhindert Lichtreflexionen

NYLON COATED STEEL TAPES

A tough nylon coating is applied on top of the polyester-blend coated tape making it rust and scratch resistant and improving tape stand-out.

- ① High grade tool steel core
- ② Surface treatment
- ③ Tough, polyester-blend coating
- ④ Accurate, long lasting printing
- ⑤ Clear nylon coating
- ⑥ Embossed finish reduces glare

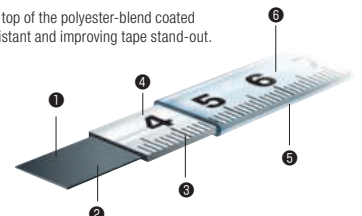

BAND-ANFANG TYPES OF ZERO-POINTS

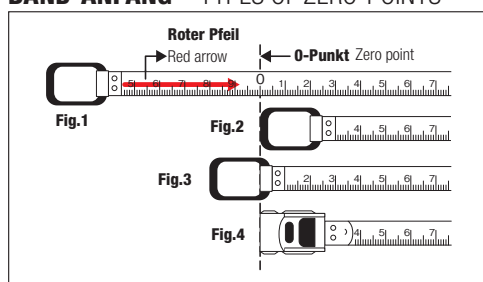

LANGE BANDMASSE

LONG TAPES

Engineer Ten



Leichtgängiges und zuverlässiges Stahl-Bandmass auf robustem Drehkreuz. Für präzises Messen grosser Distanzen.

Smooth and dependable open-reel steel tape measures designed for accurate long-distance measuring.

03

Art.Nr.				Tape Measurement Accuracy	CASE	MASTER CARTON	EAN	Weight (g) (Packaging + Product)
HTN30MW2A01	13 mm	30 m	Fig.2	JIS	-	10	4975364 042057	1,074
HTN30MW3A10			Fig.3	No class EC			4975364 037336	
HTN50MW2A01		50 m	Fig.2	JIS			4975364 042064	1,500
HTN50MW3A10			Fig.3	No class EC			4975364 037381	

Engineer Super



Premium-Stahlbandmass mit offenem ABS-Rahmen. Das Nylon-Coating macht das 10 mm breite Band resistent gegen Wasser und Chemikalien.

Premium open-reel steel tape measures with 10 mm wide nylon coated tapes that resist damage from water or jobsite chemicals.

Art.Nr.				Tape Measurement Accuracy	CASE	MASTER CARTON	EAN	Weight (g) (Packaging + Product)
HSP30MW3A10	10 mm	30 m	Fig.3	No class EC	-	10	4975364 037220	835
HSP50MW3A10		50 m					4975364 037282	1,138

LANGE BANDMASSE

LONG TAPES

Engineer Pocket

03



Starkes und kompakt aufgewickeltes Stahl-Bandmass. In leichtem und schlagfestem ABS-Gehäuse.

Strong closed-reel steel tape measures in lightweight yet durable ABS cases.

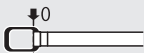
Art.Nr.			Tape Measurement Accuracy	CASE	MASTER CARTON	EAN	Weight (g) (Packaging + Product)				
EPK10MW1E01	10 mm	10m	Fig.1	JIS	4	40	195				
EPK10MW2E01			Fig.2	JIS				–			
EPK10MW3E10			Fig.3	No class EC				4975364 037053			
EPK10MW4E01			Fig.4	JIS				–			
EPK20MW1E01		20m	Fig.1	JIS			4	40	316		
EPK20MW2E01			Fig.2	JIS						–	
EPK20MW3E10			Fig.3	No class EC						4975364 037107	
EPK20MW4E01			Fig.4	JIS						4975364 012579	
EPK30MW1E10		30m	30m	Fig.1			No class EC	4	40	440	
EPK30MW3E10				Fig.3			No class EC				4975364 037152
EPK30MW4E01				Fig.4			JIS				4975364 037169
EPK30MW4E01										–	

LANGE BANDMASSE

LONG TAPES

Symron

03



BAND-SKALIERUNG

TAPE CALIBRATION

BAND-SKALIERUNG		TAPE CALIBRATION		Erhältlich Available for
13 mm (0.52 mm)	Metric (2mm/5mm)	JIS		SYMRON-L SYMRON-R SYMRON-S
	Metric (EC)	EC Class 3		

BAND-STRUKTUR TAPE COMPOSITION

SYMRON Fiberglas Bandmasse

- ① Fiberglas Fasern über die ganze Bandbreite
- ② Spezieller Kunstharzüberzug
- ③ Präziser Druck der Skalierung
- ④ Transparente PVC-Beschichtung
- ⑤ Spezielle Oberfläche verhindert Lichtreflexionen

Symron fiberglass tapes
Characteristics of PVC-coated fiberglass tape.

- ① Fiberglass strands throughout the entire width
- ② Special resin paint
- ③ Accurate printed scales
- ④ Transparent PVC coating
- ⑤ Embossed finish reduces glare

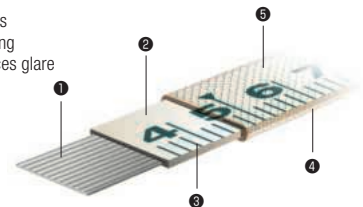

BAND-ANFANG

TYPES OF ZERO-POINTS

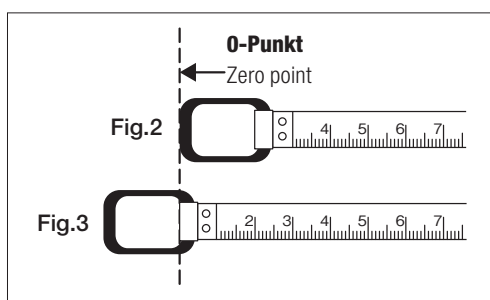

● Fig. 3 entsprechen der EC-Klasse 3

● Fig. 3 Zero Point conform to EC Class 3 regulations

TAJIMA'S SYMRON Fiberglas Bandmasse sind nicht stromleitend. Sie sind mit klarem PVC beschichtet. Dadurch besitzen sie eine 100fach höhere Strapazierfähigkeit als unbeschichtete Bänder. Die weissen und gelben Bänder erleichtern die Lesbarkeit der Skalierung und verhindern falsches Aufwickeln. Weiss = Stahlbänder Gelb = Fiberglas

Tajima Symron Fiberglass Tapes are electrically non-conductive and feature a transparent PVC coating. This special coating makes Tajima tapes over 100 times more resistant to wear. White / Yellow color coding aids scale identification and helps prevent tape twist during rewind.

LANGE BANDMASSE

LONG TAPES

Symron-L

03



Fiberglas-Bandmass in halb offenem ABS-Gehäuse mit spezieller PVC-Beschichtung.

Semi closed-reel fiberglass tape measures with protective PVC tape coatings.

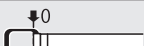

Art.Nr.			Tape Measurement Accuracy	CASE	MASTER CARTON	EAN	Weight (g) (Packaging + Product)	
SYL30MTBG01E	13 mm	30 m	Fig.2	JIS	4	12	4975364 034892	575
SYL50MT3G15		50 m	Fig.3	EC Class 3			4975364 034908	835

Symron-R



Fiberglas-Bandmass in offener Leichtbauweise mit spezieller PVC-Beschichtung.

Open-reel fiberglass tape measures with protective PVC tape coatings.

Art.Nr.			Tape Measurement Accuracy	CASE	MASTER CARTON	EAN	Weight (g) (Packaging + Product)	
SYR30MT3G15	13 mm	30 m	Fig.3	EC Class 3	4	12	4975364 034915	560
SYR50MT3U15TAG		50 m					-	820

LANGE BANDMASSE

LONG TAPES

Symron-S

Fiberglas-Bandmass in geschlossenem ABS-Gehäuse mit spezieller PVC-Beschichtung.

Closed-reel fiberglass tape measures with protective PVC tape coatings.

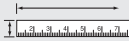
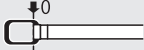

Art.Nr.			Tape Measurement Accuracy	CASE	MASTER CARTON	EAN	Weight (g) (Packaging + Product)	
SYS20MT2E01E	13 mm	20 m	Fig.2	JIS	4	24	4975364 035059	380
SYS20MT3U15TAG		20 m	Fig.3	EC Class 3	4	24	-	380
SYS50MT3B15		50 m			-	10	4975364 035073	745

CUTTER KLINGEN

CUTTER KNIFE BLADES

04

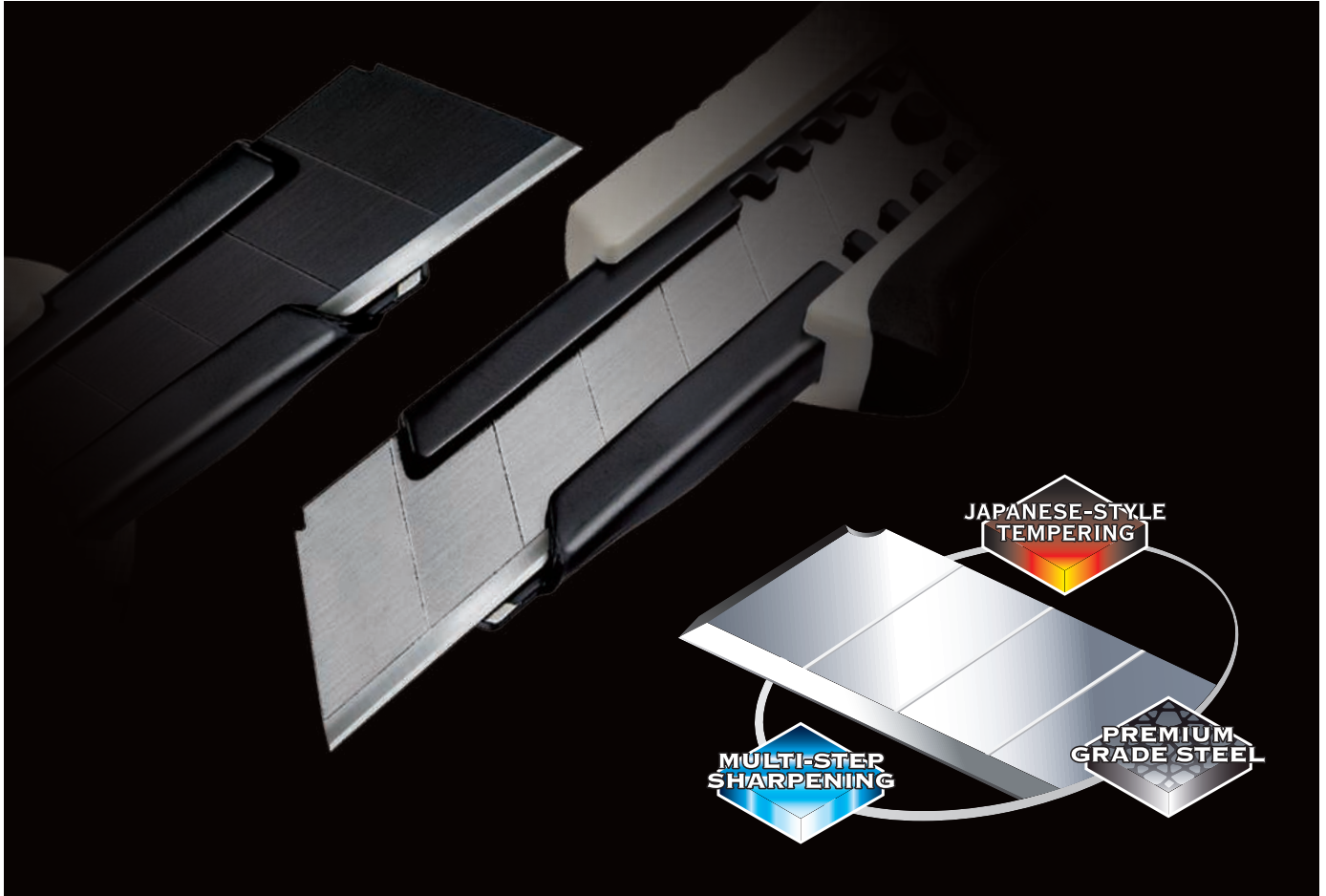

Die höchste einsetzbare Stahlqualität garantiert die maximale Stahl-Härte und führt dadurch zu einem Optimum an Klingenschärfe.

The purest grade of steel ensures the strongest-possible core and results in a more accurately tooled and sharpened blade.



Das Know How von Wärmebehandlung und Härteverfahren garantieren die maximale Klingenschärfe und Haltbarkeit.

A centuries-old process of heat-treating and hardening the steel to further maximize blade strength and cutting edge life.



Die optimale Klingengeometrie und der Einsatz der neusten Schleiftechnik führt zu der einmaligen Klingenschärfe.

Optimized cutting edge geometry and advanced honing techniques results in consistent, superior cutting performance.

CUTTER KLINGEN

CUTTER KNIFE BLADES

High durability



Endura-Blade

Für universelle Cutter-Anwendung ideal für Gipskartonplatten, Holz und andere dicke Materialien. Sehr scharfe und stabile Klinge. Durch die perfekte Kombination über Premium-Stahl, japanischer Vergütungs-Technologie und mehrstufigem Schärfen-Prozess wird eine dauerhafte und exzellente Schneide-Leistung erzielt.

For general purpose scoring and cutting, ideal for work with Drywall, Wood and other Thick Materials. An extremely sharp and strong blade that integrates premium steel, Japanese-style tempering and multi-step sharpening to produce a dependable, solid feel and long cutting performance.

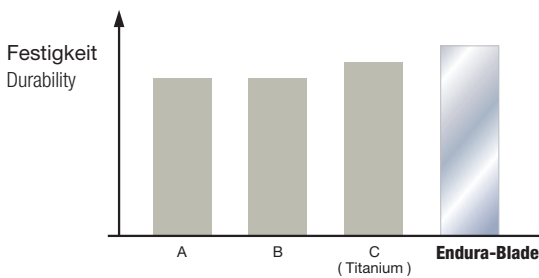

Sharpness



Razar Black Blade

Ideal für präzises Schneiden von Papier, Folie und anderen dünnen Materialien. Extreme scharfe Klinge. Aus Premium-Stahl, japanischer Vergütungs-Technologie und mehrstufigem Schärfen-Prozess wird eine aussergewöhnlich exakte Schnitt-Qualität erzielt.

For precise cutting and fine material slicing, ideal for work with Paper, Film and other Thin Materials. A razor-sharp acute angle blade that integrates premium steel, Japanese-style tempering and multi-step sharpening to produce an exceptionally smooth and fine quality of cut.

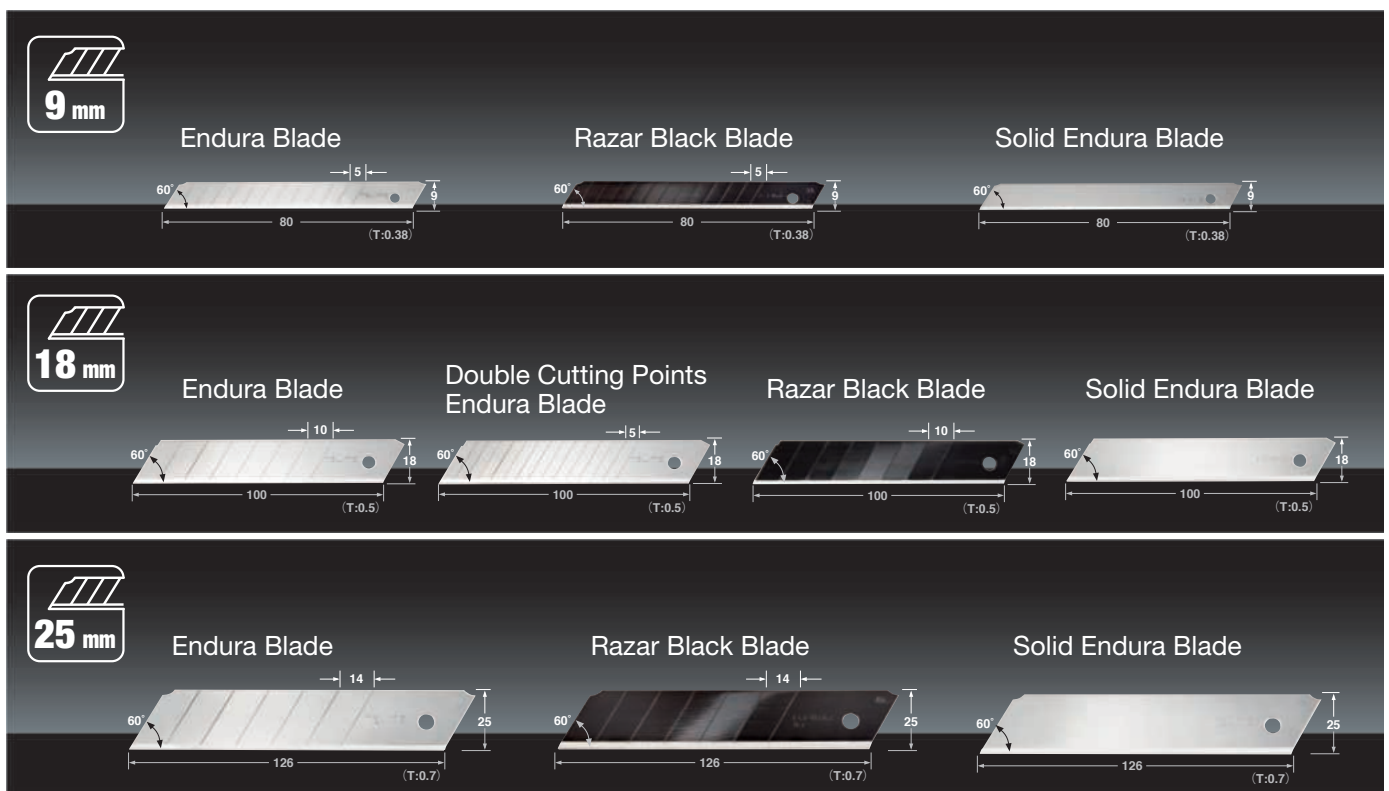
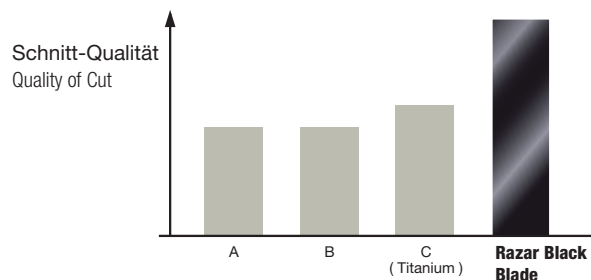

CUTTER KLINGEN

CUTTER KNIFE BLADES

9mm Endura Blade



(T:0.38)

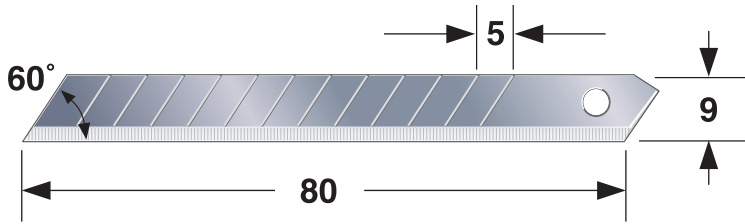

Art.Nr.		CASE ()	MASTER CARTON ()	EAN	Weight (g) (Packaging + Product)
① LB30N/-1	10	10 (100)	120 (1,200)	4975364 051561	22
② LCB30C/Y1	10	10 (100)	120 (1,200)	4975364 014252	25
③ EA-50HC	50	10 (500)	100 (5,000)	4975364 113436	110

9mm Razar Black Blade



(T:0.38)

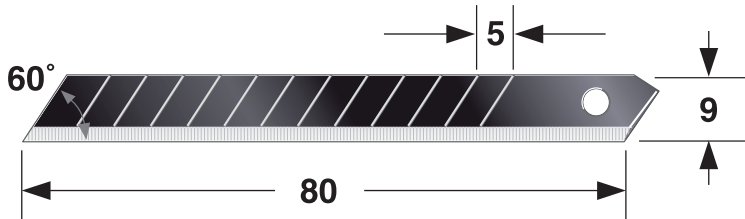

Art.Nr.		CASE ()	MASTER CARTON ()	EAN	Weight (g) (Packaging + Product)
① LCB30RBC/K1	10	10 (100)	120 (1,200)	4975364 111050	25
② RBA-50HC	50	10 (500)	100 (5,000)	4975364 113450	110

9mm Solid Endura Blade



(T:0.38)

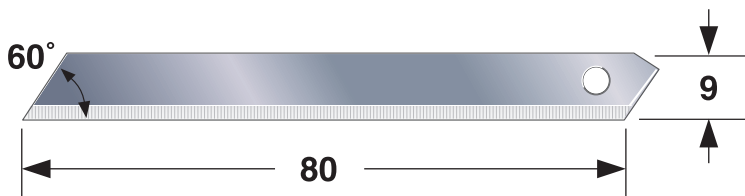

Art.Nr.		CASE ()	MASTER CARTON ()	EAN	Weight (g) (Packaging + Product)
LCB30SC/Y1	10	10 (100)	120 (1,200)	4975364 018984	25

CUTTER KLINGEN

CUTTER KNIFE BLADES

18mm Endura Blade



(T:0.5)

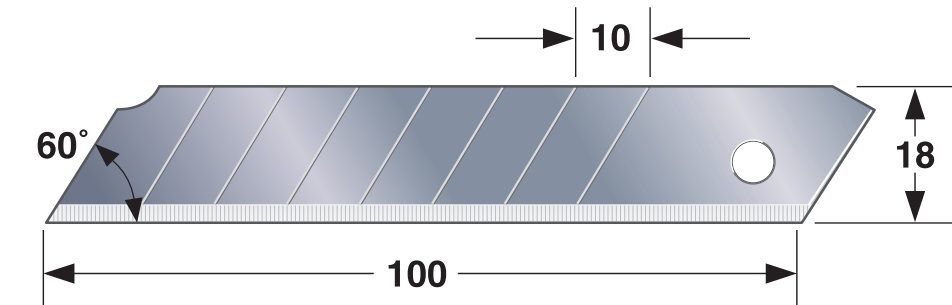

①



②



③



Art.Nr.		CASE ()	MASTER CARTON ()	EAN	Weight (g) (Packaging + Product)
① LB50N/-1	10	10 (100)	120 (1,200)	4975364 021571	62
② LCB50C/Y1	10	10 (100)	120 (1,200)	4975364 014276	80
③ EL-50HC	50	10 (500)	50 (2,500)	4975364 113467	362

18mm Solid Endura Blade



(T:0.5)

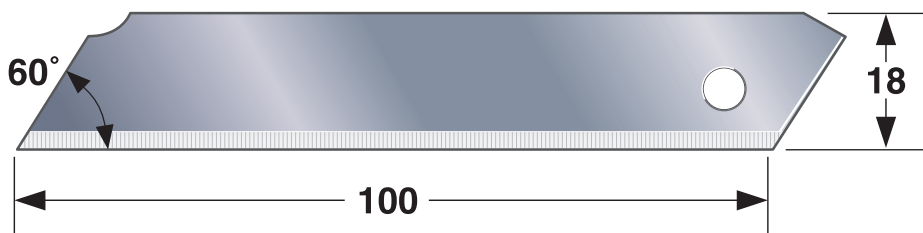

Art.Nr.		CASE ()	MASTER CARTON ()	EAN	Weight (g) (Packaging + Product)
LCB50SN/YE	10	10 (100)	120 (1,200)	4975364 019059	80

18mm Double Segment Endura Blade



(T:0.5)

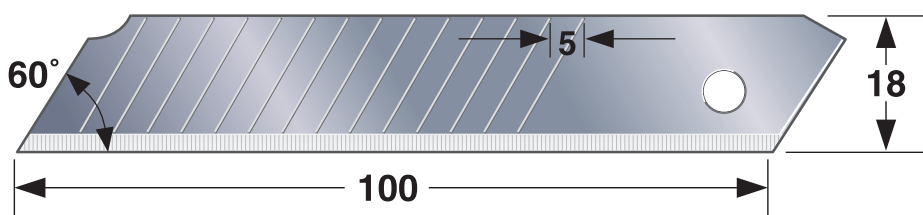

Art.Nr.		CASE ()	MASTER CARTON ()	EAN	Weight (g) (Packaging + Product)
LCB50DC/Y1	10	10 (100)	120 (1,200)	4975364041357	80

CUTTER KLINGEN



CUTTER KNIFE BLADES

18mm Razar Black Blade

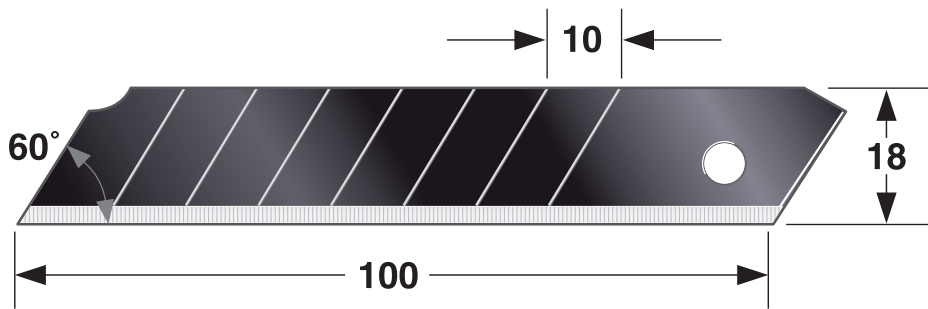

(T:0.5)







Art.Nr.		CASE ()	MASTER CARTON ()	EAN	Weight (g) (Packaging + Product)
① LCB50RBC/K1	10	10 (100)	120 (1,200)	4975364 019042	80
② RBL-50HC	50	10 (500)	50 (2,500)	4975364 113481	362

22m Endura Blade

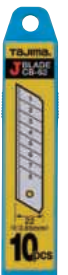
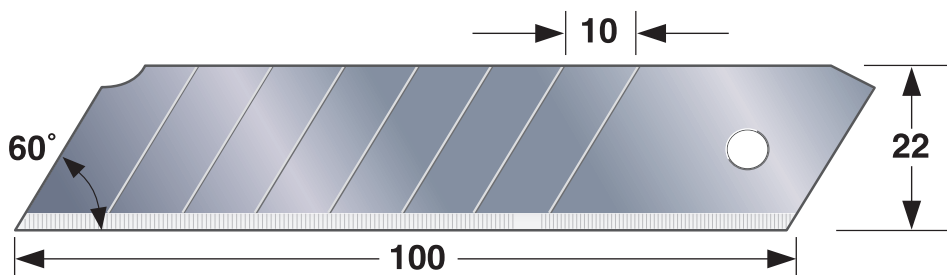

(T:0.65)



Art.Nr.		CASE ()	MASTER CARTON ()	EAN	Weight (g) (Packaging + Product)
CB62H/B1	10	10 (100)	100 (1,000)	4975364 021557	115

CUTTER KLINGEN



CUTTER KNIFE BLADES

25mm Endura Blade

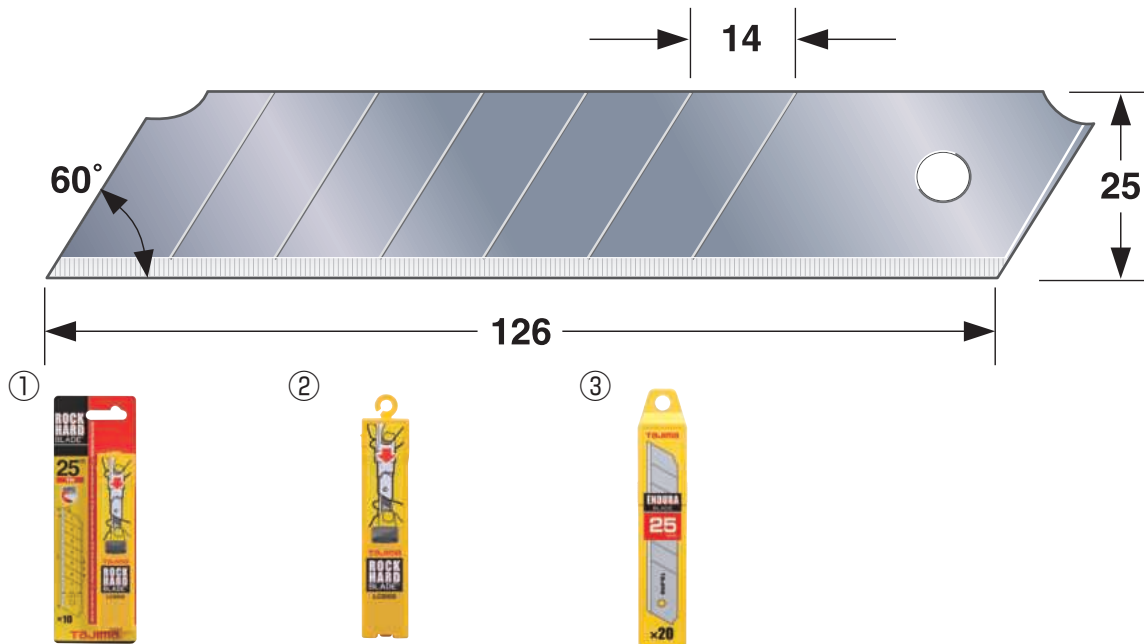

(T:0.7)







Art.Nr.		CASE ()	MASTER CARTON ()	EAN	Weight (g) (Packaging + Product)
① LCB65C/Y1	10	10 (100)	60 (600)	4975364 020888	170
② LCB65N/Y1	10	10 (100)	50 (500)	4975364 018861	170
③ EH-20HC	20	10 (200)	50 (1,000)	4975364 113498	366

25mm Solid Endura Blade

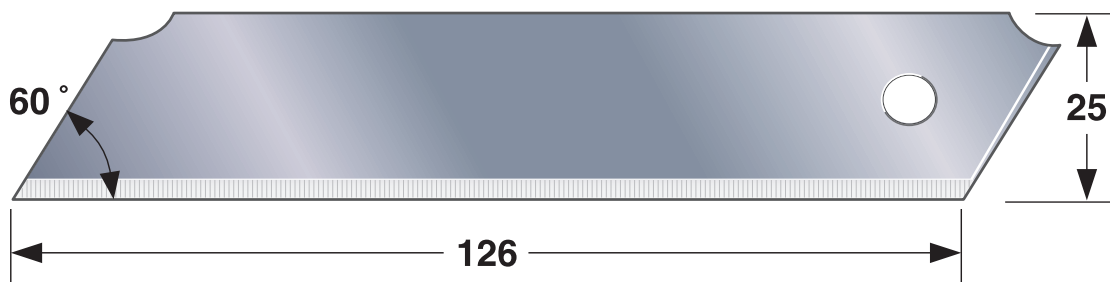

(T:0.7)



Art.Nr.		CASE ()	MASTER CARTON ()	EAN	Weight (g) (Packaging + Product)
LCB65S-10H/Y1	10	10 (100)	50 (500)	4975364 019950	204

CUTTER KLINGEN

CUTTER KNIFE BLADES

25mm Razar Black Blade



(T:0.7)

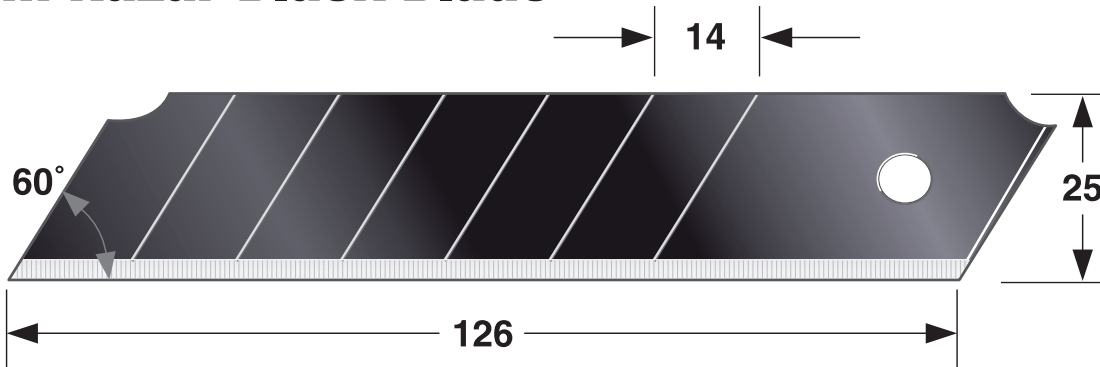

Art.Nr.		CASE ()	MASTER CARTON ()	EAN	Weight (g) (Packaging + Product)
① LCB65RBC/K1	10	10 (100)	60 (600)	4975364 111548	170
② CB65RBC/K1	10	10 (100)	60 (600)	4975364 111982	203
③ RBH-20HC	20	10 (200)	50 (1,000)	4975364 113504	365

Safe Snap



Einfache Entsorgung aller gebrauchten Klingensegmente von 9 - 25 mm.
Verschluss schützt vor versehentlichem Öffnen.
Sichere Verwahrung der gebrauchten Cutterklingen-Segmente.

Cleanly snaps-off blade segments, for all 9 mm - 25 mm cutter blades.
Case lock prevents accidental opening, holds segments for safe disposal.

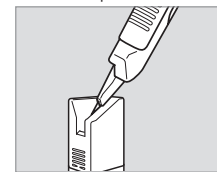

Art.Nr.	Detail	CASE	MASTER CARTON	EAN	Weight (g) (Packaging + Product)
SS001/Y1	BLADE SEGMENT DISPOSAL SYSTEM	24	120	4975364 110732	39

CUTTER KLINGEN

CUTTER KNIFE BLADES

E3 Endura Blade

weight:2g
(T:0.38)

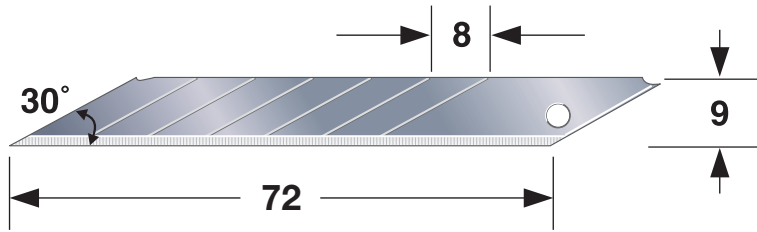

Applicable Models





LC390-EUR



DC395BK-EUR



Art.Nr.		CASE ()	MASTER CARTON ()	EAN	Weight (g) (Packaging + Product)
EE3-10HC	10	10 (100)	240 (2,400)	4975364 113511	28

E3 Razar Black Blade

weight:2g
(T:0.38)

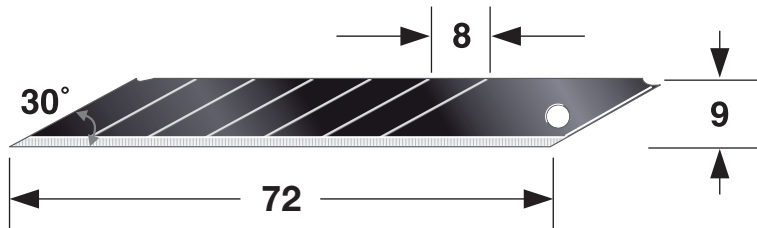

Applicable Models





LC390-EUR



DC395BK-EUR



Art.Nr.		CASE ()	MASTER CARTON ()	EAN	Weight (g) (Packaging + Product)
RBE3-10HC	10	10 (100)	240 (2,400)	4975364 113535	28

CUTTER MESSER

CUTTER KNIVES

DORAFIN



Allzweck-Cutter Messer

A cutter and an all-purpose tool.



Zum Schrauben lösen und festziehen

Driving standard-head screws



Öffnen von Kartons, Rillen von dicker Pappe und Abnehmen von Dosendeckeln.

Opening cartons, scoring thick cardboard and prying off can lids.



Dorafin



DFC560W-EUR



[More info](#)



DFC561W-EUR

[More info](#)



Art.Nr.			BLADE LOCK	CASE	MASTER CARTON	EAN	Weight (g) (Packaging + Product)
DFC560W-EUR	18 mm	1	Auto	10	120	4975364 111890	129
DFC561W-EUR			Dial			4975364 111906	132

CUTTER MESSER

CUTTER KNIVES

Dorafin Quick Back





- CONVEX-SET1**
- G3-Lock 27mm 5 m
 - Dorafin Quick Back
 - Razer Black Blade

Quick Back

Das ORIGINAL TAJIMA QUICK BACK System erlaubt eine sichere Handhabung durch automatischen Rückzug der Klinge.

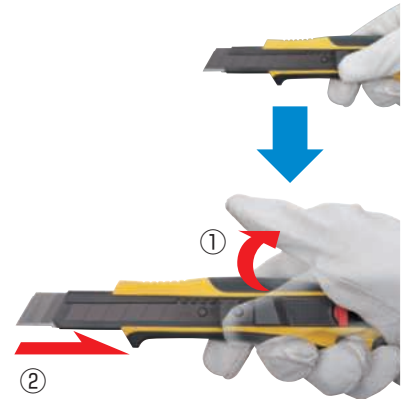
Tajima's self-retracting system is designed to ensure a comfortable grip and optimal performance.



Art.Nr.			BLADE LOCK	CASE	MASTER CARTON	EAN	Weight (g) (Packaging + Product)
DFC579-SY-EUR	18 mm	1	Quick Back	10	120	4975364 113122	142
CONVEX-SET1		Knife : 1 Spare Blade : 10 pcs		6	18	4975364 076168	4,004 (620/pc)

Safety Holster



Applicable Models



Feste Verriegelung
Positive Lock



Einfache Entriegelung
Intuitive, One-Hand Unlock



Einstellbar auf 45 °
Adjustable To 45 °

Art.Nr.	CASE	MASTER CARTON	EAN	Weight (g) (Packaging + Product)
DC50SFC/Y1	10	120	4975364 112002	132

CUTTER MESSER

CUTTER KNIVES

Driver Cutter



Einzigartige Serie von Cuttermessern, mit 1 mm starker Klingenföhrung, extra hart mit multifunktionaler Endspitze.

Unique line of knives that feature ultra hard 1 mm thick tempered blade sleeves with multi-function "driver" tips.



Zum Schrauben lösen und festziehen

Driving standard-head screws



Zum Öffnen von Dosen

Prying off can lids



Zum Öffnen von Kartonagen

Opening cartons, scoring thick cardboard



Driver Cutter



DC360Y-EUR



DC560RB13D12/Y1



DC561RB13D12/Y1





DC560Y-EUR



DC561Y-EUR



Art.Nr.			BLADE LOCK	CASE	MASTER CARTON	EAN	Weight (g) (Packaging + Product)
DC360Y-EUR	9 mm	1	Auto	10	120	4975364 113412	48
DC560Y-EUR	18 mm	3	Auto	10	120	4975364 019929	134
DC561Y-EUR			Dial			4975364 019936	135
DC560RB13D12/Y1			Knife:3	Auto	12	48	4975364 110107
DC561RB13D12/Y1	Spare blade:10	Dial	4975364 110114	2,464 (182/pc)			

CUTTER MESSER

CUTTER KNIVES

Safety Holster



Applicable Models



Feste Verriegelung
Positive Lock



Einfache Entriegelung
Intuitive, One-Hand Unlock



Einstellbar auf 45 °
Adjustable To 45 °

05

Art.Nr.	CASE	MASTER CARTON	EAN	Weight (g) (Packaging + Product)
DC50SFC/Y1	10	120	4975364 112002	132

CUTTER MESSER

CUTTER KNIVES

ALUMINIST®



AUSBALANCIERTE SCHNEIDKRAFT

Die perfekte Zentrierung der Kraft auf die Klinge optimiert die Präzision beim Schneiden.

CENTER-BALANCED CUTTING FORCE

Cutting force balanced on the center of the blade provides superior cutting precision.

SPEZIALGRIFF ALUMINIUMGUSS



Der Griff aus Aluminium-Druckguss ist ergonomisch perfektioniert. Robuste Klingenföhrung aus rostfreiem Edelstahl.

DIE-CAST ALUMINUM HANDLE

Ergonomically-designed die-cast aluminum handle with a heavy-gauge stainless steel blade guide provides safe and dependable performance.

ALUMINIST®



Art.Nr.			BLADE LOCK	CASE	MASTER CARTON	EAN	Weight (g) (Packaging + Product)
AC500S-EUR	18 mm	3	Auto	10	60	4975364 017345	178
AC501S-EUR			Dial			4975364 017383	181
AC700S-EUR	25 mm		Auto			4975364 017352	276
AC701S-EUR			Dial			4975364 017390	277

CUTTER MESSER

CUTTER KNIVES

05

Rock Hard Fin



Die verlängerte Klingenföhrung verstärkt den Klingenaustritt und verhindert vorzeitiges Abbrechen.

Extended blade sleeve supports the edge of blade and it prevents blade breakage.



1,0 mm starke und gehärtete Klingenföhrung mit Finne

1.0 mm thick tempered blade sleeve with fin end

Rock Hard Fin



DFC670-SW-EUR



More info



DFC671-SW-EUR

More info



Art.Nr.			BLADE LOCK	CASE	MASTER CARTON	EAN	Weight (g) (Packaging + Product)
DFC670-SW-EUR	25 mm	2	Auto	6	60	4975364 112514	220
DFC671-SW-EUR			Dial			4975364 112521	219

CUTTER MESSER

CUTTER KNIVES

Top Slider



18 mm

05



Verlängerter Griff für sicheres und effizientes Abmanteln von Kabeln.

Extended grip ensures safe and efficient cable stripping.



Schieber oben auf dem Griff
Top-slider design

Top Slider



18 mm



More info



Art.Nr.			BLADE LOCK	CASE	MASTER CARTON	EAN	Weight (g) (Packaging + Product)
DKC-L590W-EUR	18 mm	1	Auto	10	60	4975364 111913	147

CUTTER MESSER

CUTTER KNIVES

Magazine



05



RUTSCHFESTER GRIFF

in Leichtbauweise, Lademagazin zum automatischen Nachladen der Klinsen.

LIGHTWEIGHT DESIGN



Automatic blade feed, removable magazine and non-slip elastomer grips in a lighter handle design.

Magazine



Magazin-Cutter zum automatischen Nachladen der 18 mm Klinsen. Magazin für 6 Klinsen zum schnellen Nachladen.

Non-slip elastomer grip 18 mm / 3/4 inch cutter holds 6 blades, one blade in the sleeve and 5 blades in the quick-reload magazine.

Art.Nr.			BLADE LOCK	CASE	MASTER CARTON	EAN	Weight (g) (Packaging + Product)
LCM500BK-EUR	18 mm	3	Auto	10	60	4975364 018441	162

CUTTER MESSER

CUTTER KNIVES

GRI®



Robuste Klingenföhrung
Strong blade sleeve

COMFORT CUTTERGRIFF

Der komfortable ELASTOMER Griff ist mit Mehr-Komponententechnik ergonomisch perfektioniert.

COMFORT GRIP KNIVES

Elastomer grip is ribbed for comfort and sure-grip performance.

Gri®



LC560Y-EUR



LC561Y-EUR





LC660Y-EUR



LC661Y-EUR



Art.Nr.			BLADE LOCK	CASE	MASTER CARTON	EAN	Weight (g) (Packaging + Product)
LC560Y-EUR	18 mm	1	Auto	10	120	4975364 113191	116
LC561Y-EUR			Dial			4975364 113214	117
LC660Y-EUR	25 mm		Auto	10	60	4975364 113139	187
LC661Y-EUR			Dial			4975364 113153	188

CUTTER MESSER

CUTTER KNIVES

DURA



Elastomer-Griff 25 mm Cutter mit ultraharter gehärteter Klingenföhrung.

Elastomer-grip 25 mm/1 inch knife with an ultra-hard tempered blade sleeve.



Zur Sicherung an einem Seil.
Tether to a lanyard.

05

Dura



DC660W-EUR

[More info](#)



DC661W-EUR

[More info](#)



Art.Nr.			BLADE LOCK	CASE	MASTER CARTON	EAN	Weight (g) (Packaging + Product)
DC660W-EUR	25 mm	1	Auto	10	60	4975364 111920	180
DC661W-EUR			Dial			4975364 111937	181

CUTTER MESSER

CUTTER KNIVES

Strong-J



Verwenden Sie beide Hände zum Arbeiten, um die grösstmögliche Kraftübertragung zu erreichen.

Use 2 hands to operate while putting all of your strength into cutting process.

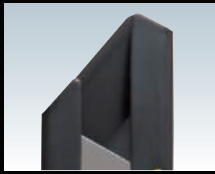

Strong-J Grip/Strong-J Long

Gehärtete Klingenföhrung, bis zu 3,5-mal stärker als Standard-Klingenföhrung

Hardened holder, 3.5 times stronger (in-house comparison)

Strong-J Grip



Praktische GröÙe für die Verwendung mit beiden Händen und für die Werkzeugtasche.

Convenient size to use with both hands and to fit tool pouch.



More info



Art.Nr.			BLADE LOCK	CASE	MASTER CARTON	EAN	Weight (g) (Packaging + Product)
DC690-Y1-10	22 mm	10	Auto	6	24	4975364 112507	2,934 (449/pc)

CUTTER MESSER

CUTTER KNIVES

Strong-J Long



Langer Griff von 180 mm für erhöhte Schnittgeschwindigkeit und Leistung.

Long grip of about 180 mm for enhanced cutting speed and power.

05

Art.Nr.			BLADE LOCK	CASE	MASTER CARTON	EAN	Weight (g) (Packaging + Product)
DC680-Y1-10	22 mm	10	Auto	6	24	4975364 112736	1,900 (267/pc)

Strong-J Standard



Gehärteter Haken bequem zu schneiden, zu stoßen und zu hebeln

Hardened hook convenient to cut, poke and pry



Palm-Fit-Griff, der sich Ihrer Hand anpasst

Palm fit grip that fits with your hand

Art.Nr.			BLADE LOCK	CASE	MASTER CARTON	EAN	Weight (g) (Packaging + Product)
DC610-Y1-10	22 mm	10	Auto	6	24	4975364 112729	1,720 (233/pc)

CUTTER MESSER

CUTTER KNIVES

Standard Cutter



05



LC CLASSIC



Kompakter 9 mm Cutter mit Auto Blade Lock, 2 Klingen im Griffmagazin.

Slim handle 9 mm / Slide Blade Lock knife with in-handle blade storage and 3 Endura blades.





LC303Y-EUR



LC303B-EUR



Art.Nr.			BLADE LOCK	CASE	MASTER CARTON	EAN	Weight (g) (Packaging + Product)
LC303Y-EUR	9 mm	3	Auto	10	120	4975364 113306	43
LC303B-EUR						4975364 113313	

CUTTER MESSER

CUTTER KNIVES

LC Classic



LC500Y-EUR





500C40/A1



LC501Y-EUR



501A40/A1

Art.Nr.			BLADE LOCK	CASE	MASTER CARTON	EAN	Weight (g) (Packaging + Product)
LC500Y-EUR	18 mm	3	Auto	10	120	4975364 112972	102
LC500B-EUR				10	120	4975364 112989	102
500C40/A1				40	120 (3 SETS)	4975364 021380	3,420 (79/pc)
LC501Y-EUR			Dial	10	120	4975364 113016	105
LC501B-EUR				10	120	4975364 113009	105
501A40/A1				40	120 (3 SETS)	4975364 021465	3,500 (81/pc)

LC Classic

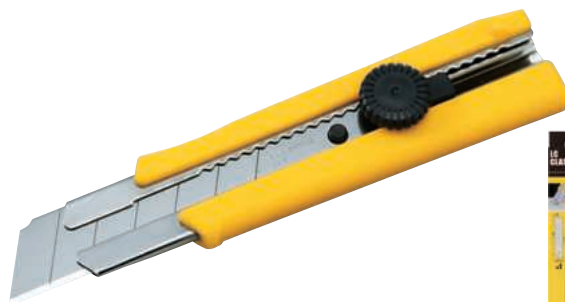

Hochleistungscutter 25 mm mit Elastomer-Griff, ausgestattet mit ENDURA-Klinge, Klingenföhrung aus rostfreiem Edelstahl, Dial Blade Lock.

Extra heavy duty 25 mm / Dial Blade Lock knife with a thick elastomer grip.

Art.Nr.			BLADE LOCK	CASE	MASTER CARTON	EAN	Weight (g) (Packaging + Product)
LC650Y-EUR	25 mm	1	Dial	10	120	4975364 113054	150

CUTTER MESSER

CUTTER KNIVES

LC Classic PRO



LC520Y-EUR



520H40/A1



LC521Y-EUR





521H40/A1TAG



LC620Y-EUR



Art.Nr.			BLADE LOCK	CASE	MASTER CARTON	EAN	Weight (g) (Packaging + Product)
LC520Y-EUR	18 mm	3	Auto	10	120	4975364 113030	105
520H40/A1				40	120 (3 SETS)	4975364 019080	3,560 (83/pc)
LC521Y-EUR			Dial	10	120	4975364 113047	110
521H40/A1TAG				40	120 (3 SETS)	4975364 019097	3,720 (87/pc)
LC620Y-EUR	22mm		Auto	10	120	4975364 112019	130

CUTTER MESSER

CUTTER KNIVES

Precision Craft Basic





9 mm Cutter in 3 Farben, 60 Stück im Display.

Multi-purpose 9 mm / Slide Blade Lock knives equipped with Endura blades, in a 3-color 60 pc. displayer.



305D60/A1

Art.Nr.			BLADE LOCK	CASE	MASTER CARTON	EAN	Weight (g) (Packaging + Product)
305D60/A1	9 mm	1	Auto	60	240 (4 SETS)	4975364 021212	900 (11/pc)

LCM CLASSIC



Edelstahl-Cutter 9 mm extrafein, mit Auto Blade Lock.

Sleek and lightweight stainless steel 9 mm / Slide Blade Lock knife with 3 Endura blades.



Art.Nr.			BLADE LOCK	CASE	MASTER CARTON	EAN	Weight (g) (Packaging + Product)
LC301-EUR	9 mm	3	Auto	10	120	4975364 113276	37

CUTTER MESSER

CUTTER KNIVES

Extra Specialty Cutter Knives

05



E3 DORA

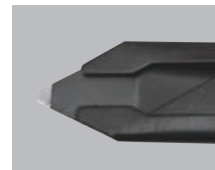

Gehärtete Klingenführung mit vielseitig nutzbarer Micro-Schraubendreher-Funktion.

Tempered blade sleeve with a multifunction "micro-driver" tip.



More info



Art.Nr.			BLADE LOCK	CASE	MASTER CARTON	EAN	Weight (g) (Packaging + Product)
DC395BK-EUR	9 mm	1	Auto	10	120	4975364 113429	39

CUTTER MESSER

CUTTER KNIVES



E3

Für Arbeiten an engen Stellen (Electronic, Computer...)

For cutting and scoring in tight spaces.



05

Art.Nr.			BLADE LOCK	CASE	MASTER CARTON	EAN	Weight (g) (Packaging + Product)
LC390-EUR	9 mm	3	Auto	10	120	4975364 113405	37

WECHSELKLINGEN

UTILITY KNIFE BLADES

V-Rex

Rasiermesserscharfe Klinge mit besonders spitzem Schnittwinkel.

A razor-sharp acute angle blade















06

V-Rex II



Premium gehärtete Klingen mit ultrascharfen Schneidkanten, optimiert für Trockenbau und für jegliche Schneidearbeiten geeignet.

Premium tempered steel blades with razor-sharp cutting edges, optimized for drywall and other heavy-duty cutting and scoring tasks.









Art.Nr.0		BLADE TYPE	Corresponding Knives	CASE	MASTER CARTON	EAN	Weight (g) (Packaging + Product)
VRB2-10B/Y1	10	V-REX II	VR101D / R1 VR102D / B1 VR103D / S1	 10  100	 120  1200	4975364 019578	56
VRB2-50B/Y1	50			 10  500	 40  2000	4975364 019530	258
VRB2-100B/Y1	100			 10  1000	 40  4000	4975364 019547	448

Deep Hook



Erstklassige Hakenklingen, speziell für anspruchsvolle Anwendungen bei starrem Dachmaterial und Bodenbelag entwickelt.

Premium-grade deep hook blades designed to prevent slip-off when cutting rigid roofing or flooring material.

Art.Nr.		BLADE TYPE	Corresponding Knives	CASE	MASTER CARTON	EAN	Weight (g) (Packaging + Product)
HKB-10B/Y1	10	DEEP HOOK	VR101D / R1 VR102D / B1 VR103D / S1	 10  100	 120  1200	4975364 019585	49
HKB-50B/ Y1USA	50			 10  500	 40  2000	049296019556 (UPC)	227

V-REX MESSER

UTILITY KNIVES



V-Rex FIXED TYPE



- VR-101 mit feststehender Klinge. VR-102 mit einstellbarer Klinge
- Große Flügelschraube für Klinsenwechsel, Klinsenmagazin im Gehäuse mit Haltemagnet

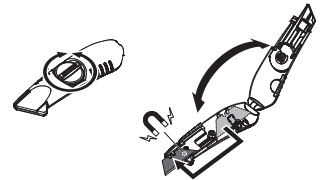

- Rugged one-piece fixed blade utility knife
- Open easily with a large thumb-screw

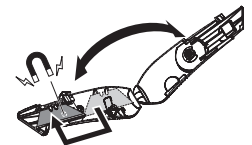

Art.Nr.			BLADE LOCK	CASE	MASTER CARTON	EAN	Weight (g) (Packaging + Product)
VR101R-EUR	19 mm	3	FIXED TYPE	10	60	4975364 113238	178

V-Rex RETRACTABLE TYPE



Art.Nr.			BLADE LOCK	CASE	MASTER CARTON	EAN	Weight (g) (Packaging + Product)
VR102B-EUR	19 mm	3	RETRACTABLE TYPE	10	60	4975364 113368	236



V-Rex Safety Knife

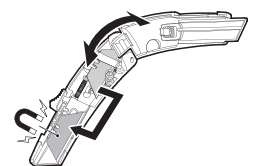

- VR-103 mit automatischem Klinsenrückzug
- Praktischer Verriegelungsmechanismus

- Self-retracting utility knife
- Conveniently located slide lock mechanism



Art.Nr.			BLADE LOCK	CASE	MASTER CARTON	EAN	Weight (g) (Packaging + Product)
VR103S-EUR	19 mm	3	Quick Back	10	60	4975364 113375	197

SICHERHEITSMESSER

SAFETY KNIFE

Safety Knife

Bei Beendigung des Schneidvorgangs fährt die Klinge automatisch zurück.

Auto-retract blade when it leaves the cutting material.

Einfache Anwendung 3 Stufen

The simple usage 3 steps



① Schieben Sie die Klinge heraus und beginnen Sie mit dem Schneidvorgang.

① Slide out the blade and start cutting.



② Beim Schneiden nicht den Daumen auf dem Schieber halten.

② While cutting, do not hold thumb on slider.



③ Bei Beendigung des Schneidvorgangs fährt die Klinge automatisch zurück.

③ Knife automatically retracts the blade as soon as the blade is released from your cutting material.

Safety Knife

Sicherheitsmesser mit automatischem Klingeneinzug. Schieberverriegelung verhindert, dass die Klinge unerwartet heraussteht.

Safety design with auto blade retraction. Slider lock prevents blade from sticking out unexpectedly.

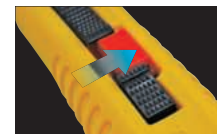



Art.Nr.		BLADE LOCK	CASE	MASTER CARTON	EAN	Weight (g) (Packaging + Product)
LC959X/Y1	1	Quick Back	10	120	4975364 112064	110

Safety Knife Blade

Beide Klingenseiten einsetzbar. Durchgehende Klinge für sichere Verwendung.

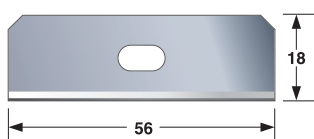
Both sides of the blade can be used. Blade without notch for safer use.



Art.Nr.		CASE	MASTER CARTON	EAN	Weight (g) (Packaging + Product)
CB93H/Y1	10	20	240	4975364 112071	50

Cutter Guide

Professionelle Schneidhilfe mit Präzisionsskalierung. Leichter Aluminium-Hohlkörper mit Fingerschutzblende und Edelstahlschiene als Ziehkante für Cutterklingen.

Professional grade cutter guide with a precise metric scale. Hollow-core aluminum design with ribbed finger hold and stainless steel guide.

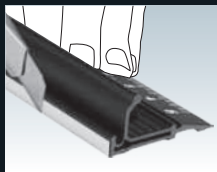

Die Edelstahlschiene schützt Finger
Stainless steel guides



Antirutschsockel
Non-slip base



09

Cutter Guide Slim

300 / 600 / 1000



CTGSL300/K1



CTGSL600/K1



CTGSL1000/K1

Die 18,5 mm hohe Sicherheitskante gewährleistet einen sauberen Schnitt und schützt die Hände sicher. Die Edelstahlschiene schützt Finger und Werkzeug gleichermaßen.

18.5 mm raised finger guard for safety and positive control. Stainless steel guides won't nick or scratch from cutter blades.

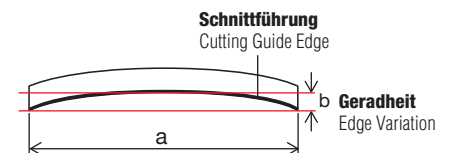

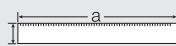
Art.Nr.			b	CASE	MASTER CARTON	EAN	Weight (g) (Packaging + Product)
CTGSL300/K1	300 mm	310 mm (±0.2 mm) × 40 mm	Edge Variation	10	80	4975364 163974	100
CTGSL600/K1	600 mm	610 mm (±0.28 mm) × 40 mm			40	4975364 163981	220
CTGSL1000/K1	1000 mm	1010 mm (±0.4 mm) × 40 mm			20	4975364 165008	320

SPEZIAL WERKZEUGE

SPECIALTY TOOLS

Clipper

Premium Klinge mit Fluoro-Beschichtung

Premium Fluoro-coat Blade



Antihafbeschichtung
Non stick



gezahnten Klingen
Serrated blade edges
(CPG175B/Y1)



09

Clipper 160 / 210



CLP160B/Y1



Präzisionsscheren für exakte Schnitte. Das Premium FLUORO-Coating verhindert das Anhaften von Materialien an der Klinge. Komfortable Bedienung durch angenehme Griffergonomie.

Precision scissors for precise cuts. Premium Fluoro-Coat Blade Coating prevents sticking to material your cutting. Nice cutting action, feels great in the hand.



More info



CLP210B/Y1



Art.Nr.		FEATURES	CASE	MASTER CARTON	EAN	Weight (g) (Packaging + Product)
CLP160B/Y1	160 mm	Premium Fluoro-Coat Blade	10	100	4675364 112033	55
CLP210B/Y1	210 mm				4975364 112040	120

Clipper 175 Garden Scissors



Die gezahnten Klingen schneiden verbessern die Kontrolle beim Schneiden spürbar. Das Premium FLUORO-Coating verhindert das Anhaften von Materialien an der Klinge.

Enhance control when pruning. Premium Fluoro-Coat Blade Coating prevents sticking to material your cutting.

09

Art.Nr.		FEATURES	CASE	MASTER CARTON	EAN	Weight (g) (Packaging + Product)
CPG175B/Y1	175 mm	Premium Fluoro-Coat Blade	10	100	4975364 112057	80

SPEZIAL WERKZEUGE

SPECIALTY TOOLS

For electrical and utility work



09

Foldable Blade Multi-purpose Knife

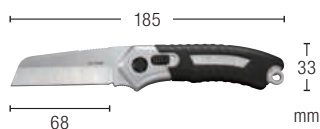

- Kompakt, einfach in der Handhabung
- Sicherheitsverriegelung sorgt dafür, dass die Klinge eingeklappt bleibt

- Compact size — easy to use, portable
- Safety lock ensures blade stays retracted



Mit Sicherheitsverriegelung durch Schieber
Sicherheitsverriegelung im aufgeklappten und eingeklappten Zustand

Slide safety lock mechanism
Ensures blade stays retracted, or does not close while in use



Halteöse ($\varnothing 5.2$ mm)
Mehrere Kabel einziehbar

Ring sleeve (small)Holding eye ($\varnothing 5.2$ mm)

Insert up to 4 cords easily
(Also accommodates safety rope)

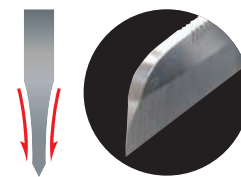

Klinge mit Hohlschliff
Hollow-shaped blade

Art.Nr.	CASE	MASTER CARTON	EAN	Weight (g) (Packaging + Product)
DK-FKSD-EUR	6	36	4975364 267894	145

SPEZIAL WERKZEUGE

SPECIALTY TOOLS

Mini Knife for Cables



Blade protector

- Kompakt, liegt gut in der Hand
- 43mm Klinge, für Kabelarbeiten
- Hochwertiges Oberflächen-Finish
- Rutschfester Griff

- Just fit to a hand & Compact Body Size
- "43mm" Mini-Blade, Best for stripping off cable coating
- Fine Finish Surface
- Non-slip Elastomer Grip with Globe wearing



Gehärtete Klinge

Striking End-grip blade



Die neue Form der Top-Klinge

The original new shape of Top-blade

Art.Nr.	CASE	MASTER CARTON	EAN	Weight (g) (Packaging + Product)
DK-TNMN-EUR	6	36	4975364 267887	105

Holster for Mini Knife for Cables



Wearable Adjustable Belt Sizes

Up to 53 mm wide
Up to 3.0 mm thick



Mit Gürtelhalter

Includes Safety Belt Holder — attach while wearing belt

Art.Nr.	CASE	MASTER CARTON	EAN	Weight (g) (Packaging + Product)
DK-MSFHS-EUR	6	36	4975364 267900	135

Cable Mate Knife



Klingenschutz

Blade protector

Multifunktions-Messer. Aus einem Stück hergestellte Solid-Core Edelstahl-Klinge. Geeignet zum Schneiden, Abisolieren, Aufrauen, Schaben und Stemmen.

Multi-purpose electrician's knife. Solid-Core blade is formed from one continuous piece of stainless steel and can be used with a hammer for chisel-like tasks.



Grosser Schlagbereich

Large striking area

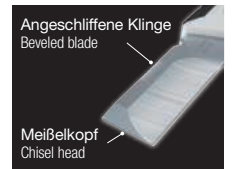

Angeschliffene Klinge

Beveled blade

Meißelkopf

Chisel head

Art.Nr.	CASE	MASTER CARTON	EAN	Weight (g) (Packaging + Product)
DKTN80X/W1	10	80	4975364 164018	167

SPEZIAL WERKZEUGE

SPECIALTY TOOLS

Varix Scissors

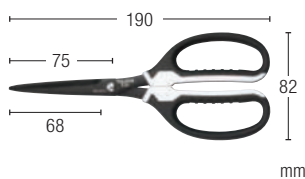

Cutting ability

Tape
Thin wires
PP-Band

- Schere für viele Anwendungen und Materialien
- Lange Schneiden, auch für breites Klebeband (50 mm) in einem Schnitt

- Scissors for electrical and utility work • Safety lock ensures blade stays retracted
- Long blades, cut wide tape (50 mm) clean in one snip



Haltekerben am Beginn der Schneide für Drähte und runde Materialien

Serrations at base cut thin wires without slipping



Silikonbeschichtete Klinge widersteht Kleberückständen

Silicone-coated blade resists glue build-up



Mit passendem Köcher zum Schutz

Blade case protects blades while stored

Art.Nr.	CASE	MASTER CARTON	EAN	Weight (g) (Packaging + Product)
DK-BT70-EUR	6	36	4975364 267917	110

Varix Tradesman Shears



Cutting ability

Glass wool
Rock wool
Rubber, sound-insulating sheet
PP-Band
Protective panel
Wire mesh

- Lange Schneiden für große Materialien
- Perfekt geeignet zum Schneiden von Isoliermaterial

- New, easy-to-use shape cuts long lengths
- Perfect also for carpenters working with insulation material



Einhandbedienung durch Feder

Spring mechanism allows use with one hand

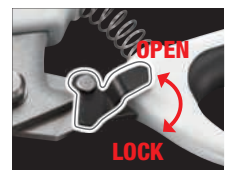

Hebel zur Entriegelung mit einer Hand

One-touch lock



Mit passendem Köcher zum Schutz

Blade case protects blades while stored

Art.Nr.	CASE	MASTER CARTON	EAN	Weight (g) (Packaging + Product)
DK-BD120-EUR	4	24	4975364 267924	385

SPEZIAL WERKZEUGE

SPECIALTY TOOLS

Top slider



Verlängerter Griff für sicheres und effizientes Abmanteln von Kabeln.

Extended grip ensures safe and efficient cable stripping.



Schieber oben auf dem Griff

Top-slider design



Art.Nr.			BLADE LOCK	CASE	MASTER CARTON	EAN	Weight (g) (Packaging + Product)
DKC-L590W-EUR	18 mm	1	Auto	10	60	4975364 111913	147

Multi-purpose Cable Cutter



Mehrzweckscheren. Hartverchromte Klingen schneiden mühelos Kabel und dünne Bleche. Spezielle Kerbung auf der Klingenoberkante für einfaches Entgraten.

Multi-purpose scissors. Hard Chrome Plated Blade cuts cables and sheet metals. Grooves on back of the blade help deburring.

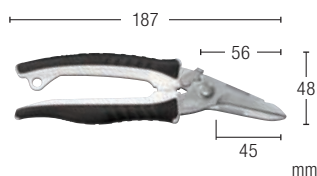
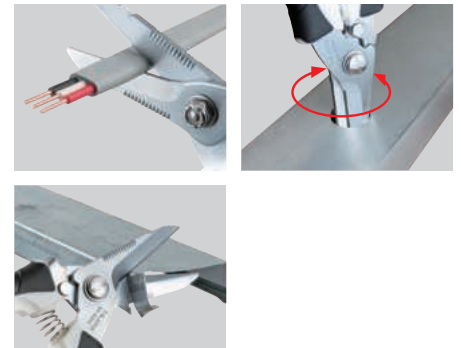

Art.Nr.	CASE	MASTER CARTON	EAN	Weight (g) (Packaging + Product)
DKBB50B/W1	6	36	4975364 162045	167

SCHABER SCRAPERS

Scrape-Rite® P



Sicherheitsschutzkappe bei Nichtgebrauch.

Protective blade cover for your safety.



Durch Umdrehen des Kopfes beidseitige Verwendung.

It can be used identically even when the head is turned over.



Ergonomischer Griff für angenehme Handhabung.

Ergonomic grip for smooth handling.

Austausch der Klinge Blade Replacement

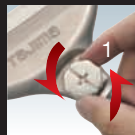

Klingenwechsel ohne Werkzeug, zum Nachspannen Schraubendreher verwenden.

No tools needed. Use a screwdriver only if it needs to be tightened.



Federbelastete Klemmbacken verhindern Klingerverlust. Geschliffene oder stumpfe Seite der Klinge können verwendet werden.

Spring-loaded blade clamp to prevent the blade from sliding off when replacing blades. Both cutting edge and blunt side of the blade can be used.

Klinge / Applicable blade
LCB-50, LCB-50RBC, LCB-50DC, LCB-50SN, CB-62

Scrape-Rite® P Flat Head



Gerader flacher Kopf für ebene Flächen. Schaber kann beidseitig verwendet werden, auch wenn der Kopf umgedreht wird.

The flat head which is vertical to the handle works best for evening out surfaces. It can be used identically even when the head is turned over.



More info



Art.Nr.				BLADE	CASE	MASTER CARTON	EAN	Weight (g) (Packaging + Product)
PSCL300F/W1	305 mm	18 mm	3	ENDURA-BLADE	6	24	4975364 058034	400

Scrape-Rite® P Angled Head



PSCL300A/W1



PSCL500A/W1

Der 20-Grad-Winkelkopf mit 20° Neigung ist ideal zum Entfernen von Materialien wie Tapeten.

Federbelastete Klemmbacken verhindern Klingerverlust.

Wahl der idealen Griff-Länge von jeweiliger Anwendung abhängig.

The 20° angled head against the handle works best for scraping off materials like wallpaper.

Blade stopper prevents the blade from sliding down.

Choose a right handle length based on your usage and workflow.

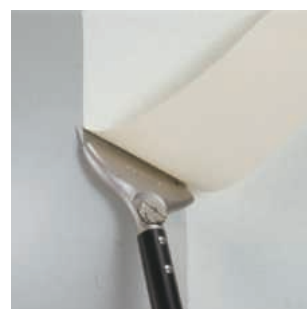

10

More info



Art.Nr.				BLADE	CASE	MASTER CARTON	EAN	Weight (g) (Packaging + Product)
PSCL300A/W1	330 mm	18 mm	3	ENDURA-BLADE	6	24	4975364 058010	400
PSCL500A/W1	520 mm					12	4975364 058027	550

SCHABER

SCRAPERS

Scrape-Rite® P

Solid Core Optimal Blade



Die längere Klinge verhindert, dass abgeschabtes Material den Schaberkopf beschädigt.

The longer blade prevents scraped debris from hitting the scraper head.



Gekrüpfter Kopf schützt Hände vor Verletzungen.

The head is set at a lower level than the handle when using so it avoids your hands getting hit by debris.



Ergonomischer Griff für angenehme Handhabung.

Ergonomic grip for smooth handling.

10

Scrape-Rite® P

Solid Core Flexible



Rund geformte Kanten der Klinge verhindern eine Beschädigung des Materials.

Round shaped edges of the blade prevent its material from being damaged.



Flexible Klinge
Einstellbare flexible Klinge

Flexible Blade
Based on your usage, please adjust flexure of the blade.



Art.Nr.			CASE	MASTER CARTON	EAN	Weight (g) (Packaging + Product)
PHR250F80/W1	280 mm	80 mm	6	24	4975364 058065	360

Scrape-Rite® P Solid Core Hard



PHR250H80/W1

PHR500H80/W1

Extra starke Klinge zum Schaben von harten Materialien.

Extra thick hard blade for scraping off hard materials.

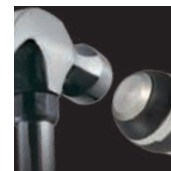



Breiter Schlagkopf für Hammer.

Extra-wide striking head offers a large target area for safer and easier hammering applications.

10



Art.Nr.			CASE	MASTER CARTON	EAN	Weight (g) (Packaging + Product)
PHR250H80/W1	285 mm	80 mm	6	24	4975364 058041	420
PHR500H80/W1	565 mm			12	4975364 058058	610

Replacement Blade

PHR250F80/W1
Replacement blade



PHR- FB80/-1

PHR250H80/W1
PHR500H80/W1
Replacement blade



PHR-HB80/-1



Art.Nr.		CASE	MASTER CARTON	EAN	Weight (g) (Packaging + Product)
PHR-FB80/-1	80 mm	4	36	4975364 058089	50
PHR-HB80/-1				4975364 058072	80

SCHABER SCRAPERS

Scrape-Rite® Solid Core

UNIVERSAL SCHABER Aus einem Stück Edelstahl geschmiedet. Mit Schlagplatte am obersten Ende. Kraft des Schlages wird dadurch direkt auf das Werkstück übertragen. Somit exzellente Werkzeugkontrolle.

Scrape-Rite Solid Core is formed from one continuous piece of premium stainless steel and capped with a wide striking head. Hammer impact to the head is conveyed directly to the blade resulting in faster, more efficient performance and exceptional control.



EXTRAROBUSTE KLINGE

Mit 1,8 mm Klingenstärke, Wärmebehandelt und gehärtet für aussergewöhnliche Ergebnisse.

STRONGER BLADE

Extra-thick 1.8 mm stainless steel blades are heat treated and hardened for superior strength and dependable performance.



AUSERGEWÖHNLICHER GRIP
Ergonomisch perfektionierter Mehr-Komponenten-Griff. Schlag- und abrutschfester Komfort-Griff.

SUPERIOR GRIP

Hardened resin handles are impact-resistant and ergonomically designed to provide exceptional comfort and positive, non-slip control.

GROSSE SCHLAGPLATTE

Die extradicke Schlagplatte ist extrem robust. Grosse Schlagfläche gewährleistet sicheres Arbeiten.

EXTRA-WIDE STRIKING HEAD

Thick stainless steel striking heads are extremely durable and offer a large target area for safer and easier hammering applications.

Scrape-Rite® Solid Core



Klassische Schaberform für das Abschaben von Leim, Kleber, Farbe

Traditionally flared blades for common scraping tasks.

Art.Nr.		CASE	MASTER CARTON	EAN	Weight (g) (Packaging + Product)
SCRC50/Y1	50 mm	12	96	4975364 017970	180
SCRC75/Y1	75 mm			4975364 017987	200

Scrape-Rite® Solid Core Fishtail Blade



Diagonale Schaberform für Arbeiten in beengten Verhältnissen - dort wo Standard-Schaber nicht hinkommen.

Wide fishtail blades for corners and recessed areas that other blades can't reach.



Art.Nr.		CASE	MASTER CARTON	EAN	Weight (g) (Packaging + Product)
SCRN95/Y1	95 mm	12	96	4975364 018007	200

Scrape-Rite® Solid Core Multi-Tool Blade



Schaberform für multifunktionale Anwendungen.

All-in-one blade designed to handle multiple scraping tasks.



Art.Nr.		CASE	MASTER CARTON	EAN	Weight (g) (Packaging + Product)
SCRM75/Y1	75 mm	12	96	4975364 018021	180

Scrape-Rite®

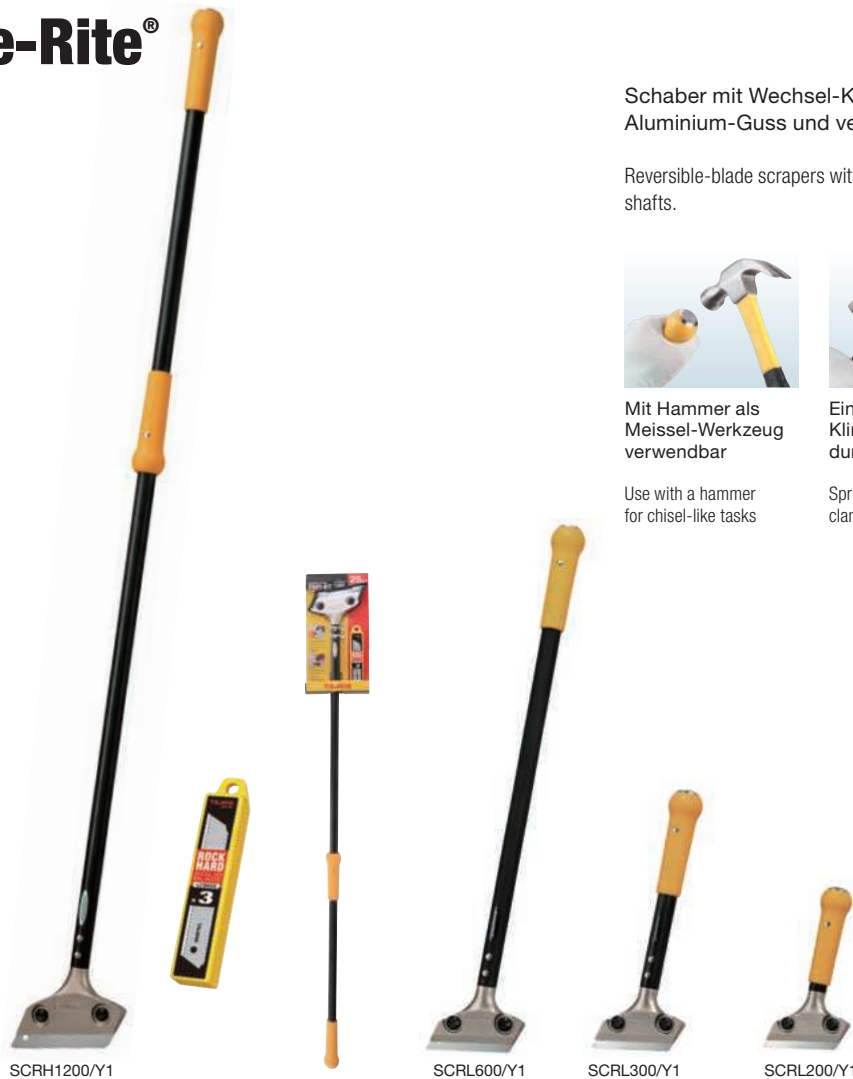

SCRH1200/Y1

SCRL600/Y1

SCRL300/Y1

SCRL200/Y1

Schaber mit Wechsel-Klingen. Schaber-Kopf aus Aluminium-Guss und verstärktem Schaft.

Reversible-blade scrapers with die-cast aluminum heads and reinforced shafts.



Mit Hammer als Meissel-Werkzeug verwendbar

Use with a hammer for chisel-like tasks



Einfacher Klingenwechsel durch Knopfdruck

Spring-loaded blade clamp



Klingen-Schutz
Protective blade guard

Art.Nr.		BLADE	CASE	MASTER CARTON	EAN	Weight (g) (Packaging + Product)
SCRL200/Y1	18 mm	3	4	24	4975364 016126	314
SCRL300/Y1					4975364 016133	460
SCRL600/Y1					4975364 016140	558
SCRH1200/Y1	25 mm	25 mm ENDURA-BLADE		8	4975364 019967	1,220

HANDSÄGEN & SÄGEBLÄTTER

HAND SAWS & BLADES

JAPAN PULL

Japanische Zugsägen - schneller, präziser und kraftsparend

Precision Pull-Stroke Saws That Cut Cleaner, Faster And With Less Effort.

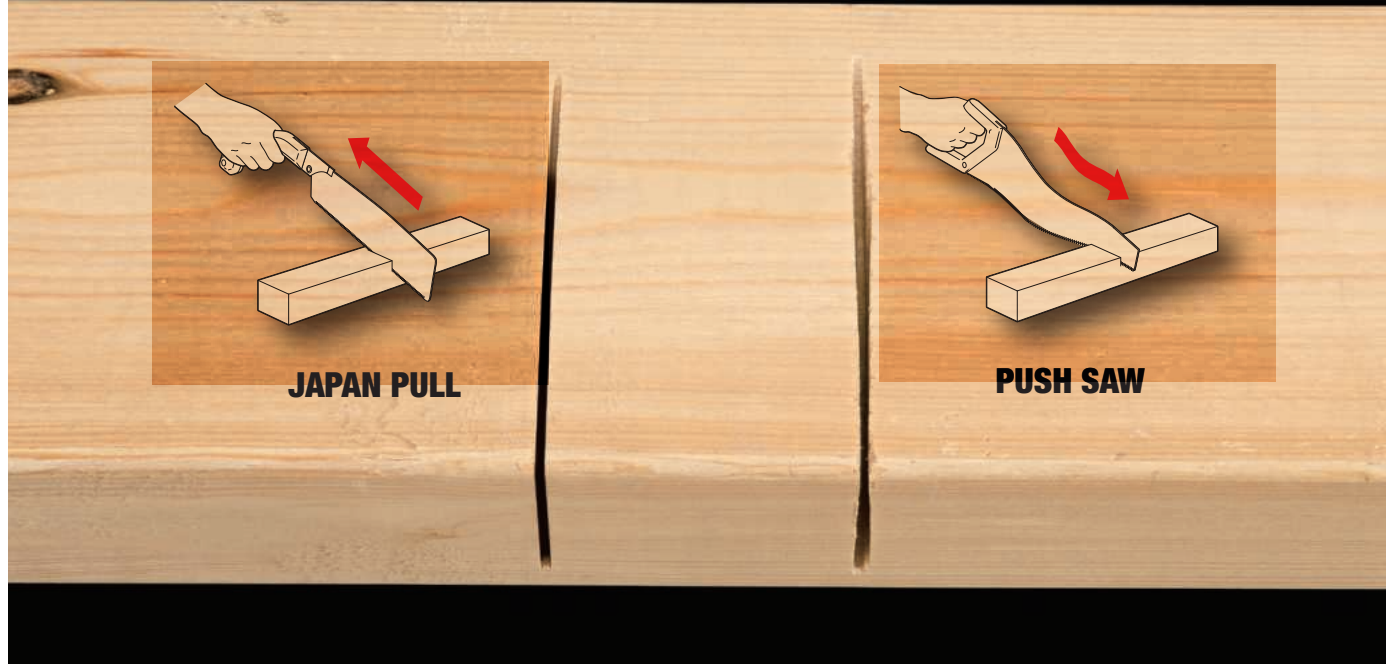

11



Premium Sägeblatt mit FLUORO COAT-Beschichtung und 3fach geschliffener Zahnung. Mit Japanischem Güteverfahren hergestellt.

Japanese tempered SK-95 premium steel blade with triple cutting edge teeth and Fluoro-Coat blade coating.



Premium Sägeblatt aus SK-95 mit 3fach geschliffener Zahnung.

Japanese tempered SK-95 premium steel blade with triple cutting edge teeth.



HANDSÄGEN & SÄGEBLÄTTER

HAND SAWS & BLADES

JAPAN PULL

Blade-Funktionen

Blade Features



Wärmebehandelt und gehärtet für aussergewöhnliche Haltbarkeit und lang anhaltende Schärfe.

Unique steel hardening process that results in blades with exceptional durability and cutting performance.



4x4 Zahnung mit 4 grossen und 4 kleinen Sägezähnen führt zu einer 3fach längeren Standzeit.

Alternating 4 tall, 4 short teeth pattern that results in cutting edge sharpness that lasts 3 times longer.

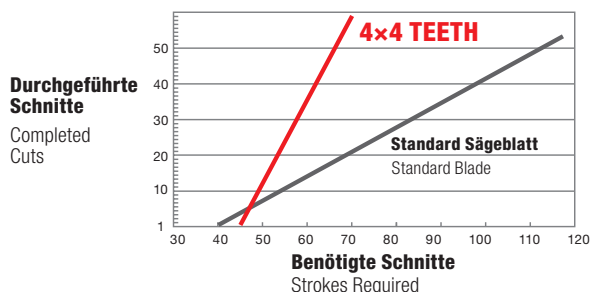

Durch die Schockkühlung des zuvor mit Hochfrequenz erhitzten Stahls wird das Sägeblatt extrem hart und zäh zugleich.

Spot hardening of blade teeth to further enhance the cutting performance while not reducing blade flexibility.



Diese Japansäge ist gut für Längs- und Querschnitte zur Faser geeignet! Schneidet leicht und geradlinig. Eine einzigartige Fluorbeschichtung verhindert Festfressen und das Anhaften von Harz.

This crosscut saw eats through anything, thick or thin. Cuts through well and in a straight line. Unique fluorine coating prevents seizing and adherence of gum.



*Nach 100 Sägezyklen in einem 40 mm starken Baum-Ast
*After cutting through 40 mm thick branches, 100 times.



EXTRA stabiles Sägeblatt für exzellente Führung und Schnittkontrolle.

Extra rigid blade for superior tracking and cutting control.

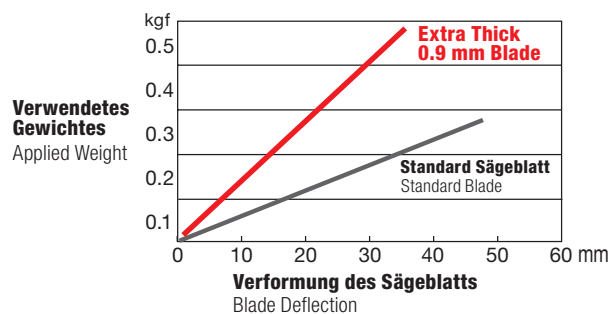

HANDSÄGEN & SÄGEBLÄTTER

HAND SAWS & BLADES

Japan Pull R-Saw

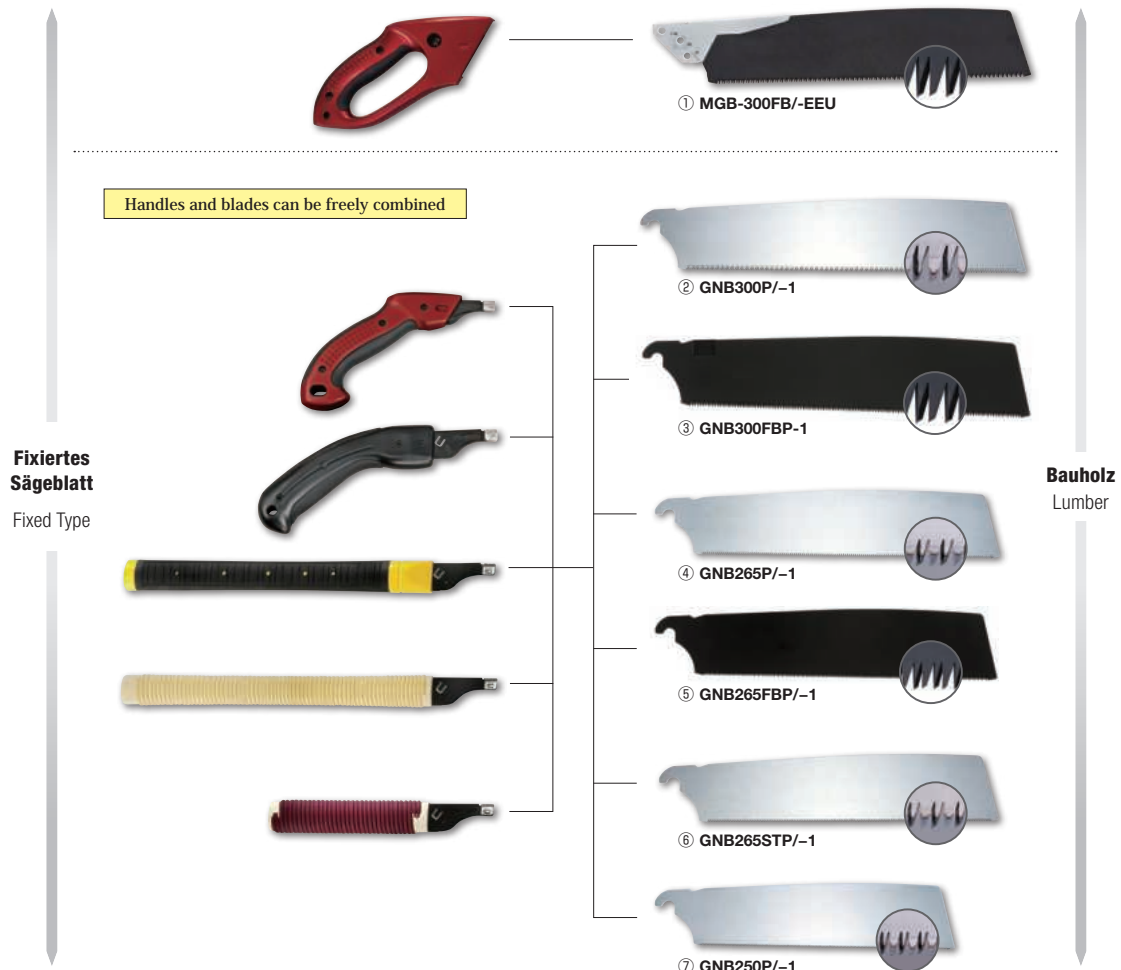

11

		Material-Anwendung Material Suitability Index				
Blade-Funktionen Blade Features						
① MGB-300FB/-EEU	Standard-Schnitt Standard Cut	2.15 mm	13 TPI	0.7 mm (1.15 mm)	— ★ ★★ ★★ ★★ —	
② GNB300P/-1						
③ GNB300FBP-1						
④ GNB265P/-1	Fein-Schnitt Fine Cut	1.75 mm	16 TPI	0.6 mm (0.9 mm)	— ★★ ★★ ★★ ★ —	
⑤ GNB265FBP-1						
⑥ GNB265STP/-1						
⑦ GNB250P/-1	Extra-Fein-Schnitt Extra Fine Cut	1.40 mm	19 TPI	0.5 mm (0.7 mm)	— ★★ ★★ ★ — —	

HANDSÄGEN & SÄGEBLÄTTER

HAND SAWS & BLADES

Magnum



Premium-Zimmermannssäge mit einzigartigem 13 TPI FLUORO COAT Sägeblatt, Komfortabler 2Komponentengriff, Sicherheitshülle schützt das Sägeblatt.

Premium carpenter saw with a 13 TPI Fluoro-Coat blade and an oversize handle with an embedded elastomer grip and a protective blade guard that covers then entire blade.

Art.Nr.					CASE	MASTER CARTON	EAN	Weight (g) (Packaging + Product)
MG300FB/REEU	300 mm	2.15 mm	13 TPI	0.7 mm (1.15 mm)	4	12	4975364 019028	530

Japan Pull ALUMINIST®



Präzisions-Zugsäge mit Schnellwechsel-System ohne Werkzeug in ALUMINIST-Ausführung. Ergonomischer 2Komponentengriff, Sicherheitshülle schützt das Sägeblatt.

Precision pull-stroke saws with Quick-Release blade retainers, die cast aluminum handles with embedded elastomer grips and protective blade guards.

Art.Nr.					CASE	MASTER CARTON	EAN	Weight (g) (Packaging + Product)
JPR265A/R1	265 mm	1.75 mm	16 TPI	0.6 mm (0.9 mm)	6	24	4975364 110329	424
JPR265AFB-R1							4975364 112859	424
JPR300A/R1	300 mm	2.15 mm	13 TPI	0.7 mm (1.15 mm)			4975364 110336	554

Japan Pull



Präzisions-Zugsäge mit Schnellwechsel-System ohne Werkzeug, Ergonomischer abgerundeter 2Komponentengriff.

Precision pull-stroke saws with Quick-Release blade retainers and curved handles with elastomer non-slip grips.

Art.Nr.					CASE	MASTER CARTON	EAN	Weight (g) (Packaging + Product)
JPR265D/K1	265 mm	1.75 mm	16 TPI	0.6 mm (0.9 mm)	6	24 (4 SETS)	4975364 019356	1,620 (204/pc)
JPR300/K1	300 mm	2.15 mm	13 TPI	0.7 mm (1.15 mm)		60	4975364 019363	266

HANDSÄGEN & SÄGEBLÄTTER

HAND SAWS & BLADES

Japan Pull 265 Fluorine Black



Rutschfester Elastomergriff, schonend für die Hand.

Non-slip elastomer grip, soft on hands.

Art.Nr.					CASE	MASTER CARTON	EAN	Weight (g) (Packaging + Product)
JPR265FBR/Y1	265 mm	1.75 mm	16 TPI	0.6 mm (0.9 mm)	6	24	4975364 112538	230

Japan Pull 265 Rubber Grip



Japansäge mit Schnellwechsel-System ohne Werkzeug, in klassischer gerader Ausführung, 2Komponentengriff.

Precision pull-stroke saw with a Quick-Release blade retainer and a traditional straight handle with elastomer grip.

Art.Nr.					CASE	MASTER CARTON	EAN	Weight (g) (Packaging + Product)
JPR265R/Y1	265 mm	1.75 mm	16 TPI	0.6 mm (0.9 mm)	6	24	4975364 019707	230

Japan Pull 265 Classic Grip



Klassische Japansäge mit Schnellwechsel-System ohne Werkzeug, in gerader Ausführung, Rattangriff.

Precision pull-stroke saw with a Quick-Release blade retainer and a traditional straight handle with rattan grip.

Art.Nr.					CASE	MASTER CARTON	EAN	Weight (g) (Packaging + Product)
JPR265C/-1	265 mm	1.75 mm	16 TPI	0.6 mm (0.9 mm)	6	24	4975364 110299	180

HANDSÄGEN & SÄGEBLÄTTER





HAND SAWS & BLADES

Japan Pull 265 Short Grip



Präzisions-Zugsäge mit Schnellwechsel-System ohne Werkzeug, kurze Elastomergriff.

Precision pull-stroke saw with a Quick-Release blade retainer and a short straight handle with tubular elastomer grip.





Art.Nr.					CASE	MASTER CARTON	EAN	Weight (g) (Packaging + Product)
JPR265ST/-1	230 mm	1.75 mm	16 TPI	0.6 mm (0.9 mm)	6	24	4975364 110305	125

Japan Pull Blade Fluorine Black



Diese Quersäge frisst sich durch alles, dick oder dünn. Schneidet leicht und geradlinig. Eine einzigartige Fluorbeschichtung verhindert Festfressen und das Anhaften von Harz.

This crosscut saw eats through anything, thick or thin. Cuts through well and in a straight line. Unique fluorine coating prevents seizing and adherence of gum.

Art.Nr.					CASE	MASTER CARTON	EAN	Weight (g) (Packaging + Product)
GNB265FBP/-1	265 mm	1.75 mm	16 TPI	0.6 mm (0.9 mm)	12	120	4975364 112545	96





Japan Pull Blades



GNB265P/-1

Premium Federstähle garantieren höchste Qualität für schnelleres Arbeiten. Mit dreifach geschliffener Zahnung.

Premium-grade blades with triple-edge cutting teeth impulse hardened for superior performance.

Art.Nr.					CASE	MASTER CARTON	EAN	Weight (g) (Packaging + Product)
GNB250P/-1	250 mm	1.75 mm	19 TPI	0.5 mm (0.7 mm)	24	120	4975364 060013	56
GNB265STP/-1	230 mm		16 TPI	0.6 mm (0.9 mm)			4975364 015792	60
GNB265P/-1	265 mm	4975364 060037					70	
GNB300P/-1	300 mm	2.15 mm	13 TPI	0.7 mm (1.15 mm)			4975364 060099	100

HANDSÄGEN & SÄGEBLÄTTER

HAND SAWS & BLADES

Japan Pull G-Saw

Sämtliche Griffe sind mit allen Sägeblättern untereinander kombinierbar.

All handles are interchangeable with all blades.

Handles and blades can be freely combined



11

Blade-Funktionen Blade Features					Material-Anwendung Material Suitability Index							
Blade-Funktionen Blade Features												
① GKBG210 / GKBG240	 	Aggressiver Schnitt Aggressive Cut	3.00 mm	9 TPI	0.7 mm (1.0 mm)	★★	—	★★	★★★	★★	—	—
② ALB-A210FB / ALB-A240FB	 				0.8 mm (1.1 mm)							

HANDSÄGEN & SÄGEBLÄTTER

HAND SAWS & BLADES

ALUMINIST® Power-Glide Folding Handle



ALOR-A240FB-EU

Klappsäge mit einzigartigem 9 TPI FLUORO COAT Sägeblatt in ALUMINIST-Ausführung, Komfortabler 2Komponentengriff.

Die-cast aluminum folding handle saws with elastomer grips and tapered 9 TPI Fluoro-Coat blades.



Mehrfach-Positionierung des Sägeblatts. Griff oberhalb des Sägeblatts justierbar. Zum Sägen von der Mitte nach aussen.

Two-Position Blade Fold-Out For positioning the hand even with or above the cutting surface.

Art.Nr.					CASE	MASTER CARTON	EAN	Weight (g) (Packaging + Product)
ALOR-A210FB-EU	210 mm	3.0 mm	9 TPI	0.9 mm (1.2 mm)	4	24	4975364 017819	220
ALOR-A240FB-EU	240 mm						4975364 017826	255

ALUMINIST® Power-Glide Sheath



ALSA-A240FB-EU

Säge mit fixiertem 0,9 mm starkem Sägeblatt im Köcher. Die spezielle FLUORO COAT Beschichtung verhindert das Anhaften von Harz, verbessert die Gleitfähigkeit und schützt zudem vor Rost. ELASTOMER-Griff.

Die-cast aluminum curved handle saws with elastomer grips, tapered 9 TPI Fluoro-Coat™ blades and protective sheaths.

Art.Nr.					CASE	MASTER CARTON	EAN	Weight (g) (Packaging + Product)
ALSA-A210FB-EU	210 mm	3.0 mm	9 TPI	0.9 mm (1.2 mm)	4	24	4975364 017772	280
ALSA-A240FB-EU	240 mm						4975364 017789	290

HANDSÄGEN & SÄGEBLÄTTER

HAND SAWS & BLADES

G-Saw 210 / 240

4x4
TEETH







GKG240B/K1

Klappsäge mit 9 TPI Schnellschnitt-Sägeblatt, ELASTOMER-Griff.

Folding handle saws with elastomer grips and tapered 9 TPI multipurpose blades.

11

Art.Nr.					CASE	MASTER CARTON	EAN	Weight (g) (Packaging + Product)
GKG210B/K1	210 mm	3.0 mm	9 TPI	0.7 mm (1.0 mm)	6	60	4975364 015754	238
GKG240B/K1	240 mm						4975364 015891	265

G-Saw Blade Fluorine Black

FLUORO COAT
BLADE

4x4
TEETH





Extra Thick
0.9 mm



ALB-A240FB

Premium 9 TPI Sägeblätter mit FLUORO COAT Beschichtung.

Premium-grade 9 TPI tapered blades with Fluoro-Coat blade coating.

Art.Nr.					CASE	MASTER CARTON	EAN	Weight (g) (Packaging + Product)
ALB-A210FB	210 mm	3.0 mm	9 TPI	0.9 mm (1.2 mm)	12	120	4975364 017482	46
ALB-A240FB	240 mm						4975364 017499	53

HANDSÄGEN & SÄGEBLÄTTER

HAND SAWS & BLADES

G-Saw Blades





4x4
TEETH

Premium 9 TPI Sägeblätter.

Premium-grade 9 TPI tapered blades.



GKBG240/-1

Art.Nr.					CASE	MASTER CARTON	EAN	Weight (g) (Packaging + Product)
GKBG210/-1	210 mm	3.0 mm	9 TPI	0.7 mm (1.0 mm)	12	120	4975364 015761	36
GKBG240/-1	240 mm						4975364 015907	41

HANDSÄGEN & SÄGEBLÄTTER

HAND SAWS & BLADES

GT-Saw



11

GT-Flush Cut Saw







N-G165FS-EUR

- Extra feiner und präziser Schnitt
- Rutschfester Elastomer-Griff
- Die feinen Zähne schneiden bündig, ohne die umliegenden Oberflächen zu beschädigen

- Extra fine and precision cutting
- Elastomer grip for non-slip gripping and comfort
- Rip cut saw teeth can cut flush without damaging surrounding surfaces.



Art.Nr.					CASE	MASTER CARTON	EAN	Weight (g) (Packaging + Product)
N-G165FS-EUR	165 mm	0.95 mm	27 TPI	0.3 mm (0.3mm)	12	72	4975364 112941	190
NK-G165FS-EUR					24	120	4975364 112958	30

HANDSÄGEN & SÄGEBLÄTTER

HAND SAWS & BLADES

GT Jab-Saw



N-G165JS-K1





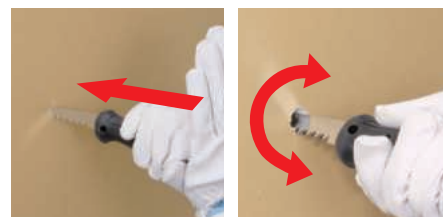

Einzigartige stahlverstärkte kleine Metallsäge mit ergonomischem Elastomergriff und einem austauschbaren, extra robusten 1,2-mm-Sägeblatt mit messerscharfen Schneidezähnen in Doppelreihe.

Unique, steel-reinforced jab saw that features an ergonomic elastomer handle and a replaceable extra heavy-duty 1.2 mm thick blade with twin rows of razor-sharp cutting teeth.



Durch die Trockenwand stechen und grob schneiden

Push it through the drywall and make a rough cut

Art.Nr.					CASE	MASTER CARTON	EAN	Weight (g) (Packaging + Product)
N-G165JS-K1	165 mm	3.75 mm	7 TPI	1.8 mm (2.1mm)	12	72	4975364 112705	143
NK-G165JS-1					24	120	4975364 112712	32

KARTUSCHENPRESSEN

CAULK GUNS

CONVOY®

Gleichmäßiger und zuverlässiger Materialfluss. Drehbarer Griff für Arbeiten an schwer zugänglichen Stellen. Extralange Halbschale für mühelosen Kartuschenwechsel. Mit dem verstellbaren Vorschub lassen sich nahezu alle Materialien gut verarbeiten.

Smooth and dependable caulk guns with rotating handles for maneuvering in and around tight spaces, extra-long barrels for hassle-free tube reloads, and featuring thrust system options to handle any material with ease.



12

Vorschubsystem / Thrust System

DP Dual Power

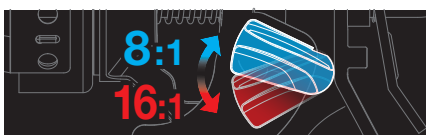

Bei zähen Materialien drücken Sie den Schieber nach unten, bei weichen Materialien drücken Sie den Schieber nach oben. Durch Drücken des Schiebers nach unten, erhöht sich die Übertragungskraft um 40%.

For hard materials, pull down the lever, for soft materials, push up the lever. By pulling down the lever, thrust force increases about 40%.

Enhanced SST Enhanced SST



20% mehr Kontaktfläche zwischen Kolbenstange und Vorschubhülse gewährleistet direkte Kraftübertragung ohne Verluste. Dies führt zu deutlich höherer Lebensdauer.

By increasing 20% of contact surface between plunger and valve plate, the thrust force is transmitted to the plunger without reduction. This results in higher durability.

TT System Twin Thrust System

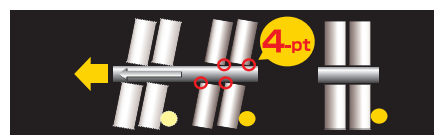

Die 4 Kanten der Vorschubhülse verstärken die Kraftübertragung auf den Kolben. Dadurch können zähe Materialien einfach verarbeitet werden.

4 edges of valve plates strengthen the thrust force on the plunger. It helps to use hard materials with ease.

Funktionen / Functions

360° RH 360° Rotating Handle

Für einfache Handhabung in beengtem Arbeitsumfeld.

For maneuvering in and around tight spaces.



AFS System Auto Flow Stop System

Kolben zieht sich nach jedem Hub um einige Millimeter zurück. Materialfluss wird effizient und schnell gestoppt.













Plunger goes back a few millimeters after every push to stop the flow efficiently and quickly.



KARTUSCHENPRESSEN

CAULK GUNS

Funktionsliste / Function List

Spezifikationen und Funktionen Specifications and Functions	Inhalt der Abdichtungsmaterialien Caulking material sizes	Materialien Materials		Vorschubsystem Thrust System	Funktionen Functions
		Halbschale Barrels	Griffe Grips		
CONVOY® Serie CONVOY® Series CONVOY® Bulk Super 3Way  P82	 Bis zu 550 ml loses Material Pail = up to 550 ml  Beutel bis zu 400 ml Sausage pack = up to 400 ml  Kartusche = 300 ml Cartridge = 300 ml	Aluminium aluminium		Enhanced SST	—
CONVOY® Super Sausage 2way  P82	 Beutel bis zu 600 ml Sausage pack = up to 600 ml  Kartusche = 300 ml Cartridge = 300 ml	Metall / Kleber- und Dichtungsmaterial Metal / Resin	TT System	AFS System	
CONVOY® RS  P83	Kartusche = 310 ml Cartridge = 310 ml				Kleber- und Dichtungsmaterial Resin
CONVOY® Super 26  P83	CNV100SP26-R1 Kartusche = 310 ml Cartridge = 310ml CNV900SP26-R1 Kartusche = 900 ml Cartridge = 900 ml	Metall Metal	Enhanced SST	—	
CONVOY® Super 12  P84	Kartusche = 310 ml Cartridge = 310 ml			Metall / Kleber- und Dichtungsmaterial Metal / Resin	TT System
CONVOY® Just  P84	Kartusche = 310 ml Cartridge = 310 ml	Kleber- und Dichtungsmaterial Resin	TT System	AFS System	
CONVOY® J900  P85	Kartusche = 900 ml Cartridge = 900 ml	Kleber- und Dichtungsmaterial Resin			TT System
CONVOY® Lite  P85	Kartusche = 310 ml Cartridge = 310 ml	Kleber- und Dichtungsmaterial Resin	TT System	AFS System	

KARTUSCHENPRESSEN

CAULK GUNS

CONVOY® Bulk Super 3Way

Enhanced SST 360° RH



Standardzubehör

Standard accessories

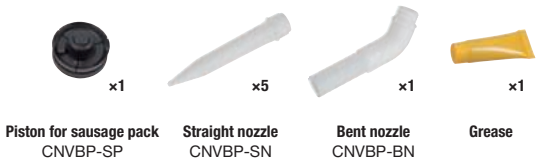

Drei-Wege-Kartuschenpistole für drei Nachfüllarten: Lose, Beutel und Kartuschen. Einfacher Wechsel des Kolbens durch Drücken des Kugelkopfes. Das SST-System macht es einfach, hochviskose Materialien zu verwenden. Robuster Griff aus Aluminiumdruckguss. Die Gummidichtung am Kolben sorgt dafür, dass kein Dichtungsmaterial in der Kartuschenpresse zurückbleibt. Ausgestattet mit Tropfschutz-System.

3way caulking gun with three refill types: bulk, sausage pack and cartridge. Just touch a button to switch to the right piston for your refill type. SST system makes it easy to use high-viscosity materials. Durable die-cast aluminum trigger and grip. A rubber gasket on the piston ensures that no caulking material leaks back into the gun. Fitted with a drip-prevention mechanism.

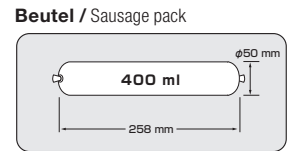
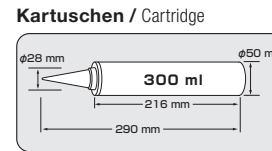

Art.Nr.					FEATURES	CASE	MASTER CARTON	EAN	Weight (g) (Packaging + Product)
CNVBSP3W550/R1	10 : 1	300 ml	400 ml	Up to 550 ml max	Enhanced SST System	1	4	4975364 260192	1,280

CONVOY® Super Sausage 2way

TT System 360° RH AFS System



Standardzubehör

Standard accessories

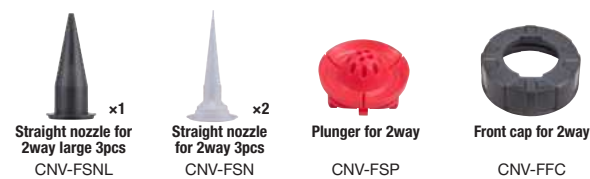

- Zwei-Wege-Kartuschenpresse für Beutel und Kartuschen
- Wechselbare Vorschubeinheit
- Einzigartig gestaltete Frontkappe ermöglicht das vollständige Entleeren des Materials
- Rückstandsfreie Oberfläche

- Compatible with sausage and cartridge refills
- Removable plunger
- Uniquely designed front cap enables every ounce of material to be released from the tube
- Anti-residue surface

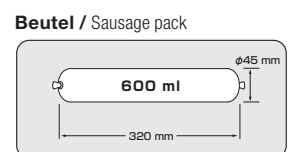
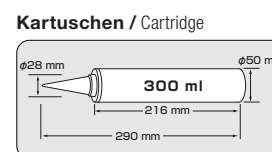

Art.Nr.				FEATURES	CASE	MASTER CARTON	EAN	Weight (g) (Packaging + Product)
CNV-FSP600-R1	12 : 1	300 ml	600 ml	Quick Plunger	4	16	4975364 266422	1,060

KARTUSCHENPRESSEN CAULK GUNS

CONVOY® RS

DP **Enhanced SST** **360° RH**



Übertragungsrate individuell einstellbar, Kartuschenpresse mit extra langer Trommel, 360° drehbarer Griff und extra langer Ausstechnadel. Zum einfachen Dosieren von zähflüssigen Materialien.

Switchable thrust force caulk gun with extra-long barrels, 360° rotating handles, and extra-long seal puncture pins. For dispensing thick, viscous materials.

Dual Power



Enhanced SST

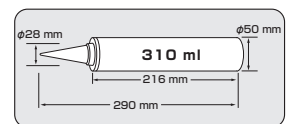

Art.Nr.			FEATURES	CASE	MASTER CARTON	EAN	Weight (g) (Packaging + Product)
CNV100RS/B1	8 : 1 16 : 1	310 ml	Dual Power Enhanced SST System	6	24	4975364 168559	760

CONVOY® Super 26

Enhanced SST **360° RH**



CNV100SP26/R1



CNV900SP26-R1

Die Kartuschenpresse für sehr zähflüssige Materialien. Neue Mechanik für ausgezeichnete Auspresskraft. Ausgereifter Griff- und Bedienungskomfort mit 360°Drehfunktion und rutschfestem Griff. Zusätzlich verstärktes Gehäuse und Verschweissungen.

Extra-high thrust caulk guns with extra-long barrels, 360° rotating handles with elastomer non-slip grips, and extra-long seal puncture pins. For dispensing extra-thick, viscous materials.

Enhanced SST



CNV100SP26/R1

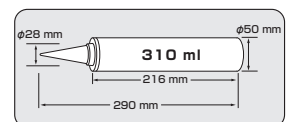

CNV900SP26-R1

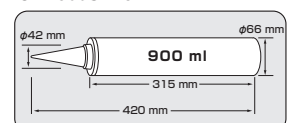

Art.Nr.			FEATURES	CASE	MASTER CARTON	EAN	Weight (g) (Packaging + Product)
CNV100SP26/R1	26 : 1	310 ml	Enhanced SST System	6	24	4975364 165619	900
CNV900SP26-R1		900 ml		4	16	4975364 165633	1,005

KARTUSCHENPRESSEN

CAULK GUNS

CONVOY® Super 12

TT
System

360°
RH

AFS
System



Extrarobuste Kartuschenpresse für maximale Leistung, Kraftvolles Twin Thrust-System, 360° Rotations-Trommel, Automatische Unterbrechung des Materialflusses durch Auto Flow Stop.

Max performance caulk gun with an extra-long barrel, a powerful Twin Thrust dispensing system, Auto Flow Stop, and a 360° rotating handle.

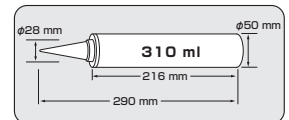
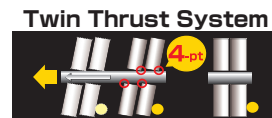

Art.Nr.			FEATURES	CASE	MASTER CARTON	EAN	Weight (g) (Packaging + Product)
CNV100SP12/R1	12 : 1	310 ml	Twin Thrust System	6	24	4975364 067302	820

CONVOY® Just

TT
System

360°
RH

AFS
System



Extralange Kartuschenpresse für optimale Leistung, Kraftvolles Twin Thrust-System, 360° Rotations-Trommel, Automatische Unterbrechung des Materialflusses durch Auto Flow Stop.

Extra-long barrel caulk gun with a powerful Twin Thrust dispensing system, Auto Flow Stop, and a 360° rotating handle.

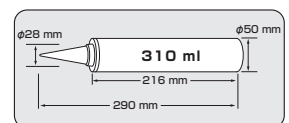

Art.Nr.			FEATURES	CASE	MASTER CARTON	EAN	Weight (g) (Packaging + Product)
CNV-JUST/Y1	7 : 1	310 ml	Twin Thrust System	6	24	4975364 066954	600

KARTUSCHENPRESSEN

CAULK GUNS

CONVOY® J900



Extragrosse Kartuschenpresse für übergrosse Kartuschen, Kraftvolles Twin Thrust-System, 360° Rotations-Trommel, Automatische Unterbrechung des Materialflusses durch Auto Flow Stop.

Extra-long barrel caulk gun for large size tubes that features a powerful Twin Thrust dispensing system, Auto Flow Stop, and a 360° rotating handle.

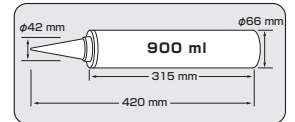
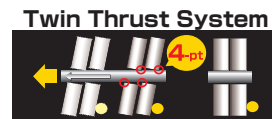

Art.Nr.			FEATURES	CASE	MASTER CARTON	EAN	Weight (g) (Packaging + Product)
CNVJ900/YEUSA	7 : 1	US QUART (900 ml)	Twin Thrust System	4	16	049296065911(UPC)	900

CONVOY® Lite



Ultraleichte Kartuschenpresse mit Drehverschluss für einfachen Kartuschenwechsel, Kraftvolles Twin Thrust-System, Automatische Unterbrechung des Materialflusses durch Auto Flow Stop.

Ultra-light caulk gun with a unique twist-lock barrel removal system for fast and easy tube changes, a powerful Twin Thrust dispensing system, and Auto Flow Stop.

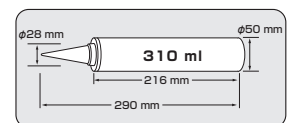

Art.Nr.			FEATURES	CASE	MASTER CARTON	EAN	Weight (g) (Packaging + Product)
CNV100LT/K1	7 : 1	310 ml	Twin Thrust System	6	24	4975364 066282	480

12

MARKIER WERKZEUGE

MARKING TOOLS

Precision Snap Line Systems



13

Line Thickness	1.0 mm		1.8 mm		2.8 mm	
Line Length	1.0 mm		1.8 mm		2.8 mm	
45 m					CR604S-D1 	
30 m					PLITOL-EUR 	
Replacement Snap Line	PLITOL-EUR 		PLITOLL-1 		PL-ITO3L-1 	

MARKIER WERKZEUGE

MARKING TOOLS

CHALK-RITE® Dura III



Integrated handle release
Die-cast aluminum Case



- Hochwertige, satten Strich
- Große, auslaufsichere Nachfüllöffnung
- Ergonomisch gestaltetes, stoßfestes Gehäuse
- Doppelt so schnell durch zweifach übersetzten Aufrollmechanismus

- Specially crafted woven snap line
- Large, leak-proof refill port
- Ergonomically designed shock-resistant case
- Double-speed winding mechanism

Art.Nr.	LINE LENGTH	POWDER CAPACITY	CASE	MASTER CARTON	EAN	Weight (g) (Packaging + Product)
CR604S-D1	2.8 mm × 45 m	709g	1	12	4975364 058706	880

CHALK-RITE® Dura II



Integrated handle release
Die-cast aluminum Case



- Premium geflochtene snp Schnur
- Doppelt so schnell durch zweifach übersetzten Aufrollmechanismus

- Premium braided snap line
- Double-speed winding mechanism

Art.Nr.	LINE LENGTH	POWDER CAPACITY	CASE	MASTER CARTON	EAN	Weight (g) (Packaging + Product)
CR503S-D1	1.8 mm × 30 m	80g	4	24 (6 sets)	4975364 058690	1,660 (345/pc)

CHALK-RITE® Dura



Integrated handle release
Die-cast aluminum Case



- Premium geflochtene snp Schnur
- Doppelt so schnell durch zweifach übersetzten Aufrollmechanismus

- Premium braided snap line
- Double-speed winding mechanism

Art.Nr.	LINE LENGTH	POWDER CAPACITY	CASE	MASTER CARTON	EAN	Weight (g) (Packaging + Product)
CR401S/D1	1.0 mm × 30 m	60g	4	24 (6 sets)	4975364 057402	1,480 (300/pc)

MARKIER WERKZEUGE

MARKING TOOLS

CHALK-RITE® Gear Drive



Smooth and durable
Die-cast aluminum Case



- Mit geflochtener Schnur gegen Verdrehen
- Schnelles Einrollen durch Übersetzung 1 : 5

- Premium braided snap line
- Smooth-running five-gear winding mechanism

Art.Nr.	LINE LENGTH	POWDER CAPACITY	CASE	MASTER CARTON	EAN	Weight (g) (Packaging + Product)
CR201R-D1	1.0 mm × 30 m	55g	4	24 (6 sets)	4975364 058959	1,320 (260/pc)

CHALK-RITE® Jam Free



Smooth and durable
ABS CASE



- Geflochtene Schnur gegen Verdrehung

- Jam-Free braided line

Art.Nr.	LINE LENGTH	POWDER CAPACITY	CASE	MASTER CARTON	EAN	Weight (g) (Packaging + Product)
CR301JF/D1	1.0 mm × 30 m	70g	4	24 (6 sets)	4975364 057136	1,880 (200/pc)

CHALK-RITE® Snap Line



PL-ITO3L-1

PLITOLL-1

PLITOL-EUR

PLITOS-EUR



Premium Ersatzschnüre für TAJIMA-Schlagschnurgeräte Chalk-Rite. Gedreht aus Polyester und Nylon.

Premium braided nylon / polyester lines for Chalk-Rite chalk snap lines.

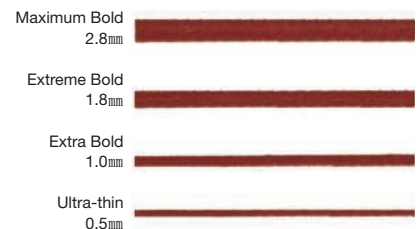

Art.Nr.	LINE LENGTH	FEATURES	CASE	MASTER CARTON	EAN	Weight (g) (Packaging + Product)
PL-ITO3L-1	2.8 mm × 45 m	Maximum Bold	1	20	4975364 058720	230
PLITOLL-1	1.8 mm × 30 m	Extreme Bold	10	100	4975364 058713	46
PLITOL-EUR	1.0 mm × 30 m	Extra Bold			049296054359 (UPC)	23
PLITOS-EUR	0.5 mm × 30 m	Ultra Thin			049296054342 (UPC)	19

WERKZEUGE FÜR DEN INNENAUSBAU

DRYWALL TOOLS

Drywall Beveling Tools



18 mm Cutterklingen einsetzbar.

Uses 18 mm / 3/4" wide blades

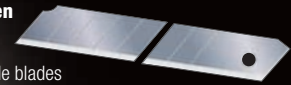

Arbeitstiefe von 1- 3 mm einstellbar in 4 Stufen.

4-step bevel depth adjustment from 1 mm to 3 mm.

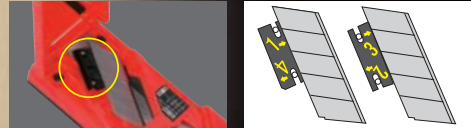

Einstellbare Arbeitstiefen

Blade Depth Adjustment Plate Settings.

Nr.	1	2	3	4
	1.0 mm	1.5 mm	2.0 mm	3.0 mm

Werkzeuggest mit FLUORO COAT-Beschichtung für sanftes Arbeiten. Robuster Aluminium-Kern.

Fluoro-Coat base for smooth operation. Rugged die-cast aluminum core.



Drywall Beveling Tools

120 / 180



TBK180H45/R1



TBK120H45/R1



Arbeitstiefen sind bei TAJIMA Kantenhebeln mit 18 mm Cutterklingen einstellbar.

Adjustable bevel depth drywall plane uses 18 mm wide blades.

Zubehör

- 18 mm ENDURA Klinge
- Einstellwerkzeug für Klinge.

Accessoires

- One 18 mm Endura Blade
- Blade Resizing Tool

Dual-purpose

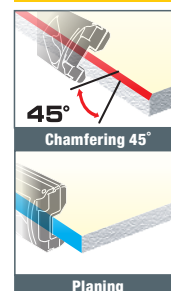

Art.Nr.			CASE	MASTER CARTON	EAN	Weight (g) (Packaging + Product)
TBK120H45/R1	120 mm	max 15 mm	6	36	4975364 056603	130
TBK180H45/R1	180 mm				4975364 056610	240

WERKZEUGE FÜR DEN INNENAUSBAU

DRYWALL TOOLS

Combination Drywall Rasp

Tetra-Teeth

Drei unterschiedliche Sektoren.
Three grinding sections

- 1 Seitliche Zahnung
Side-rail Teeth
- 2 Feine Zahnung
Fine Teeth
- 3 Grobe Zahnung
Coarse Teeth

Spanfrei arbeiten in beide Richtungen.
Clog-free dual-action

Späne werden im Griff aufgefangen.
In-handle dust collection



14

Combination Drywall Rasp



Spanfrei arbeiten in beide Richtungen.

Clog-free dual-action Tetra Teeth drywall rasp.

Art.Nr.			CASE	MASTER CARTON	EAN	Weight (g) (Packaging + Product)
TBYD180/-1	180 mm	max 25.4 mm	6	36	4975364 056665	180

WINKELMESSER ANGLE METER

Angle Meter Slant



Slant 100 / AL200M



SLT100/-E



SLTAL200M/K1



Winkelmesser mit rotierender Doppelskala für Einhand-Messung von Neigung oder Winkel.

Rotating dual scale angle meters provide one-hand measurement of slant or angles.



SLTAL200M/K1

Mit Magnet und Aluminiumrahmen
With magnet and aluminum frame

Art.Nr.		ACCURACY	SCALE SPECIFICATIONS	CASE	MASTER CARTON	EAN	Weight (g) (Packaging + Product)
SLT100/-E	130° - 0 - 130°	±1°	2°	6	36	4975364 040831	275
SLTAL200M/K1						4975364 065858	460

HANDLOTE

LAYOUT TOOLS

Layout Tools

PLUMB-RITE®



PLUMB-RITE® 400GP

Universal-Handlot mit automatischem Einzug, Gehäuse mit Elastomer-Ummantelung, Lot mit 400 g Schnell-Stabilisator.

All-in-one plumb alignment and centering tool with a self-retracting line, elastomer-wrapped case, reinforced setting pin head and a 400 g / 14 oz Quick Stabilizing bob.

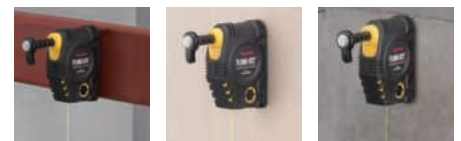

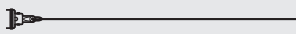

Art.Nr.			CASE	MASTER CARTON	EAN	Weight (g) (Packaging + Product)
PZB400GPY/D1	400 g	1.2 mm x 4.5 m	6	24 (4 sets)	4975364 055088	4,800 (750/pc)

PLUMB-RITE® 400

Universal-Handlot mit automatischem Einzug, Lot mit 400 g Schnell-Stabilisator.

All-in-one plumb alignment and centering tool with a self-retracting line and a 400 g / 14 oz Quick Stabilizing bob.



Art.Nr.			CASE	MASTER CARTON	EAN	Weight (g) (Packaging + Product)
PZB400Y/D1	400 g	1.2 mm x 4.5 m	6	24 (4 sets)	4975364 055071	4,600 (710/pc)

PLUMB-RITE® 300

Universal-Handlot mit automatischem Einzug, Lot mit 300 g Schnell-Stabilisator.

All-in-one plumb alignment and centering tool with a self-retracting line and a 300 g / 10 oz Quick Stabilizing bob.

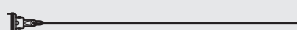

Art.Nr.			CASE	MASTER CARTON	EAN	Weight (g) (Packaging + Product)
PZB300Y/D1	300 g	0.9 mm x 3.0 m	6	24 (4 sets)	4975364 055064	3,200 (480/pc)

INDEX

Item Code	Page		Page		Page
305D60/A1	49	CNV-JUST/Y1	84	DK-BD120-EUR	60
500C40/A1	47	CONVEX-SET1	12 • 35	DK-BT70-EUR	60
501A40/A1	47	CPG175B/Y1	57	DKC-L590W-EUR	40 • 61
520H40/A1	48	CR201R-D1	88	DK-FKSD-EUR	58
521H40/A1TAG	48	CR301JF/D1	88	DK-MSFHS-EUR	59
A		CR401S/D1	87	DKTN80X/W1	59
AC500S-EUR	38	CR503S-D1	87	DK-TNMN-EUR	59
AC501S-EUR	38	CR604S-D1	87	E	
AC700S-EUR	38	CTGSL300/K1	55	EA-50HC	28
AC701S-EUR	38	CTGSL600/K1	55	EE3-10HC	33
ALB-A210FB	76	CTGSL1000/K1	55	EH-20HC	31
ALB-A240FB	76	D		EL-50HC	29
ALOR-A210FB-EU	75	DC50SFC/Y1	35 • 37	EPK10MW1E01	22
ALOR-A240FB-EU	75	DC360Y-EUR	36	EPK10MW2E01	22
ALSA-A210FB-EU	75	DC395BK-EUR	50	EPK10MW3E10	22
ALSA-A240FB-EU	75	DC560RB13D12/Y1	36	EPK10MW4E01	22
C		DC560Y-EUR	36	EPK20MW1E01	22
CB62H/B1	30	DC561RB13D12/Y1	36	EPK20MW2E01	22
CB65RBC/K1	32	DC561Y-EUR	36	EPK20MW3E10	22
CB93H/Y1	54	DC610-Y1-10	45	EPK20MW4E01	22
CLP160B/Y1	56	DC660W-EUR	43	EPK30MW1E10	22
CLP210B/Y1	56	DC661W-EUR	43	EPK30MW3E10	22
CNV100LT/K1	85	DC680-Y1-10	45	EPK30MW4E01	22
CNV100RS/B1	83	DC690-Y1-10	44	G	
CNV100SP12/R1	84	DFC560W-EUR	34	G3GLM27-50EB-EUR	12
CNV100SP26/R1	83	DFC561W-EUR	34	G3GLM27-80EB-EUR	12
CNV900SP26-R1	83	DFC579-SY-EUR	35	G3GLWM25-50EB-EUR	10
CNVBSP3W550/R1	82	DFC670-SW-EUR	39	GAG3L25-50D-EUR	6
CNV-FSP600-R1	82	DFC671-SW-EUR	39	GAG3L27-75D-EUR	6
CNVJ900/YEUSA	85	DKBB50B/W1	61	GASP25-50EB-EUR	7

INDEX

Item Code	Page		Page		Page
GKBG210/-1	77	HTN50MW3A10	21	LC520Y-EUR	48
GKBG240/-1	77	J		LC521Y-EUR	48
GKG210B/K1	76	JPR265AFB-R1	71	LC560Y-EUR	42
GKG240B/K1	76	JPR265A/R1	71	LC561Y-EUR	42
GL16-30E-EUR	14	JPR265C/-1	72	LC620Y-EUR	48
GL19-50EB-EUR	14	JPR265D/K1	71	LC650Y-EUR	47
GL25-50D-EUR	15	JPR265FBR/Y1	72	LC660Y-EUR	42
GL25-50EB-EUR	14	JPR265R/Y1	72	LC661Y-EUR	42
GL25-70EB-EUR	14	JPR265ST/-1	73	LC959X/Y1	54
GL25-75D-EUR	15	JPR300A/R1	71	LCB30C/Y1	28
GL25-80EB-EUR	14	JPR300/K1	71	LCB30RBC/K1	28
GL25-100D-EUR	15	L		LCB30SC/Y1	28
GL25-100EB-EUR	14	L16-30E1-EUR	8	LCB50C/Y1	29
GLM25-50EB-EUR	15	L16-30E-EUR	16	LCB50DC/Y1	29
GLPYR-SET2	14	L16-50E-EUR	16	LCB50RBC/K1	30
GLPYR-SET3	14	L19-50EB-EUR	16	LCB50SN/YE	29
GNB250P/-1	73	L25-50E1-EUR	8	LCB65C/Y1	31
GNB265FBP/-1	73	L25-50EB-EUR	16	LCB65N/Y1	31
GNB265P/-1	73	L25-70EB-EUR	16	LCB65RBC/K1	32
GNB265STP/-1	73	L25-100E-EUR	16	LCB65S-10H/Y1	31
GNB300P/-1	73	LB30N/-1	28	LCM500BK-EUR	41
H		LB50N/-1	29	LKT-F02R	19
H13-20EN-EUR	17	LC301-EUR	49	LKT-F05R	19
HKB-10B/Y1	52	LC303B-EUR	46	M	
HKB-50B/Y1USA	52	LC303Y-EUR	46	MG300FB/REEU	71
HSP30MW3A10	21	LC390-EUR	51	N	
HSP50MW3A10	21	LC500B-EUR	47	N-G165FS-EUR	78
HTN30MW2A01	21	LC500Y-EUR	47	N-G165JS-K1	79
HTN30MW3A10	21	LC501B-EUR	47	NK-G165FS-EUR	78
HTN50MW2A01	21	LC501Y-EUR	47	NK-G165JS-1	79

INDEX

Item Code	Page		Page		Page
NMY13-20D-EUR	18	SCRL200/Y1	67	V	
P		SCRL300/Y1	67	VR101R-EUR	53
PHR250F80/W1	64	SCRL600/Y1	67	VR102B-EUR	53
PHR250H80/W1	65	SCRM75/Y1	67	VR103S-EUR	53
PHR500H80/W1	65	SCRN95/Y1	66	VRB2-10B/Y1	52
PHR-FB80/-1	65	SF-BHLD-EUR	11	VRB2-50B/Y1	52
PHR-HB80/-1	65	SFG3GLWM2570EB-EUR	11	VRB2-100B/Y1	52
PIT-10C-EUR	18	SLT100/-E	91	Z	
PIT-20C-EUR	18	SLTAL200M/K1	91	ZL25-50EB-EUR	13
PIT-30FRC-EUR	18	SS001/Y1	32	ZL25-80EB-EUR	13
PIT-50C-EUR	18	SSS16-30EB-EUR	9		
PL-ITO3L-1	88	SSS19-50EB-EUR	9		
PLITOL-EUR	88	SYL30MTBG01E	24		
PLITOLL-1	88	SYL50MT3G15	24		
PLITOS-EUR	88	SYR30MT3G15	24		
PSCL300A/W1	63	SYR50MT3U15TAG	24		
PSCL300F/W1	62	SYS20MT2E01E	25		
PSCL500A/W1	63	SYS20MT3U15TAG	25		
PZB300Y/D1	93	SYS50MT3B15	25		
PZB400GPY/D1	92	T			
PZB400Y/D1	93	TBK120H45/R1	89		
R		TBK180H45/R1	89		
RBA-50HC	28	TBYD180/-1	90		
RBE3-10HC	33	TOP13-20EK-EUR	17		
RBH-20HC	32	TOP13-20N-EUR	17		
RBL-50HC	30	TOP13-30EK-EUR	17		
S		TOP13-35EK-EUR	17		
SCRC50/Y1	66	TOP13-35N-EUR	17		
SCRC75/Y1	66	TOP13-50EK-EUR	17		
SCRH1200/Y1	67	TOP13-55N-EUR	17		

Verkaufswand

ATTRACTIVE DISPLAY PROPOSAL

Für die Warenpräsentation
For Product Presentation

Aufsteller

Display



2200 mm

500 mm



2280 mm

1050 mm

420 mm



165 mm

140 mm

225 mm

DS-100



550 mm

350 mm

250 mm

DS-201



820mm

350mm

350mm

Display : G Lock Pyramiden-Aufsteller

Display : G Lock Payramid Set



395 mm

320 mm

320 mm

GLPYR-SET2



395 mm

320 mm

320 mm

GLPYR-SET3

Verkaufswand

ATTRACTIVE DISPLAY PROPOSAL

Banner

Banner



TAJIMA Logo Aufkleber

TAJIMA Logo Stickers



TAJIMA

Als Hersteller von Maßbändern im Jahre 1909 gegründet, produziert TAJIMA heute über 1000 Premium-Handwerkzeuge unter der Marke TAJIMA.

TAJIMA ist mittlerweile ein multinationales Unternehmen mit weltweiten Produktionsstätten.

Die ambitionierten Vorstellungen von exzellentem Design, der Auswahl der Materialien, der Produktions- und Qualitätskontrollverfahren gelten für alle Werkzeuge als höchster Standard.

Alle TAJIMA Mitarbeiter stellen sicher, dass Funktion, Qualität, Form und Design der Werkzeuge die Wünsche und Erwartungen der Anwender erfüllen.

TAJIMA Markenwerkzeuge sind weltweit anerkannt für außergewöhnliche Produkt-Eigenschaften und Funktion auf höchstem Qualitätsniveau, so wie es in der heutigen Industrie nur noch selten zu finden ist.

Founded in 1909 as a manufacturer of steel and woven measuring tapes, TJM Design Corporation now produces over 1,000 premium-grade hand tools under the Tajima brand. A multinational organization with global production facilities, TJM Design Corporation continues its commitment to excellence in the design, selection of materials, production and quality control processes that govern the manufacture of its tools. And all TJM Design Corporation staff are dedicated to ensuring that the function, quality, shape and design of Tajima tools fulfills the desires and expectations of the end user. As a result, Tajima brand tools are recognized worldwide as offering exceptional feature and function at a high level of quality rarely seen in today's industry.



Tajima

TJM Design Corp.

3-4-3 Azusawa
Itabashi-ku, Tokyo 174-8503 Japan
Tel: +81-3-3969-6603
Fax: +81-3-3969-7402

No.FGB 2150 January, 2026
Printed in Japan

**TAJIMA AG
TAJIMA TOOL EUROPE**

Stansstaderstrasse 54
CH-6370 Stans Suisse
www.tajima.eu.com
Tel: +41 41 619 7010
Fax: +41 41 619 7011
info@tajima.eu.com



@tajimatoolurope



@TAJIMATOOLEUROPE