

# TaJima

2026



# INDEX

**01 MESURES COURTES**  
POCKET TAPES **3-18**

**02 MESURE AU LASER**  
LASER DISTANCE METER **19**

**03 MESURES LONGUES**  
LONG TAPES **20-25**

**04 LAMES DE RECHANGE POUR CUTTERS**  
CUTTER KNIFE BLADES **26-33**

**05 CUTTERS**  
CUTTER KNIVES **34-51**

**06 LAMES DE COUTEAUX UTILITAIRES**  
UTILITY KNIFE BLADES **52**

**07 COUTEAUX**  
UTILITY KNIVES **53**

**08 COUTEAU DE SECURITE**  
SAFETY KNIFE **54**

**09 PRODUITS SPÉCIAUX**  
SPECIALTY TOOLS **55-61**

**10 GRATTOIRS**  
SCRAPERS **62-67**

**11 SCIES A MAIN ET LAMES**  
HAND SAWS & BLADES **68-79**

**12 PISTOLETS POUR CARTOUCHES A MASTIC**  
CAULK GUNS **80-85**

**13 OUTILS DIVERS**  
MARKING TOOLS **86-88**

**14 OUTILS DE PLAQUISTES**  
DRYWALL TOOLS **89-90**

**15 GONIOMETRES**  
ANGLE METER **91**

**16 FILS A PLOMB**  
LAYOUT TOOLS **92-93**

**MESURES COURTES**  
POCKET TAPES  **01**

**MESURE AU LASER**  
LASER DISTANCE METER  **02**

**MESURES LONGUES**  
LONG TAPES  **03**

**LAMES DE RECHANGE POUR CUTTERS**  
CUTTER KNIFE BLADES  **04**

**CUTTERS**  
CUTTER KNIVES  **05**

**LAMES DE COUTEAUX UTILITAIRES**  
UTILITY KNIFE BLADES  **06**

**COUTEAUX**  
UTILITY KNIVES  **07**

**COUTEAU DE SECURITE**  
SAFETY KNIFE  **08**

**PRODUITS SPÉCIAUX**  
SPECIALTY TOOLS  **09**

**GRATTOIRS**  
SCRAPERS  **10**

**SCIES A MAIN ET LAMES**  
HAND SAWS & BLADES  **11**

**PISTOLETS POUR CARTOUCHES A MASTIC**  
CAULK GUNS  **12**

**OUTILS DIVERS**  
MARKING TOOLS  **13**

**OUTILS DE PLAQUISTES**  
DRYWALL TOOLS  **14**

**GONIOMETRES**  
ANGLE METER  **15**

**FILS A PLOMB**  
LAYOUT TOOLS  **16**



Tajima 



# MESURES COURTES

## POCKET TAPES

01



### Qualite Optimale / Premium Features

#### Strong Tape

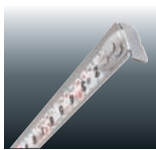

Ruban en acier plus épais offrant une meilleure rigidité que les mesures classiques.

Extra thick steel generates more stiffness than standard tape measures.



#### Tethering Straps



Dragone résistante à mettre au poignet ou suspendre à un crochet ou clou.

Strong straps for wrist or to tether on a hook or nail.



#### Double-sided tapes



Rubans avec graduations recto/verso permettant des mesures précises dans toutes les situations.

Double-sided tapes provide accurate readability for all applications.



#### Strong Belt Clips



Agrafes de ceinture résistantes en acier à ressort de première qualité.

Premium spring-steel belt clips for dependable performance.



#### Double Lock System



Strong Tape : verrouillage automatique quand le ruban est sorti. Il suffit d'appuyer sur le bouton de verrouillage pour un blocage ferme du ruban.

Strong Tape automatically locks when extended. You only need to press Lock Button to completely fix the tape.



#### Safety Belt Holder



Le support de ceinture à ajustement rapide vous permet d'attacher et détacher le boîtier sur le support avec une seule main.

The quick-fit belt holder enables you to attach & detach the housing on the holder with one hand.



# MESURES COURTES

## POCKET TAPES

01

### Revêtement mélange polyester / Polyester-Blend Coating



**Revêtement du ruban innovant pour une plus grande protection antiabrasive, 2 fois supérieure aux revêtements de ruban classiques.**

Innovative tape coating provides advanced protection against abrasion, 2 times greater than standard tape coatings.



### Etat du ruban après simulation à l'abrasion

Tape condition after abrasive-wear simulation

**Tajima**



**A**



**B**



### CROCHET COULISSANT RENFORCE / Superior End Hook

#### Unique 3-Rivet Attachment



**Fixation du crochet à triple rivets avec plaque de renfort indépendante en acier fixée par 4 rivets.**

Triple-riveted end hook secured with an independently riveted steel back plate.

#### Reliable Self-Adjustment

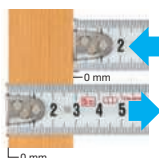

**Crochet coulissant permettant des mesures toujours précises intérieures comme extérieures.**

Freely moving end hook ensures consistently accurate inside and outside measurements.

#### Strong Hook

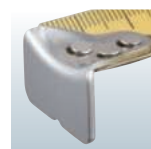

**Epaisseur 1,6 mm 4,7 fois plus résistant que les modèles standards.**

Thickness 1.6 mm 4.7 times stronger than standard model.

#### Ultra Hard End Hook



**Crochets en acier trempé deux fois plus rigide et résistant que les crochets classiques.**

Unique tempered steel end hooks are twice as hard and durable as traditional end hooks.

#### Magnetic End Hook



**Double Aimant en matière rare d'une puissance magnétique de 2600 Gb.**

Powerful twin rare-earth magnets generate 2600 Gb of magnetic hold.

#### Double Magnetic























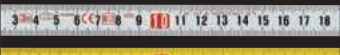























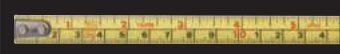

**Ruban à mesurer à base magnétique unique avec crochets magnétiques à l'extrémité**

Unique magnetic base tapemeasures with magnetic end hooks

# MESURES COURTES

## POCKET TAPES

01

|  |  Width |                   |                 |  |  |                      |                      |
|--|---|--|--|---|---|----------------------|----------------------|
| EC Class<br><b>1</b>   | 16 mm   | standard tape  |                 |    | 1.5m  | 2.3m                 |                      |
|  | 25 mm   |  |                 |    | 2.4m  | 3.8m                 |                      |
| EC Class<br><b>2</b><br> Double-sided tapes | 16 mm   | standard tape  |                 |    | 1.5m  | 2.3m                 |                      |
|  | 19 mm   |  |                 |    | 1.8m  | 2.8m                 |                      |
|  | 25 mm   | Strong Tape<br>   | standard tape  |    |   | 2.4m<br>(10m : 2.1m) | 3.8m<br>(10m : 3.4m) |
|  |   |  | Strong Tape<br> |    |    | 2.4m                 | 3.6m                 |
|  |   |  | Strong Tape<br> |    |    | 2.6m                 | 3.9m                 |
|  | 27 mm   | Strong Tape<br> |                 |  | 2.7m  | 4.0m                 |                      |
| EC Class<br><b>2</b>   | 13 mm   | standard tape  |               |  | 1.2m  | 1.6m                 |                      |
|  | 16 mm   |  |               |  | 1.5m  | 2.3m                 |                      |
|  | 19 mm   |  |               |  | 1.8m  | 2.8m                 |                      |
|  | 25 mm   |  |               |  | 2.4m<br>(10m : 2.1m)  | 3.8m<br>(10m : 3.4m) |                      |
| JIS<br><b>1</b>  | 13 mm   | standard tape  |               |  | 1.2m  | 1.6m                 |                      |
|  | 22 mm   |  |               |  | 2.1m  | 3.4m                 |                      |
| Dual Tape<br>(m/ft)  | 13 mm   | standard tape  |               |  | 1.2m  | 1.6m                 |                      |
|  | 25 mm   | Strong Tape<br> |               |  | 2.6m  | 3.9m                 |                      |
|  | 27 mm   | Strong Tape<br> |               |  | 2.7m  | 4.0m                 |                      |

Précision de mesure du ruban en acier  
Steel Tape Measurement Accuracy

|  | 2 m   | 3 m   | 5 m   | 8 m   | 10 m  |
|---|-------|-------|-------|-------|-------|
| Class 1 (mm)  | ± 0.4 | ± 0.5 | ± 0.7 | ± 1.0 | ± 1.2 |
| Class 2 (mm)  | ± 0.9 | ± 1.1 | ± 1.5 | ± 2.1 | ± 2.5 |

|  | 2 m   | 3.5 m | 5.5 m |
|---|-------|-------|-------|
| JIS 1 (mm)※   | ± 0.6 | ± 0.8 | ± 1.0 |

※Japanese Industrial Standards

# MESURES COURTES

## POCKET TAPES

01

# GS-LOCK

EXTRA STIFF

**Armored Case**  
Boîtier blindé résistant aux chocs. Protège la coque de l'impact des chutes par accident

Shock-resistant armored case protects the housing from impact during inadvertent dropping.

**Safety Rope Tether Mount With Ring**  
Évite les chutes et les pertes

Prevents dropping or mislaying.

**End Hook Guard**  
La gaine épaisse en élastomère est prolongée du corps du boîtier pour protéger le crochet en bout et la surface du ruban.

Thick elastomer case armor extends around the body of the tape measure to protect end hooks and work surfaces.

## GS-Lock

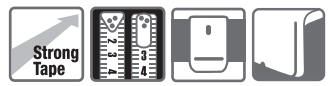

### MEASURING TAPE WITH DOUBLE METRIC AND INCH GRADUATION



| Art.Nr.         |  | Tape Measurement Accuracy | CASE | MASTER CARTON | EAN            | Weight (g) (Packaging + Product) |
|-----------------|---|---------------------------|------|---------------|----------------|----------------------------------|
| GAG3L25-50D-EUR | 25 mm   | 5.0 m/16 ft               | 6    | 30 (5 SETS)   | 4975364 122735 | 2,543 (368/pc)                   |
| GAG3L27-75D-EUR | 27 mm   | 7.5 m/25 ft               |      |               | 4975364 122742 | 3,798 (570/pc)                   |

# MESURES COURTES

## POCKET TAPES

01

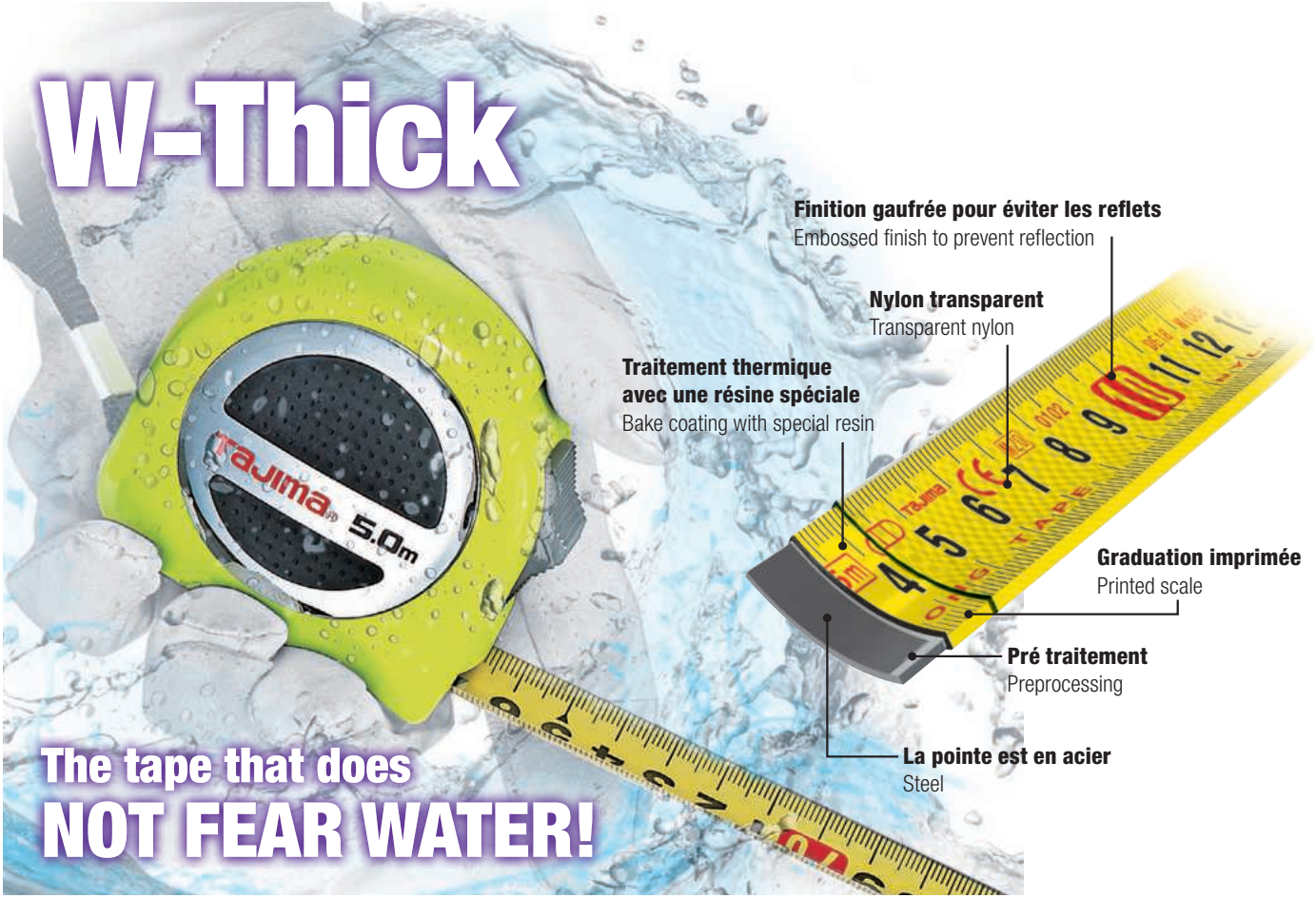

# W-Thick

The tape that does **NOT FEAR WATER!**

- Finition gaufrée pour éviter les reflets**  
Embossed finish to prevent reflection
- Nylon transparent**  
Transparent nylon
- Traitement thermique avec une résine spéciale**  
Bake coating with special resin
- Graduation imprimée**  
Printed scale
- Pré traitement**  
Preprocessing
- La pointe est en acier**  
Steel

## W-Thick



Le ressort en acier inoxydable anti-rouille; qui facilite l'enroulement. Utilisable dans l'eau et sous la pluie.

The spring is made of rust-resistant stainless, greatly improved winding problems.



### W-Thick comparaison des performances

W-Thick performance comparison

| Product                     | W-Thick                          | A                               | B                                | C                               |
|-----------------------------|----------------------------------|---------------------------------|----------------------------------|---------------------------------|
| Tape coating                | Nylon ( coating )                | Nylon ( painting )              |                                  |                                 |
| Tape length x width         | 5 m x 25 mm                      | 8 m x 25 mm                     | 5 m x 19 mm                      | 5 m x 16 mm                     |
| Tape wear resistance<br>※ 1 | <br>1,000 or more reciprocations | <br>Less than 50 reciprocations | <br>Less than 150 reciprocations | <br>Less than 50 reciprocations |
| Superior Stand-Out          | 2.3 m                            | 2.2 m                           | 2.1 m                            | 1.1 m                           |
| Rigidity ( N ) ※ 2          | Front surface                    | 8.2                             | 5.5                              | 3.9                             |
|                             | Back surface                     | 37.2                            | 26.7                             | 18.6                            |
| Hook strength ( N ) ※ 3     | 1,503                            | 586                             | 612                              | 909                             |

- ※1 They let an eraser made of sand go and back on a tape. The number indicates "how many times" an eraser did this action until the scale will be unreadable.
- ※2 This is our own/original way of showing how rigid the tape is, not will be bent or warped. The number indicates the force exactly the moment when tape snaps by being added force.
- ※3 It indicates the maximum strength of the nail by falling. It means, you drop Conve (tape sorted inside) but still the nail will not be broken.



| Art.Nr.         |              | Tape Measurement Accuracy | CASE | MASTER CARTON | EAN            | Weight ( g ) ( Packaging + Product ) |
|-----------------|--------------|---------------------------|------|---------------|----------------|--------------------------------------|
| GASP25-50EB-EUR | 25 mm    5 m | EC Class 2                | 6    | 30 ( 5 SETS ) | 4975364 122063 | 2,287 ( 358/pc )                     |

# MESURES COURTES

## POCKET TAPES

01



# Hi-LOCK



Mesure à ruban. Précision Classe 1

Class 1 premium measuring tape.

## Hi-Lock CLASS 1 16mm



## Hi-Lock CLASS 1 25mm



### Tolerance Des Mesures Ruban Acier

Steel Tape Measurement Accuracy

|      | Class 1 ( mm ) | Class 2 ( mm ) |
|------|----------------|----------------|
| 2 m  | ± 0.4          | ± 0.9          |
| 3 m  | ± 0.5          | ± 1.1          |
| 5 m  | ± 0.7          | ± 1.5          |
| 8 m  | ± 1.0          | ± 2.1          |
| 10 m | ± 1.2          | ± 2.5          |



| Art.Nr.      |       |     | Tape Measurement Accuracy | CASE | MASTER CARTON | EAN            | Weight ( g )<br>( Packaging + Product ) |
|--------------|-------|-----|---------------------------|------|---------------|----------------|---|
| L16-30E1-EUR | 16 mm | 3 m | EC Class 1                | 6    | 60            | 4975364 122056 | 128                                     |
| L25-50E1-EUR | 25 mm | 5 m |                           |      |               |                |   |

# MESURES COURTES

## POCKET TAPES

01



Auto Stop & Strong Lock

## Double Lock System



### Auto Stop

Un système auto bloquant garde le ruban sorti à la longueur requise.

It is a self blade locking system which keeps the tape stretched out at the length you need.



### Strong Lock Button

Renforce encore plus la force de fixation du ruban.

Further strengthens the fixing force of the tape.



### Retract Button

Presser le bouton par a-coups

Press the button intermittently and retract the tape.

## Sigma Stop



| Art.Nr.        |       |     | Tape Measurement Accuracy | CASE | MASTER CARTON | EAN            | Weight (g) (Packaging + Product) |
|----------------|-------|-----|---------------------------|------|---------------|----------------|----------------------------------|
| SSS16-30EB-EUR | 16 mm | 3 m | EC Class 2                | 6    | 30 ( 5 SETS ) | 4975364 125835 | 190                              |
| SSS19-50EB-EUR | 19 mm | 5 m |                           |      |               | 4975364 125842 | 274                              |

# MESURES COURTES

## POCKET TAPES

# W-MAG

La seule mesure à semelle et crochet terminal magnétiques pouvant être utilisée par une seule personne pour la plomberie, la construction de charpente métallique et la pose de cloisons sèches.

Unique magnetic base tape measures with magnetic end hooks designed for fast one-person measurements in plumbing, steel stud framing, and metal fabrication applications.

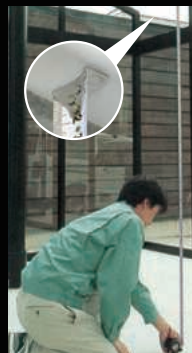

image

## W-MAG



More info



| Art.Nr.           |  | Tape Measurement Accuracy | CASE | MASTER CARTON | EAN            | Weight (g) (Packaging + Product) |
|-------------------|---|---------------------------|------|---------------|----------------|----------------------------------|
| G3GLWM25-50EB-EUR | 25 mm    5 m  | EC Class 2                | 6    | 30 ( 5 SETS ) | 4975364 120366 | 2,344 ( 358/pc )                 |

# MESURES COURTES

## POCKET TAPES

01

### W-MAG Safety Belt Holder



Pour mesurer rapidement avec une seule main Permet un accrochage/décrochage à une main

The quick-fit belt holder enables you to attach & detach the housing on the holder with one hand.



| Art.Nr.            |  | Tape Measurement Accuracy | CASE | MASTER CARTON | EAN            | Weight (g) (Packaging + Product) |
|--------------------|---|---------------------------|------|---------------|----------------|----------------------------------|
| SFG3GLWM2570EB-EUR | 25 mm   7 m   | EC Class 2                | 6    | 24 ( 4 SETS ) | 4975364 125828 | 3,496 ( 551/pc )                 |

### Safety Belt Holder



- Permet l'accrochage et le décrochage d'une seule main.
- Prévient les chutes et la perte
- Allows one-handed hooking/unhooking
- Prevents from dropping or mislaying

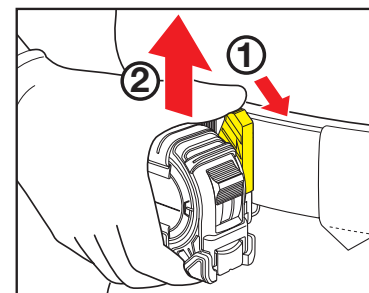

- ① **Bouton Appuyer et maintenir**  
Press & Hold Button
- ② **Soulever**  
Lift up

#### Wearable Adjustable Belt Sizes

Up to 60 mm wide  
Up to 5.5 mm thick

| Art.Nr.     | CASE | MASTER CARTON | EAN            | Weight (g) (Packaging + Product) |
|-------------|------|---------------|----------------|----------------------------------|
| SF-BHLD-EUR | 6    | 60            | 4975364 122780 | 42                               |

# MESURES COURTES

## POCKET TAPES

# G<sup>3</sup>-LOCK

Mesures de haute qualité pour les usages exigeant une rigidité supérieure, fixation magnétique du ruban et graduations précises recto/verso.

Premium tape measures designed for applications requiring superior stand-out, magnetic tape attachment and accurate scale readability from either side of the tape.



### Strong Tape

Ruban en acier plus épais offrant une meilleure rigidité que les mesures classiques.

Extra thick steel generates more stiffness than standard tape measures.



## G3-Lock



### CONVEX-SET1

- G3-Lock 27mm 5 m
- Dorafin Quick Back
- Razar Black Blade



| Art.Nr.          |  | Tape Measurement Accuracy | CASE | MASTER CARTON | EAN            | Weight (g) (Packaging + Product) |                  |
|------------------|---|---------------------------|------|---------------|----------------|----------------------------------|------------------|
| G3GLM27-50EB-EUR | 27 mm   | 5 m                       | 6    | 30 ( 5 SETS ) | 4975364 029782 | 2,544 ( 392/pc )                 |                  |
| G3GLM27-80EB-EUR |   | 8 m                       |      |               | EC Class 2     | 4975364 029973                   | 3,710 ( 585/pc ) |
| CONVEX-SET1      |   | 5 m                       |      |               |                | 4975364 076168                   | 4,004 ( 620/pc ) |

# MESURES COURTES

## POCKET TAPES

01

# Z-LOCK

### Grip Elastomere Antidérapant

Non-Slip Elastomer Grip



### Système D'absorption De Choc Au Niveau Du Crochet

Hook Guard Bumper



### Frein De Controle

Sert à réguler la vitesse de rentrée du ruban dans le boîtier.

Recoil Brake

to safely control recoil speed.

### Strong Tape

Ruban en acier plus épais offrant une meilleure rigidité que les mesures classiques.

Extra thick steel generates more stiffness than standard tape measures.

## Z-LOCK



| Art.Nr.       |  | Tape Measurement Accuracy | CASE | MASTER CARTON | EAN            | Weight (g) (Packaging + Product) |
|---------------|---|---------------------------|------|---------------|----------------|----------------------------------|
| ZL25-50EB-EUR | 25 mm   | 5 m                       | 6    | 30 (5 SETS)   | 4975364 120922 | 2,340 (358/pc)                   |
| ZL25-80EB-EUR |   | 8 m                       |      |               | EC Class 2     | 4975364 120939                   |

# MESURES COURTES

## POCKET TAPES

01

# G-LOCK



**Grip Elastomère Antidérapant**  
Non-Slip Elastomer Grip

**Système D'absorption De Choc Au Niveau Du Crochet**  
Hook Guard Bumper

**3x crochets d'extrémité de rivet**  
Strong Triple Riveted End Hook



**Shock Resistant**

**Résistant aux chutes, pas de rayures sur la finition de la surface même en cas de chute**  
Drop-resistant, so no scratches on surface finish even if dropped

## G-LOCK



**G Lock Pyramid**  
G Lock Pyramid Set



**GLPYR-SET2**      **GLPYR-SET3**  
• G-LOCK 25mm 5 m x 16      • G-LOCK 25mm 5 m x 24  
• G-LOCK 25mm 7 m x 8

| Art.Nr.        | Tape Measurement Accuracy |     | CASE | MASTER CARTON | EAN            | Weight (g) (Packaging + Product) |
|----------------|---------------------------|-----|------|---------------|----------------|----------------------------------|
| GL16-30E -EUR  | 16 mm                     | 3 m | 6    | 60            | 4975364 026552 | 154                              |
| GL19-50EB -EUR | 19 mm                     | 5 m |      | 30 (5 SETS)   | 4975364 024800 | 1,798 (268/pc)                   |
| GL25-50EB -EUR | 25 mm                     | 5 m |      | 30 (5 SETS)   | 4975364 024695 | 2,092 (316/pc)                   |
| GL25-70EB -EUR |                           | 7 m |      | 30 (5 SETS)   | 4975364 024718 | 2,868 (446/pc)                   |

| Art.Nr.         | Tape Measurement Accuracy |                | CASE | MASTER CARTON | EAN            | Weight (g) (Packaging + Product) |
|-----------------|---------------------------|----------------|------|---------------|----------------|----------------------------------|
| GL25-80EB -EUR  | 25 mm                     | 8 m            | 6    | 30 (5 SETS)   | 4975364 026705 | 3,178 (497/pc)                   |
| GL25-100EB -EUR |                           | 10 m           |      |               | 4975364 025296 | 3,818 (603/pc)                   |
| GLPYR-SET2      |                           | 5 m 7 m        | 24   | 48            | 4975364 026101 | 8,050                            |
| GLPYR-SET3      | 5 m                       | 4975364 120595 |      |               | 7,050          |                                  |

# MESURES COURTES

## POCKET TAPES

01

### G-Lock Dual graduation ( m/ft )

MEASURING TAPE WITH DOUBLE METRIC AND INCH GRADUATION



| Art.Nr.       |  | Tape Measurement Accuracy | CASE | MASTER CARTON | EAN            | Weight ( g ) ( Packaging + Product ) |
|---------------|---|---------------------------|------|---------------|----------------|--------------------------------------|
| GL25-50D-EUR  | 25 mm   | 5 m/16 ft                 | 6    | 30 ( 5 SETS ) | 4975364 122759 | 2,237 ( 317/pc )                     |
| GL25-75D-EUR  |   | 7.5 m/25 ft               |      |               | 4975364 122766 | 3,162 ( 470/pc )                     |
| GL25-100D-EUR |   | 10 m/33 ft                |      |               | 4975364 122773 | 3,903 ( 583/pc )                     |

### Magnet-G



Mesure résistante aux chocs à crochet terminal magnétique. Système d'absorption de choc. Boîtier renforcé.

Shock resistant measuring tapes with magnetic end hooks and cushioned end hook returns, in armored cases.



| Art.Nr.        |  | Tape Measurement Accuracy | CASE | MASTER CARTON | EAN            | Weight ( g ) ( Packaging + Product ) |
|----------------|---|---------------------------|------|---------------|----------------|--------------------------------------|
| GLM25-50EB-EUR | 25 mm   | 5 m                       | 6    | 30 ( 5 SETS ) | 4975364 028426 | 2,092 ( 316/pc )                     |

# MESURES COURTES

## POCKET TAPES

01

# Hi-LOCK



**Mesure fine et fiable, boîtier ABS compact et ergonomique.**

Smooth and dependable measuring tapes in compact and ergonomic ABS cases.

## Hi-Lock



| Art.Nr.      |  |      | Tape Measurement Accuracy | CASE | MASTER CARTON | EAN            | Weight (g) (Packaging + Product) |
|--------------|---|------|---------------------------|------|---------------|----------------|----------------------------------|
| L16-30E-EUR  | 16 mm   | 3 m  | EC Class 2                | 6    | 60            | 4975364 010742 | 132                              |
| L16-50E-EUR  |   |      |                           |      |               | 4975364 010803 | 201                              |
| L19-50EB-EUR | 19 mm   | 5 m  |                           |      | 48 (8 SETS)   | 4975364 011077 | 1,594 (234/pc)                   |
| L25-50EB-EUR | 25 mm   |      |                           |      | 48 (8 SETS)   | 4975364 011350 | 1,902 (285/pc)                   |
| L25-70EB-EUR |   | 7 m  |                           |      | 48 (8 SETS)   | 4975364 011398 | 2,562 (395/pc)                   |
| L25-100E-EUR |   | 10 m |                           |      | 30            | 4975364 024220 | 542                              |

# MESURES COURTES

## POCKET TAPES

01

### Top-Conve

#### Belt Clip Type



Mesure avec arrêt automatique original Tajima qui maintient automatiquement le ruban sorti.

Tajima's original Auto Stop measuring tapes that automatically hold the tape at any extension.

| Art.Nr.        |  | Tape Measurement Accuracy | CASE       | MASTER CARTON | EAN | Weight (g) (Packaging + Product) |     |
|----------------|---|---------------------------|------------|---------------|-----|----------------------------------|-----|
| TOP13-20EK-EUR | 13 mm   | 2 m                       | EC Class 2 | 6             | 120 | 4975364 011558                   | 86  |
| TOP13-30EK-EUR |   | 3 m                       |            |               |     | 4975364 011596                   | 121 |
| TOP13-35EK-EUR |   | 3.5 m                     |            |               | 60  | 4975364 011626                   | 134 |
| TOP13-50EK-EUR |   | 5 m                       |            |               |     | 4975364 011664                   | 166 |

### Top-Conve



Mesure avec arrêt automatique original Tajima qui maintient automatiquement le ruban sorti.

Tajima's original Auto Stop measuring tapes that automatically hold the tape at any extension.

Précision de mesure du ruban en acier  
Steel Tape Measurement Accuracy

|  | JIS 1 (mm) |
|---|------------|
| 2 m   | ± 0.6      |
| 3.5 m   | ± 0.8      |
| 5.5 m   | ± 1.0      |

| Art.Nr.       |  | Tape Measurement Accuracy | CASE | MASTER CARTON | EAN | Weight (g) (Packaging + Product) |     |
|---------------|---|---------------------------|------|---------------|-----|----------------------------------|-----|
| TOP13-20N-EUR | 13 mm   | 2 m                       | JIS  | 6             | 120 | 4975364 025111                   | 82  |
| TOP13-35N-EUR |   | 3.5 m                     |      |               |     | 4975364 025128                   | 127 |
| TOP13-55N-EUR |   | 5.5 m                     |      |               | 60  | 4975364 025135                   | 173 |

### Hi-Conve



Mesure ergonomique d'utilisation facile et garantissant un rembobinage souple et stable.

Ergonomic measuring tapes fit comfortably in hand, deliver smooth and consistent rewind.

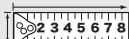
| Art.Nr.      |  | Tape Measurement Accuracy | CASE       | MASTER CARTON | EAN | Weight (g) (Packaging + Product) |    |
|--------------|---|---------------------------|------------|---------------|-----|----------------------------------|----|
| H13-20EN-EUR | 13 mm   | 2 m                       | EC Class 2 | 6             | 120 | 4975364 125712                   | 77 |

# MESURES COURTES

## POCKET TAPES

01

### My-Conve



#### MEASURING TAPE WITH DOUBLE METRIC AND INCH GRADUATION

Mesure de forme rectangulaire avec arrêt automatique Tajima qui maintient automatiquement le ruban sorti.

Rectangular-shaped measuring tapes with Tajima's Auto Stop that automatically holds the tape at any extension.

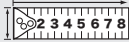

| Art.Nr.       |  |            | Tape Measurement Accuracy | CASE | MASTER CARTON | EAN            | Weight (g) (Packaging + Product) |
|---------------|---|------------|---------------------------|------|---------------|----------------|----------------------------------|
|               | 13 mm   | 2 m / 6 ft |                           |      |               |                |                                  |
| NMY13-20D-EUR | 13 mm   | 2 m / 6 ft | —                         | 6    | 120           | 4975364 011718 | 92                               |

### Pit-Measure

Ruban adhésif.

Adhesive-backed measuring tapes.

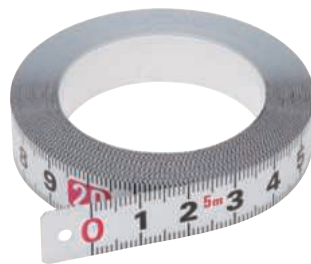

Right base point ( PIT-30FRC-EUR )

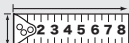
| Art.Nr.       |  |                       | Tape Measurement Accuracy | CASE | MASTER CARTON | EAN            | Weight (g) (Packaging + Product) |
|---------------|---|-----------------------|---------------------------|------|---------------|----------------|----------------------------------|
|               | 13 mm   | 1 m / 2 m / 5 m / 3 m |                           |      |               |                |                                  |
| PIT-10C-EUR   | 13 mm   | 1 m                   | —                         | 6    | 120           | 4975364 125781 | 27                               |
| PIT-20C-EUR   |   | 2 m                   |                           |      |               | 4975364 125798 | 43                               |
| PIT-50C-EUR   |   | 5 m                   |                           |      |               | 4975364 125804 | 85                               |
| PIT-30FRC-EUR |   | 3 m                   |                           |      |               | 4975364 122216 | 56                               |

# MESURE AU LASER

## LASER DISTANCE METER

02



### Fonctionnement simple, résultats précis

Mesure rapidement les distances et calcule la surface, le volume et pythagore.

### Simple Operation, Precise Results

Quickly measures distances and computes total area, volume, more.

Laser Distance Meter

# F05

## Laser Distance Meter F05



Options Début  
Starting Point Options

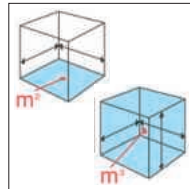

Calcul surface ou volume  
Compute total area or volume

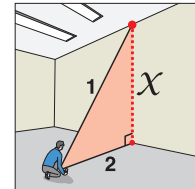

Pythagore  
Pythagoras

2 ou 3 points pour le calcul Pythagore.

Two or three point pythagoras.

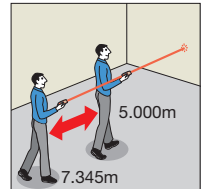

Mesure en continu  
Continuous Measuring

Accessoires  
- Etui  
- 2 piles AAA

Accessories  
- Protective Case  
- Two AAA batteries

| Art.Nr.  | Measurement range | TOLERANCE ACCURACY | CASE | MASTER CARTON | EAN            | Weight ( g ) ( Packaging + Product ) |
|----------|-------------------|--------------------|------|---------------|----------------|--------------------------------------|
| LKT-F05R | 0.05 m – 50 m     | ± 2.0 mm           | -    | 10            | 4975364 048660 | 239                                  |

## Laser Distance Meter F02



Options Début  
Starting Point Options

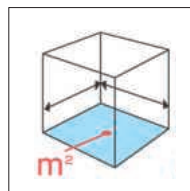
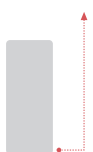

Calcul surface  
Compute total area

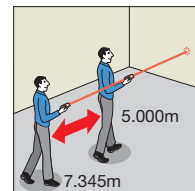

Mesure en continu  
Continuous Measuring



Léger et compact  
Lightweight and Compact

Accessoires  
- Etui  
- 2 piles AAA

Accessories  
- Pouch  
- Two AAA batteries

| Art.Nr.  | Measurement range | TOLERANCE ACCURACY | CASE | MASTER CARTON | EAN            | Weight ( g ) ( Packaging + Product ) |
|----------|-------------------|--------------------|------|---------------|----------------|--------------------------------------|
| LKT-F02R | 0.2 m – 20 m      | ± 3.0 mm           | -    | 10            | 4975364 048646 | 183                                  |

# MESURES LONGUES

## LONG TAPES

# Engineer

03



### TYPE DE RUBANS TAPE CALIBRATION

| Image                  | Image                                      | Image | Disponible Available for |
|------------------------|--|-------|--------------------------|
|                        |  |       | <b>ENGINEER POCKET</b>   |
| <b>10 mm (0.18 mm)</b> | ruban revêtu acrylique blanc               |       | <b>ENGINEER POCKET</b>   |
| <b>13 mm (0.23 mm)</b> | White polyester-blend coated tape          |       | <b>ENGINEER TEN</b>      |
| <b>10 mm (0.44 mm)</b> | ruban recouvert nylon<br>Nylon coated tape |       | <b>ENGINEER SUPER</b>    |

### TYPES DE POINTS ZERO TYPES OF ZERO-POINTS

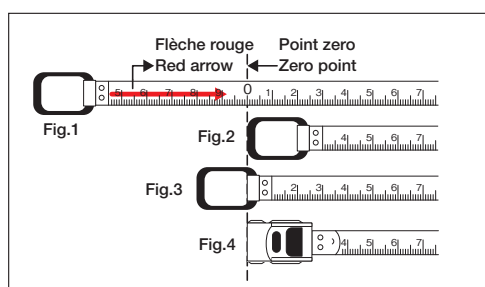

### STUCTURE DES RUBANS TAPE COMPOSITION

**RUBAN AVEC REVÊTEMENT ACRYLIQUE BLANC**  
Un revêtement en mélange de polyester protège le ruban et améliore sa rigidité.

- ① noyau en acier haut de gamme
- ② traitement de surface
- ③ impression précise longue durée
- ④ revêtement hyper-résistant de la surface en résine acrylique

**WHITE POLYESTER-BLEND COATED TAPE**  
Polyester-blend coating protects the tape and improves tape stand-out.

- ① High grade tool steel core
- ② Surface treatment
- ③ Accurate, long lasting printing
- ④ Tough, polyester-blend coating



**RUBAN AVEC REVÊTEMENT NYLON**  
Un revêtement de nylon résistant est appliqué sur le ruban en mélange de polyester et le rend résistant à la rouille et aux rayure tout en améliorant sa rigidité.

- ① noyau en acier haut de gamme
- ② traitement de surface
- ③ revêtement hyper-résistant de la surface en résine acrylique
- ④ impression précise longue durée
- ⑤ revêtement de la surface en nylon clair
- ⑥ Finition grénée anti reflets.

**NYLON COATED STEEL TAPES**  
A tough nylon coating is applied on top of the polyester-blend coated tape making it rust and scratch resistant and improving tape stand-out.

- ① High grade tool steel core
- ② Surface treatment
- ③ Tough, polyester-blend coating
- ④ Accurate, long lasting printing
- ⑤ Clear nylon coating
- ⑥ Embossed finish reduces glare

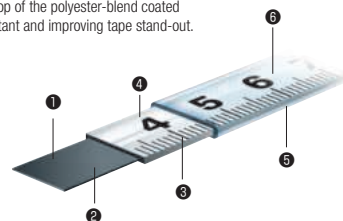

# MESURES LONGUES

## LONG TAPES



### Engineer Ten



Mesure d'arpentage, boîtier ajouré, ruban acier, mécanisme souple et fiable. Pour des mesures précises.

Smooth and dependable open-reel steel tape measures designed for accurate long-distance measuring.

03

| Art.Nr.     |  |  | Tape Measurement Accuracy | CASE        | MASTER CARTON | EAN | Weight ( g ) ( Packaging + Product ) |
|-------------|---|---|---------------------------|-------------|---------------|-----|--------------------------------------|
| HTN30MW2A01 | 13 mm   | 30 m  | Fig.2                     | JIS         | -             | 10  | 1,074                                |
| HTN30MW3A10 |   |   | Fig.3                     | No class EC |               |     |                                      |
| HTN50MW2A01 |   | 50 m  | Fig.2                     | JIS         |               |     | 4975364 042064                       |
| HTN50MW3A10 |   |   | Fig.3                     | No class EC |               |     | 4975364 037381                       |

### Engineer Super



Mesure d'arpentage de haut de gamme, boîtier ajouré. Ruban acier large, revêtu de nylon pour résister à l'eau et aux produits chimiques.

Premium open-reel steel tape measures with 10 mm wide nylon coated tapes that resist damage from water or jobsite chemicals.

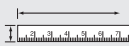
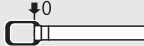
| Art.Nr.     |  |  | Tape Measurement Accuracy | CASE | MASTER CARTON | EAN            | Weight ( g ) ( Packaging + Product ) |
|-------------|---|---|---------------------------|------|---------------|----------------|--------------------------------------|
| HSP30MW3A10 | 10 mm   | 30 m  | Fig.3                     | -    | 10            | 4975364 037220 | 835                                  |
| HSP50MW3A10 |   | 50 m  |                           |      |               | 4975364 037282 | 1,138                                |

# MESURES LONGUES

## LONG TAPES



### Engineer Pocket

03

Mesure longue, ruban acier, mécanisme robuste, boîtier léger en ABS.

Strong closed-reel steel tape measures in lightweight yet durable ABS cases.



| Art.Nr.     |  |  | Tape Measurement Accuracy | CASE        | MASTER CARTON | EAN | Weight ( g )<br>( Packaging + Product ) |                |     |                |
|-------------|---|---|---------------------------|-------------|---------------|-----|---|----------------|-----|----------------|
| EPK10MW1E01 | 10 mm   | 10m   | Fig.1                     | JIS         | 4             | 40  | 195                                     |                |     |                |
| EPK10MW2E01 |   |   | Fig.2                     | JIS         |               |     |   | -              |     |                |
| EPK10MW3E10 |   |   | Fig.3                     | No class EC |               |     |   | 4975364 037053 |     |                |
| EPK10MW4E01 |   |   | Fig.4                     | JIS         |               |     |   | -              |     |                |
| EPK20MW1E01 |   | 20m   | Fig.1                     | JIS         |               |     | 4                                       | 40             | 316 |                |
| EPK20MW2E01 |   |   | Fig.2                     | JIS         |               |     |   |                |     | -              |
| EPK20MW3E10 |   |   | Fig.3                     | No class EC |               |     |   |                |     | 4975364 037107 |
| EPK20MW4E01 |   |   | Fig.4                     | JIS         |               |     |   |                |     | 4975364 012579 |
| EPK30MW1E10 |   | 30m   | Fig.1                     | No class EC |               |     | 4                                       | 40             | 440 |                |
| EPK30MW3E10 |   |   | Fig.3                     | No class EC |               |     |   |                |     | 4975364 037152 |
| EPK30MW4E01 |   |   | Fig.4                     | JIS         |               |     |   |                |     | 4975364 037169 |
| EPK30MW4E01 |   |   |                           |             |               |     |   |                |     |                |

# MESURES LONGUES

## LONG TAPES

# Symron

03



### TYPE DE RUBANS TAPE CALIBRATION

|                        |                  |            | Available for   |
|------------------------|------------------|------------|---|
| <b>13 mm (0.52 mm)</b> | Metric (2mm/5mm) | JIS        | <b>SYMRON-L</b><br><b>SYMRON-R</b><br><b>SYMRON-S</b> |
|                        | Metric (EC)      | EC Class 3 |   |

### STRUCTURE DES RUBANS TAPE COMPOSITION

**Rubans en verre de fibre**  
Caractéristiques des rubans en fibre de verre revêtus de PVC.

- ① Brins en fibre de verre
- ② peinture spéciale en résine
- ③ graduation imprimée avec précision
- ④ Revêtement en PVC transparent
- ⑤ Finition grénee anti reflets.

Symron fiberglass tapes  
Characteristics of PVC-coated fiberglass tape.

- ① Fiberglass strands througho
- ② Special resin paint
- ③ Accurate printed scales
- ④ Transparent PVC coating
- ⑤ Embossed finish reduces gl

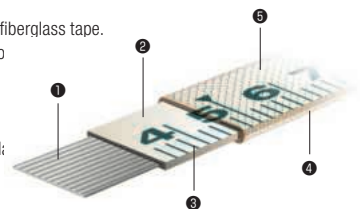

### TYPES DE POINTS ZERO TYPES OF ZERO-POINTS

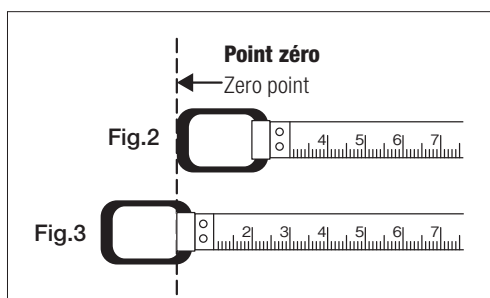

● Seules les figures 3 sont conformes au règlement classe 3 de l'UE.

● Fig. 3 Zero Point conform to EC Class 3 regulations

**Les rubans Symron en fibre de verre de Tajima n'ont aucune conductivité électrique et possèdent un revêtement de la surface en PVC transparent. Ce revêtement spécial rend les rubans Tajima 100 fois plus résistants à l'usure que des rubans en fibre de verre sans revêtement.**

Tajima Symron Fiberglass Tapes are electrically non-conductive and feature a transparent PVC coating. This special coating makes Tajima tapes over 100 times more resistant to wear. White / Yellow color coding aids scale identification and helps prevent tape twist during rewind.

# MESURES LONGUES

## LONG TAPES

### Symron-L

Mesure longue en fibre de verre, boîtier ajouré, revêtement de protection en PVC.

Semi closed-reel fiberglass tape measures with protective PVC tape coatings.



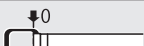

| Art.Nr.      |  |  | Tape Measurement Accuracy | CASE       | MASTER CARTON | EAN | Weight ( g ) ( Packaging + Product ) |     |
|--------------|--|--|---------------------------|------------|---------------|-----|--------------------------------------|-----|
| SYL30MTBG01E | 13 mm  | 30 m   | Fig.2                     | JIS        | 4             | 12  | 4975364 034892                       | 575 |
| SYL50MT3G15  |  | 50 m   | Fig.3                     | EC Class 3 |               |     | 4975364 034908                       | 835 |

### Symron-R

Mesure d'arpentage en fibre de verre, revêtement de protection en PVC.

Open-reel fiberglass tape measures with protective PVC tape coatings.



| Art.Nr.        |  |  | Tape Measurement Accuracy | CASE | MASTER CARTON | EAN            | Weight ( g ) ( Packaging + Product ) |
|----------------|---|---|---------------------------|------|---------------|----------------|--------------------------------------|
| SYR30MT3G15    | 13 mm   | 30 m  | Fig.3                     | 4    | 12            | 4975364 034915 | 560                                  |
| SYR50MT3U15TAG |   | 50 m  |                           |      |               | -              | 820                                  |

# MESURES LONGUES

## LONG TAPES

### Symron-S

Mesure longue en fibre de verre, boîtier fermé, revêtement de protection PVC.

Closed-reel fiberglass tape measures with protective PVC tape coatings.

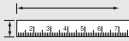
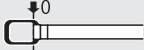

03

| Art.Nr.        |  |  | Tape Measurement Accuracy | CASE       | MASTER CARTON | EAN | Weight ( g ) ( Packaging + Product ) |     |
|----------------|---|---|---------------------------|------------|---------------|-----|--------------------------------------|-----|
| SYS20MT2E01E   | 13 mm   | 20 m  | Fig.2                     | JIS        | 4             | 24  | 4975364 035059                       | 380 |
| SYS20MT3U15TAG |   | 20 m  | Fig.3                     | EC Class 3 | 4             | 24  | -                                    | 380 |
| SYS50MT3B15    |   | 50 m  |                           |            | -             | 10  | 4975364 035073                       | 745 |

# LAMES DE RECHANGE POUR CUTTERS

## CUTTER KNIFE BLADES

04

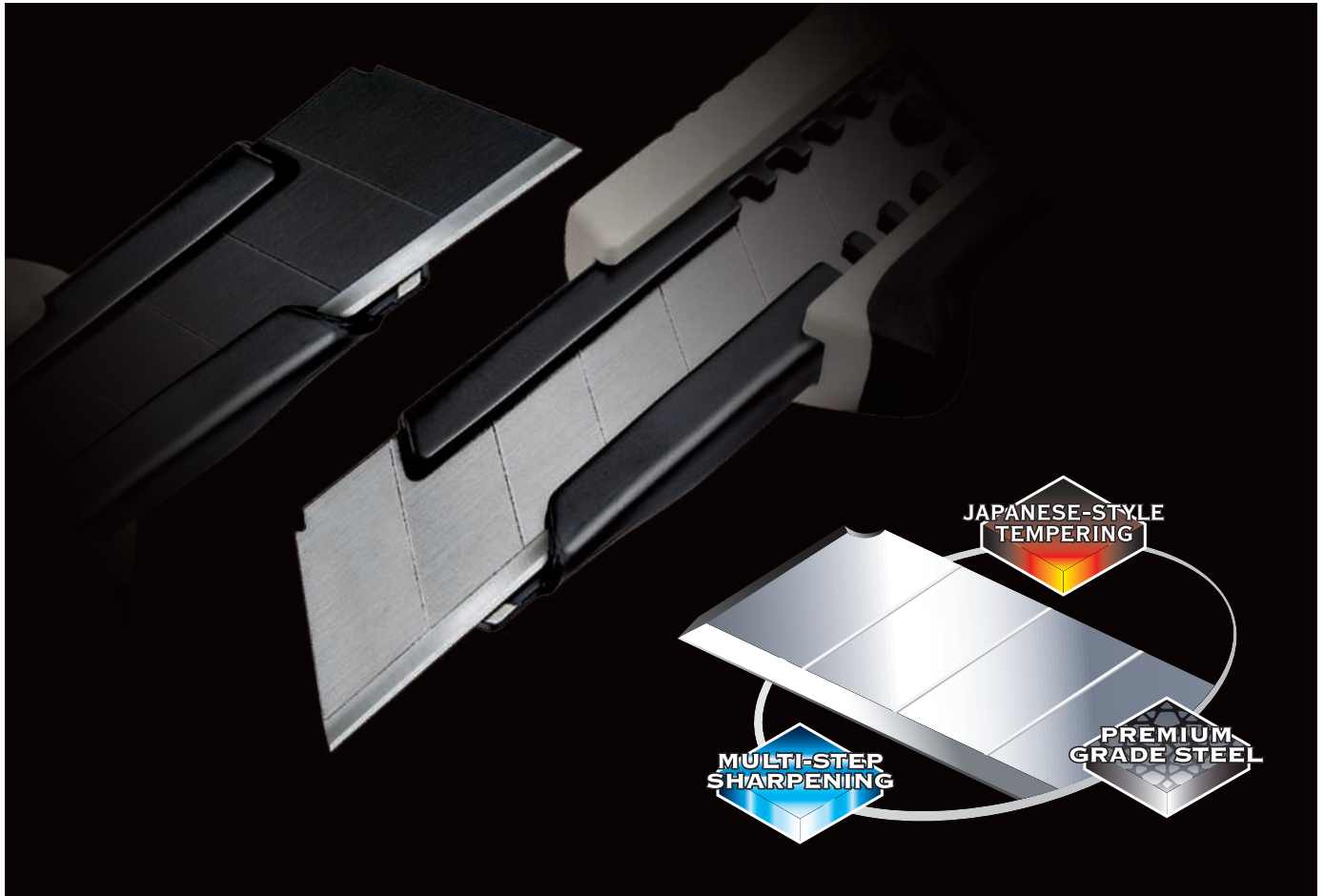

L'acier le plus haut de gamme qui garantit une résistance exceptionnelle et permet un usinage et un affûtage plus précis.

The purest grade of steel ensures the strongest-possible core and results in a more accurately tooled and sharpened blade.



Une expérience séculaire dans le traitement thermique de l'acier pour obtenir une plus grande dureté et un affûtage longue durée.

A centuries-old process of heat-treating and hardening the steel to further maximize blade strength and cutting edge life.



Une géométrie du tranchant optimisée associée à une technique de pointe dans l'affûtage offrent des performances de coupe exceptionnelles.

Optimized cutting edge geometry and advanced honing techniques results in consistent, superior cutting performance.

# LAMES DE RECHANGE POUR CUTTERS

## CUTTER KNIFE BLADES

High durability



### Endura-Blade

Usage universel pour marquer ou couper des matériaux épais tels que bois ou cloisons sèches. Une lame extrêmement affûtée et résistante qui combine acier de qualité supérieure, technique japonaise de trempe et affûtage en plusieurs étapes pour offrir longé

For general purpose scoring and cutting, ideal for work with Drywall, Wood and other Thick Materials. An extremely sharp and strong blade that integrates premium steel, Japanese-style tempering and multi-step sharpening to produce a dependable, solid feel and long cutting performance.

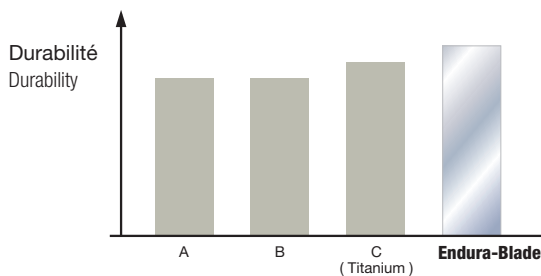

Sharpness



### Razar Black Blade

Pour la coupe précise de matières fines, idéal pour travailler sur papier, film ou autres matières de faible épaisseur. Une lame coupante comme une lame de rasoir qui combine acier de qualité supérieure, technique japonaise de trempe en affûtage en plusieu

For precise cutting and fine material slicing, ideal for work with Paper, Film and other Thin Materials. A razor-sharp acute angle blade that integrates premium steel, Japanese-style tempering and multi-step sharpening to produce an exceptionally smooth and fine quality of cut.

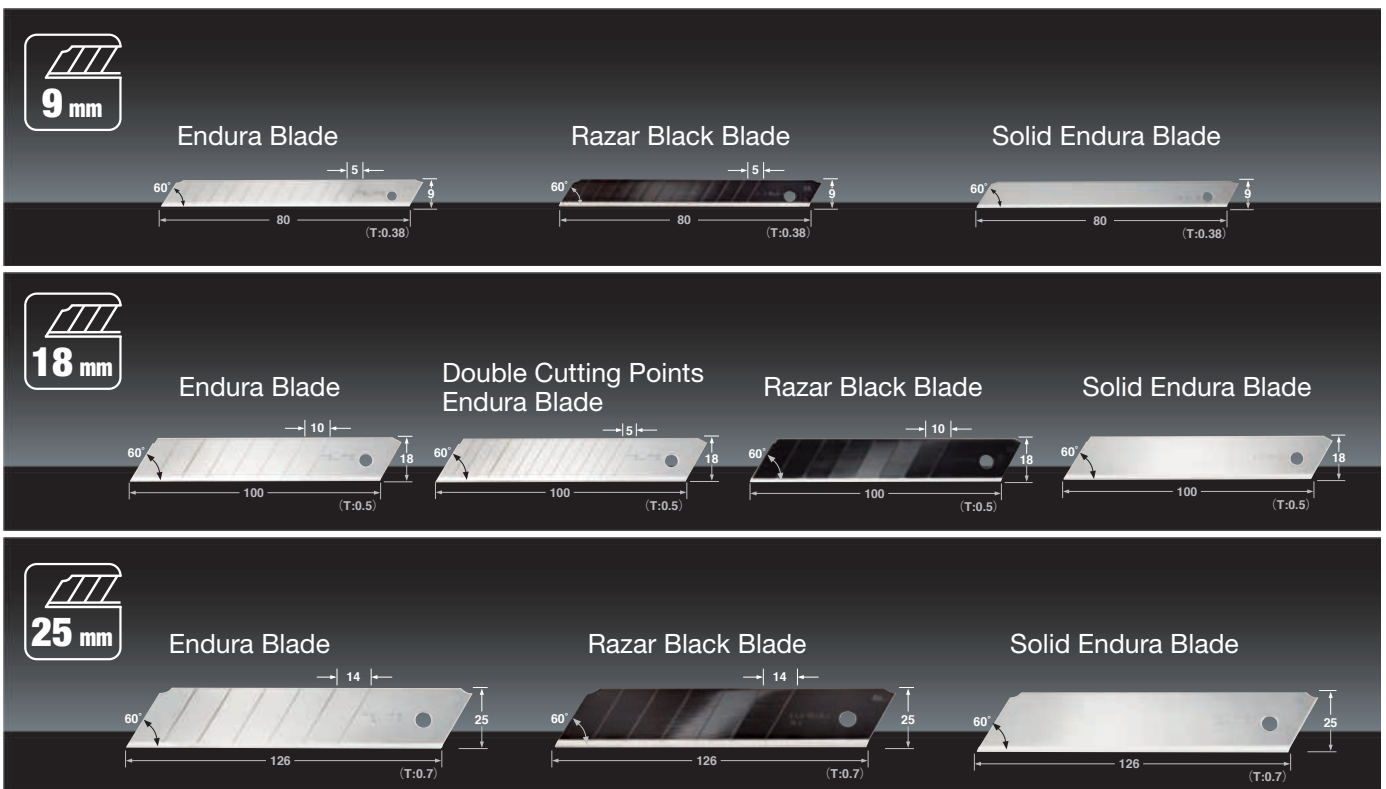
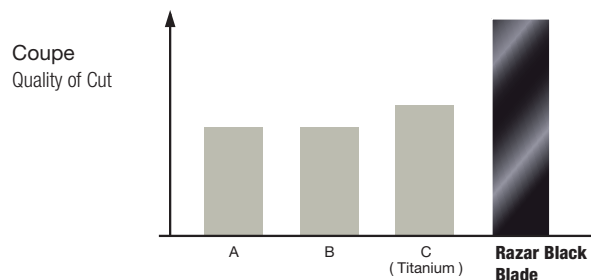

# LAMES DE RECHANGE POUR CUTTERS

## CUTTER KNIFE BLADES

### 9mm Endura Blade



(T:0.38)

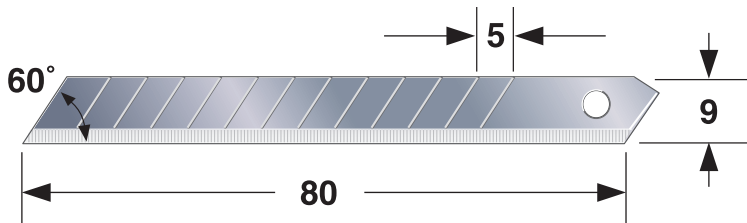

①



②



③



| Art.Nr.     |    | CASE (  ) | MASTER CARTON (  ) | EAN            | Weight ( g )<br>( Packaging + Product ) |
|-------------|----|-----------|--------------------|----------------|---|
| ① LB30N/-1  | 10 | 10 (100)  | 120 (1,200)        | 4975364 051561 | 22                                      |
| ② LCB30C/Y1 | 10 | 10 (100)  | 120 (1,200)        | 4975364 014252 | 25                                      |
| ③ EA-50HC   | 50 | 10 (500)  | 100 (5,000)        | 4975364 113436 | 110                                     |

### 9mm Razar Black Blade



(T:0.38)

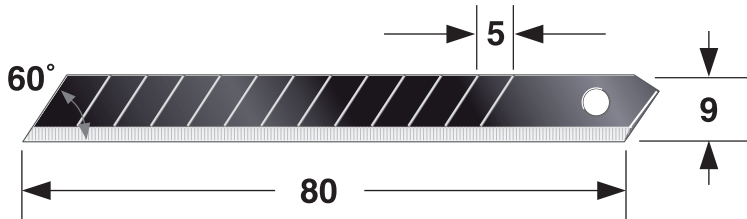

①



②



| Art.Nr.       |    | CASE (  ) | MASTER CARTON (  ) | EAN            | Weight ( g )<br>( Packaging + Product ) |
|---------------|----|-----------|--------------------|----------------|---|
| ① LCB30RBC/K1 | 10 | 10 (100)  | 120 (1,200)        | 4975364 111050 | 25                                      |
| ② RBA-50HC    | 50 | 10 (500)  | 100 (5,000)        | 4975364 113450 | 110                                     |

### 9mm Solid Endura Blade



(T:0.38)

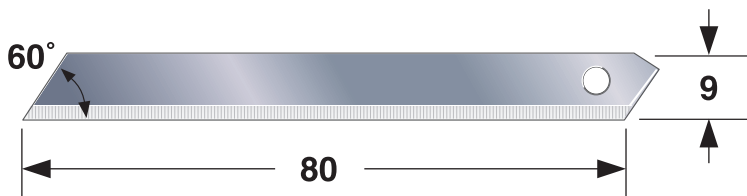

| Art.Nr.    |    | CASE (  ) | MASTER CARTON (  ) | EAN            | Weight ( g )<br>( Packaging + Product ) |
|------------|----|-----------|--------------------|----------------|---|
| LCB30SC/Y1 | 10 | 10 (100)  | 120 (1,200)        | 4975364 018984 | 25                                      |

# LAMES DE RECHANGE POUR CUTTERS

## CUTTER KNIFE BLADES

### 18mm Endura Blade



(T:0.5)

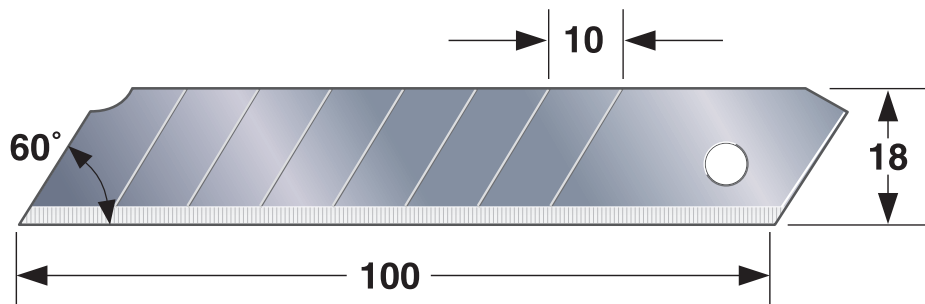

①





②



③







| Art.Nr.     |  | CASE (  ) | MASTER CARTON (  ) | EAN            | Weight (g)<br>( Packaging + Product ) |
|-------------|---|--|--|----------------|---------------------------------------|
| ① LB50N/-1  | 10  | 10 (100)   | 120 (1,200)  | 4975364 021571 | 62                                    |
| ② LCB50C/Y1 | 10  | 10 (100)   | 120 (1,200)  | 4975364 014276 | 80                                    |
| ③ EL-50HC   | 50  | 10 (500)   | 50 (2,500)   | 4975364 113467 | 362                                   |

### 18mm Solid Endura Blade

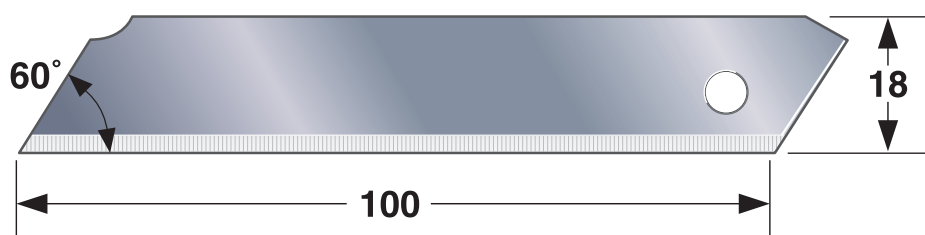

(T:0.5)







| Art.Nr.    |  | CASE (  ) | MASTER CARTON (  ) | EAN            | Weight (g)<br>( Packaging + Product ) |
|------------|---|--|--|----------------|---------------------------------------|
| LCB50SN/YE | 10  | 10 (100)   | 120 (1,200)  | 4975364 019059 | 80                                    |

### 18mm Double Segment Endura Blade

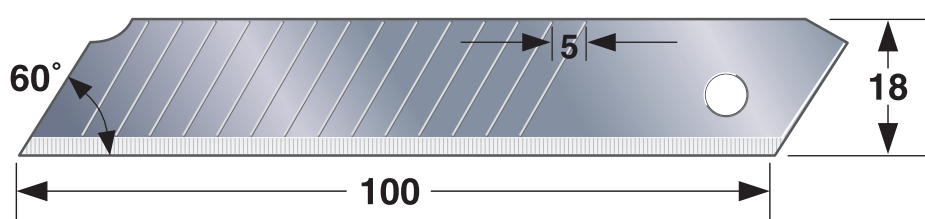

(T:0.5)



| Art.Nr.    |  | CASE (  ) | MASTER CARTON (  ) | EAN           | Weight (g)<br>( Packaging + Product ) |
|------------|---|--|--|---------------|---------------------------------------|
| LCB50DC/Y1 | 10  | 10 (100)   | 120 (1,200)  | 4975364041357 | 80                                    |

# LAMES DE RECHANGE POUR CUTTERS

## CUTTER KNIFE BLADES

### 18mm Razar Black Blade



(T:0.5)

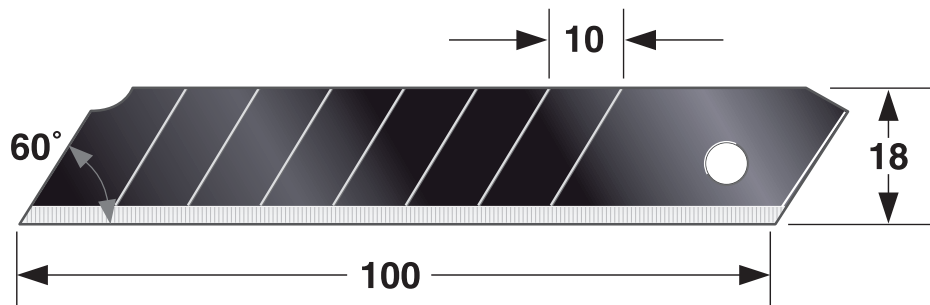

①



②



| Art.Nr.       |    | CASE (  ) | MASTER CARTON (  ) | EAN            | Weight ( g )<br>( Packaging + Product ) |
|---------------|----|-----------|--------------------|----------------|---|
| ① LCB50RBC/K1 | 10 | 10 (100)  | 120 (1,200)        | 4975364 019042 | 80                                      |
| ② RBL-50HC    | 50 | 10 (500)  | 50 (2,500)         | 4975364 113481 | 362                                     |

### 22m Endura Blade



(T:0.65)

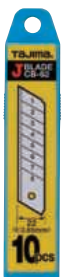
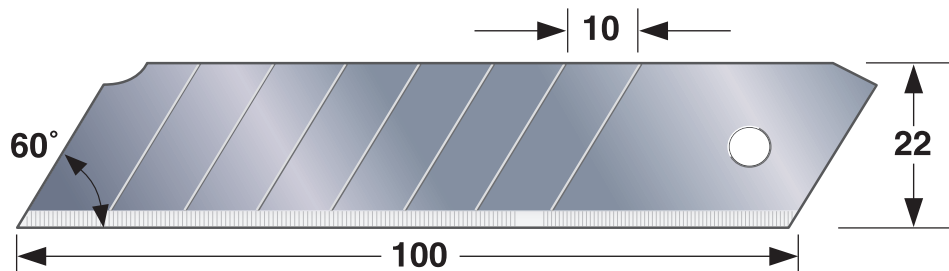

| Art.Nr.  |    | CASE (  ) | MASTER CARTON (  ) | EAN            | Weight ( g )<br>( Packaging + Product ) |
|----------|----|-----------|--------------------|----------------|---|
| CB62H/B1 | 10 | 10 (100)  | 100 (1,000)        | 4975364 021557 | 115                                     |

# LAMES DE RECHANGE POUR CUTTERS

## CUTTER KNIFE BLADES

### 25mm Endura Blade



(T:0.7)

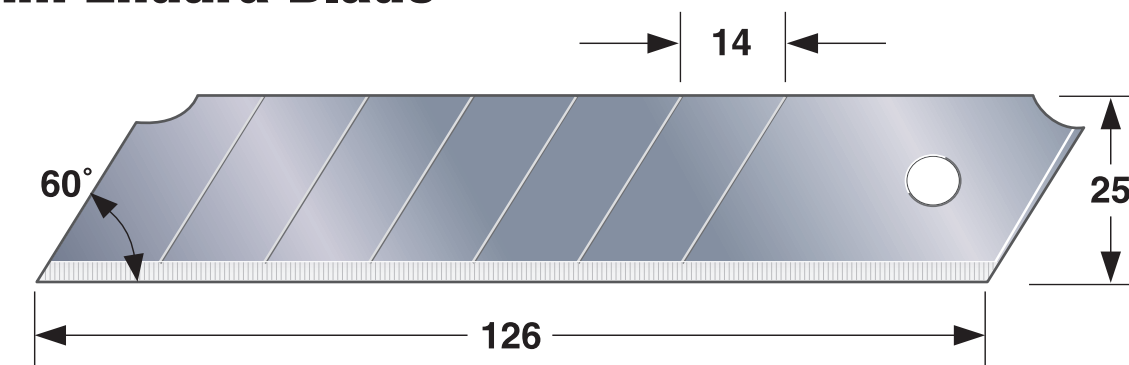

①



②



③



| Art.Nr.     |    | CASE (  ) | MASTER CARTON (  ) | EAN            | Weight ( g )<br>( Packaging + Product ) |
|-------------|----|-----------|--------------------|----------------|---|
| ① LCB65C/Y1 | 10 | 10 (100)  | 60 (600)           | 4975364 020888 | 170                                     |
| ② LCB65N/Y1 | 10 | 10 (100)  | 50 (500)           | 4975364 018861 | 170                                     |
| ③ EH-20HC   | 20 | 10 (200)  | 50 (1,000)         | 4975364 113498 | 366                                     |

### 25mm Solid Endura Blade



(T:0.7)

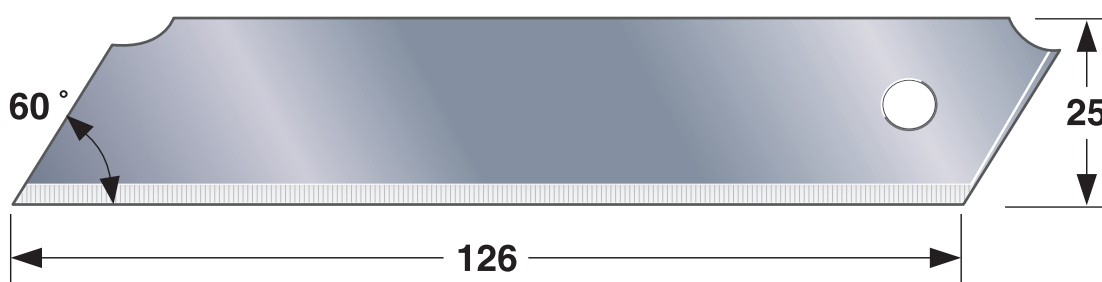

| Art.Nr.       |    | CASE (  ) | MASTER CARTON (  ) | EAN            | Weight ( g )<br>( Packaging + Product ) |
|---------------|----|-----------|--------------------|----------------|---|
| LCB65S-10H/Y1 | 10 | 10 (100)  | 50 (500)           | 4975364 019950 | 204                                     |

# LAMES DE RECHANGE POUR CUTTERS



## CUTTER KNIFE BLADES

### 25mm Razar Black Blade

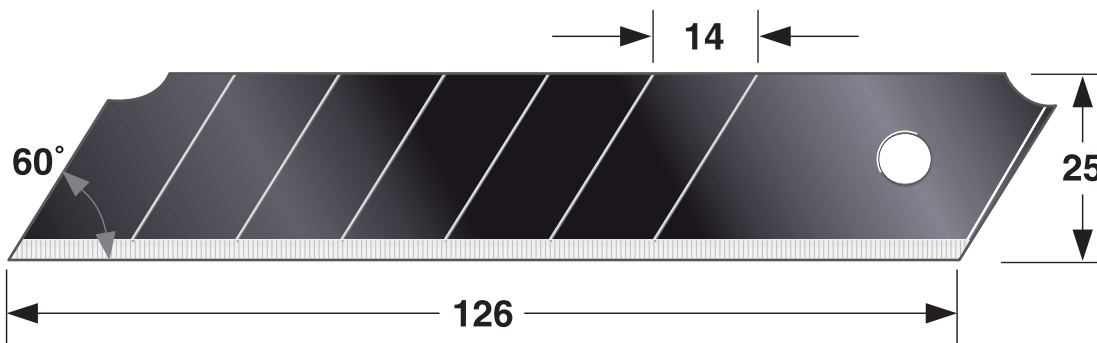

(T:0.7)



| Art.Nr.       |  | CASE (  ) | MASTER CARTON (  ) | EAN            | Weight ( g )<br>( Packaging + Product ) |
|---------------|---|--|--|----------------|---|
| ① LCB65RBC/K1 | 10  | 10 (100)   | 60 (600)   | 4975364 111548 | 170                                     |
| ② CB65RBC/K1  | 10  | 10 (100)   | 60 (600)   | 4975364 111982 | 203                                     |
| ③ RBH-20HC    | 20  | 10 (200)   | 50 (1,000)   | 4975364 113504 | 365                                     |

### Safe Snap



Pour briser proprement les segments des lames de cutter de 9 mm à 25 mm. Le verrouillage de la boîte empêche l'ouverture accidentelle et permet de stocker les segments en toute sécurité.

Cleanly snaps-off blade segments, for all 9 mm - 25 mm cutter blades. Case lock prevents accidental opening, holds segments for safe disposal.

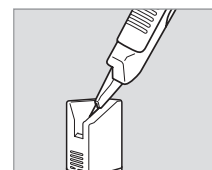

| Art.Nr.  | Detail                        | CASE | MASTER CARTON | EAN            | Weight ( g )<br>( Packaging + Product ) |
|----------|-------------------------------|------|---------------|----------------|---|
| SS001/Y1 | BLADE SEGMENT DISPOSAL SYSTEM | 24   | 120           | 4975364 110732 | 39                                      |

# LAMES DE RECHANGE POUR CUTTERS

## CUTTER KNIFE BLADES

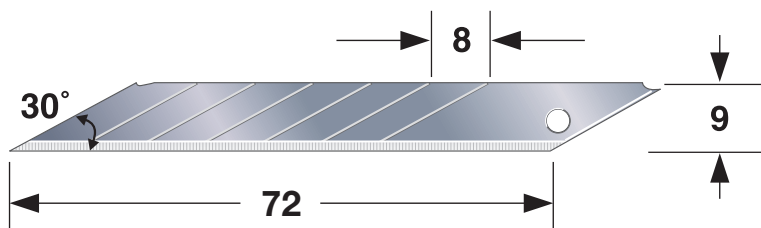

### E3 Endura Blade

weight:2g  
(T:0.38)



Applicable Models



| Art.Nr.  |  | CASE (  ) | MASTER CARTON (  ) | EAN            | Weight ( g )<br>( Packaging + Product ) |
|----------|---|--|--|----------------|---|
| EE3-10HC | 10  | 10 (100)   | 240 (2,400)  | 4975364 113511 | 28                                      |

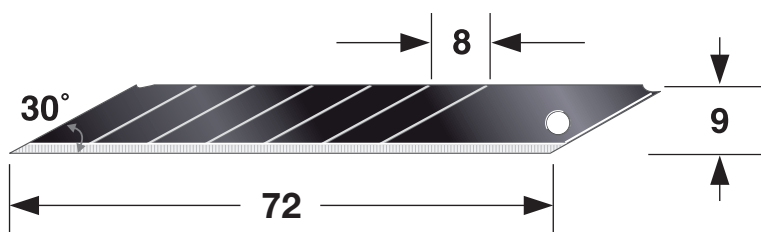

### E3 Razar Black Blade

weight:2g  
(T:0.38)



Applicable Models



| Art.Nr.   |  | CASE (  ) | MASTER CARTON (  ) | EAN            | Weight ( g )<br>( Packaging + Product ) |
|-----------|---|--|--|----------------|---|
| RBE3-10HC | 10  | 10 (100)   | 240 (2,400)  | 4975364 113535 | 28                                      |

# CUTTERS

## CUTTER KNIVES

# DORAFIN



**Cutter tout usage**

A cutter and an all-purpose tool.



**Pour visser les vis à tête fendue**

Driving standard-head screws



**Ouverture de cartons, entaille de cartons épais et forçage de couvercle de boîte.**

Opening cartons, scoring thick cardboard and prying off can lids.



## Dorafin



DFC560W-EUR

[More info](#)



DFC561W-EUR

[More info](#)



| Art.Nr.     |       |   | BLADE LOCK | CASE | MASTER CARTON | EAN            | Weight ( g )<br>( Packaging + Product ) |
|-------------|-------|---|------------|------|---------------|----------------|---|
| DFC560W-EUR | 18 mm | 1 | Auto       | 10   | 120           | 4975364 111890 | 129                                     |
| DFC561W-EUR |       |   | Dial       |      |               | 4975364 111906 | 132                                     |

# CUTTERS

## CUTTER KNIVES

### Dorafin Quick Back



#### CONVEX-SET1

- G3-Lock 27mm 5 m
- Dorafin Quick Back
- Razar Black Blade

More info





### Quick Back

Le système auto-rétractable Tajima offre confort et performance optimale.

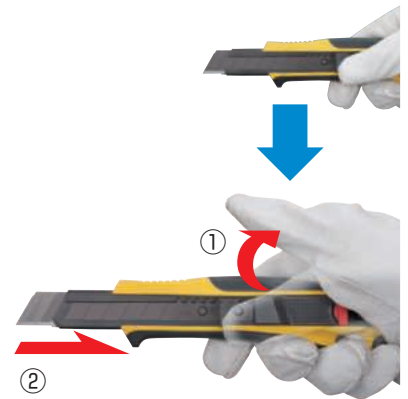
Tajima's self-retracting system is designed to ensure a comfortable grip and optimal performance.



| Art.Nr.       |  |  | BLADE LOCK | CASE | MASTER CARTON | EAN            | Weight ( g )<br>( Packaging + Product ) |
|---------------|---|---|------------|------|---------------|----------------|---|
| DFC579-SY-EUR | 18 mm   | 1   | Quick Back | 10   | 120           | 4975364 113122 | 142                                     |
| CONVEX-SET1   |   | Knife : 1<br>Spare Blade : 10 pcs   |            | 6    | 18            | 4975364 076168 | 4,004 ( 620/pc )                        |

### Safety Holster



#### Applicable Models



DC560Y-EUR



DC561Y-EUR



DFC560W-EUR



DFC561W-EUR



DFC579-SY-EUR



Verrouillage automatique

Positive Lock



Déverrouillage intuitif à une seule main

Intuitive, One-Hand Unlock



Réglable à 45°

Adjustable To 45°

| Art.Nr.    | CASE | MASTER CARTON | EAN            | Weight ( g )<br>( Packaging + Product ) |
|------------|------|---------------|----------------|---|
| DC50SFC/Y1 | 10   | 120           | 4975364 112002 | 132                                     |

# CUTTERS

## CUTTER KNIVES

# Driver Cutter



Série unique de cutters avec guide lame de 1mm extra-dur et extrémité multifonction type "tournevis".

Unique line of knives that feature ultra hard 1 mm thick tempered blade sleeves with multi-function "driver" tips.



**Pour visser les vis à tête fendue**

Driving standard-head screws



**Pour ouvrir les boîtes**

Prying off can lids



**Pour ouvrir les cartons, marquer le carton épais**

Opening cartons, scoring thick cardboard



## Driver Cutter



DC360Y-EUR



DC560RB13D12/Y1



DC561RB13D12/Y1



DC560Y-EUR



DC561Y-EUR



| Art.Nr.         |                |      | BLADE LOCK     | CASE             | MASTER CARTON | EAN            | Weight (g)<br>(Packaging + Product) |
|-----------------|----------------|------|----------------|------------------|---------------|----------------|-------------------------------------|
| DC360Y-EUR      | 9 mm           | 1    | Auto           | 10               | 120           | 4975364 113412 | 48                                  |
| DC560Y-EUR      | 18 mm          | 3    | Auto           | 10               | 120           | 4975364 019929 | 134                                 |
| DC561Y-EUR      |                |      | Dial           |                  |               | 4975364 019936 | 135                                 |
| DC560RB13D12/Y1 |                |      | Knife:3        | Auto             | 12            | 48             | 4975364 110107                      |
| DC561RB13D12/Y1 | Spare blade:10 | Dial | 4975364 110114 | 2,464 ( 182/pc ) |               |                |                                     |

### Safety Holster



#### Modèles compatibles Applicable Models



Verrouillage automatique  
Positive Lock



Déverrouillage intuitif à  
une seule main  
Intuitive, One-Hand Unlock



Réglable à 45°  
Adjustable To 45 °

05

| Art.Nr.    | CASE | MASTER CARTON | EAN            | Weight ( g )<br>( Packaging + Product ) |
|------------|------|---------------|----------------|---|
| DC50SFC/Y1 | 10   | 120           | 4975364 112002 | 132                                     |

# CUTTERS

## CUTTER KNIVES

# ALUMINIST®



**LA FORCE DE COUPE,**  
qui est dirigée vers le centre de la lame, fournit une excellente précision.



**CENTER-BALANCED CUTTING FORCE**  
Cutting force balanced on the center of the blade provides superior cutting precision.

**LE MANCHE ERGONOMIQUE EN ALUMINIUM,**  
avec son système de guidage de lame en acier inox "Heavy-gauge", permet un travail professionnel en toute sécurité.

**DIE-CAST ALUMINUM HANDLE**  
Ergonomically-designed die-cast aluminum handle with a heavy-gauge stainless steel blade guide provides safe and dependable performance.

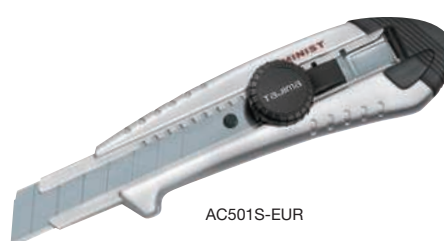
## ALUMINIST®



| Art.Nr.    |  |  | BLADE LOCK | CASE | MASTER CARTON | EAN            | Weight (g)<br>(Packaging + Product) |
|------------|---|---|------------|------|---------------|----------------|-------------------------------------|
| AC500S-EUR | 18 mm   | 3   | Auto       | 10   | 60            | 4975364 017345 | 178                                 |
| AC501S-EUR |   |   | Dial       |      |               | 4975364 017383 | 181                                 |
| AC700S-EUR | 25 mm   |   | Auto       |      |               | 4975364 017352 | 276                                 |
| AC701S-EUR |   |   | Dial       |      |               | 4975364 017390 | 277                                 |

# Rock Hard Fin

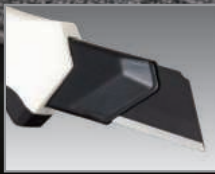

**Le guide lame allongé maintient mieux la lame et réduit les risques de casse.**

Extended blade sleeve supports the edge of blade and it prevents blade breakage.



**Guide lame trempé épaisseur 1,0 mm avec aileron**

1.0 mm thick tempered blade sleeve with fin end

## Rock Hard Fin



DFC670-SW-EUR



[More info](#)



DFC671-SW-EUR

[More info](#)



| Art.Nr.       |  |  | BLADE LOCK | CASE | MASTER CARTON | EAN            | Weight ( g )<br>( Packaging + Product ) |
|---------------|---|---|------------|------|---------------|----------------|---|
| DFC670-SW-EUR | 25 mm   | 2   | Auto       | 6    | 60            | 4975364 112514 | 220                                     |
| DFC671-SW-EUR |   |   | Dial       |      |               | 4975364 112521 | 219                                     |

# CUTTERS

## CUTTER KNIVES

# Top Slider



05



Poignée large pour un dénudage de câble sûr et efficace.



Extended grip ensures safe and efficient cable stripping.



Bouton-poussoir sur le dessus  
Top-slider design

## Top Slider



| Art.Nr.       |  |  | BLADE LOCK | CASE | MASTER CARTON | EAN            | Weight ( g )<br>( Packaging + Product ) |
|---------------|---|---|------------|------|---------------|----------------|---|
| DKC-L590W-EUR | 18 mm   | 1   | Auto       | 10   | 60            | 4975364 111913 | 147                                     |

# Magazine



### GRIP ANTIDERAPANT

Manche revêtu en caoutchouc antidérapant. Antichoc, procurant un confort.

### LIGHTWEIGHT DESIGN



Automatic blade feed, removable magazine and non-slip elastomer grips in a lighter handle design.

# Magazine



Cutter 18 mm gainé élastomère. Le chargeur peut contenir 6 lames. Changement rapide de lame.

Non-slip elastomer grip 18 mm / 3/4 inch cutter holds 6 blades, one blade in the sleeve and 5 blades in the quick-reload magazine.

| Art.Nr.      |  |  | BLADE LOCK | CASE | MASTER CARTON | EAN            | Weight ( g )<br>( Packaging + Product ) |
|--------------|---|---|------------|------|---------------|----------------|---|
| LCM500BK-EUR | 18 mm   | 3   | Auto       | 10   | 60            | 4975364 018441 | 162                                     |

# CUTTERS

## CUTTER KNIVES

# GRI®



**Guide solide de la lame**  
Strong blade sleeve

**GAINAGE CONFORTABLE EN ELASTOMERE**  
intègre de la résine tendre et dure.

COMFORT GRIP KNIVES  
Elastomer grip is ribbed for comfort and sure-grip performance.

## Gri®



LC560Y-EUR



LC561Y-EUR





LC660Y-EUR



LC661Y-EUR



| Art.Nr.    |  |  | BLADE LOCK | CASE | MASTER CARTON | EAN            | Weight (g)<br>(Packaging + Product) |
|------------|---|---|------------|------|---------------|----------------|-------------------------------------|
| LC560Y-EUR | 18 mm   | 1   | Auto       | 10   | 120           | 4975364 113191 | 116                                 |
| LC561Y-EUR |   |   | Dial       |      |               | 4975364 113214 | 117                                 |
| LC660Y-EUR | 25 mm   |   | Auto       | 10   | 60            | 4975364 113139 | 187                                 |
| LC661Y-EUR |   |   | Dial       |      |               | 4975364 113153 | 188                                 |

# DURA



**Cutter gainé élastomère de 25 mm avec un guide lame trempé ultra-dur.**

Elastomer-grip 25 mm/1 inch knife with an ultra-hard tempered blade sleeve.



**Attache pour corde.**  
Tether to a lanyard.

05

## Dura



DC660W-EUR



[More info](#)



DC661W-EUR

[More info](#)



| Art.Nr.    |  |  | BLADE LOCK | CASE | MASTER CARTON | EAN            | Weight ( g )<br>( Packaging + Product ) |
|------------|---|---|------------|------|---------------|----------------|---|
| DC660W-EUR | 25 mm   | 1   | Auto       | 10   | 60            | 4975364 111920 | 180                                     |
| DC661W-EUR |   |   | Dial       |      |               | 4975364 111937 | 181                                     |

# CUTTERS

## CUTTER KNIVES

# Strong-J



22 mm

Les 2 mains peuvent être utilisées pour une force de coupe maximale

Use 2 hands to operate while putting all of your strength into cutting process.



Strong-J Grip/Strong-J Long

Guide lame trempé 3,5 fois plus résistant que les modèles standards.

Hardened holder, 3.5 times stronger (in-house comparison)

## Strong-J Grip



22 mm

Convient pour un usage ambidextre.

Convenient size to use with both hands and to fit tool pouch.



More info



| Art.Nr.     |  |  | BLADE LOCK | CASE | MASTER CARTON | EAN            | Weight ( g )<br>( Packaging + Product ) |
|-------------|---|---|------------|------|---------------|----------------|---|
| DC690-Y1-10 | 22 mm   | 10  | Auto       | 6    | 24            | 4975364 112507 | 2,934 ( 449/pc )                        |

# CUTTERS

## CUTTER KNIVES

### Strong-J Long



Prise en main sur une grande longueur 180 mm pour une meilleure rapidité et force de coupe.

Long grip of about 180 mm for enhanced cutting speed and power.

05

| Art.Nr.     |  |  | BLADE LOCK | CASE | MASTER CARTON | EAN            | Weight (g)<br>(Packaging + Product) |
|-------------|---|---|------------|------|---------------|----------------|-------------------------------------|
| DC680-Y1-10 | 22 mm   | 10  | Auto       | 6    | 24            | 4975364 112736 | 1,900 (267/pc)                      |

### Strong-J Standard



Série unique de cutters avec guide lame de 1mm extra-dur et extrémité multifonction type "tournevis".

Hardened hook convenient to cut, poke and pry



Guide lame renforcé en acier inox d'une épaisseur de 1 mm permettant d'appliquer une force maximum. Nouvelle ergonomie qui transmet plus de force sur la lame.

Palm fit grip that fits with your hand

| Art.Nr.     |  |  | BLADE LOCK | CASE | MASTER CARTON | EAN            | Weight (g)<br>(Packaging + Product) |
|-------------|---|---|------------|------|---------------|----------------|-------------------------------------|
| DC610-Y1-10 | 22 mm   | 10  | Auto       | 6    | 24            | 4975364 112729 | 1,720 (233/pc)                      |

# CUTTERS

## CUTTER KNIVES

# Standard Cutter



05



## LC CLASSIC



LC303Y-EUR





LC303B-EUR



Cutter compact 9 mm avec 2 lames dans le magasin. Blocage par bouton-poussoir. Agrafe-stylo, casse-lame.

Slim handle 9 mm Slide Blade Lock knife with in-handle blade storage and 3 Endura blades.

| Art.Nr.    |  |  | BLADE LOCK | CASE | MASTER CARTON | EAN            | Weight ( g )<br>( Packaging + Product ) |
|------------|---|---|------------|------|---------------|----------------|---|
| LC303Y-EUR | 9 mm  | 3   | Auto       | 10   | 120           | 4975364 113306 | 43                                      |
| LC303B-EUR |   |   |            |      |               | 4975364 113313 |   |

# CUTTERS

## CUTTER KNIVES

### LC Classic



LC500Y-EUR





500C40/A1



LC501Y-EUR



501A40/A1

| Art.Nr.    |  |  | BLADE LOCK | CASE | MASTER CARTON  | EAN            | Weight ( g )<br>( Packaging + Product ) |
|------------|---|---|------------|------|----------------|----------------|---|
| LC500Y-EUR | 18 mm   | 3   | Auto       | 10   | 120            | 4975364 112972 | 102                                     |
| LC500B-EUR |   |   |            | 10   | 120            | 4975364 112989 | 102                                     |
| 500C40/A1  |   |   |            | 40   | 120 ( 3 SETS ) | 4975364 021380 | 3,420 ( 79/pc )                         |
| LC501Y-EUR |   |   | Dial       | 10   | 120            | 4975364 113016 | 105                                     |
| LC501B-EUR |   |   |            | 10   | 120            | 4975364 113009 | 105                                     |
| 501A40/A1  |   |   |            | 40   | 120 ( 3 SETS ) | 4975364 021465 | 3,500 ( 81/pc )                         |

### LC Classic

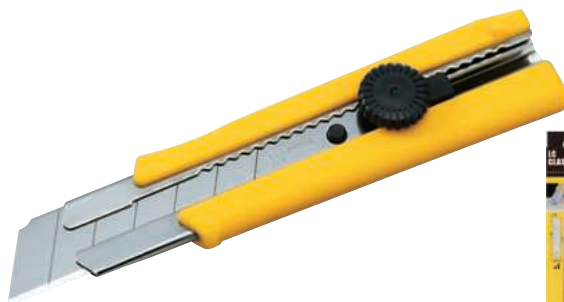

Cutter 25 mm renforcé , extra résistant , gainé élastomère et guide-lame en acier inox plus épais pour un usage intensif dans des conditions les plus contraignantes.

Extra heavy duty 25 mm Dial Blade Lock knife with a thick elastomer grip.

| Art.Nr.    |  |  | BLADE LOCK | CASE | MASTER CARTON | EAN            | Weight ( g )<br>( Packaging + Product ) |
|------------|---|---|------------|------|---------------|----------------|---|
| LC650Y-EUR | 25 mm   | 1   | Dial       | 10   | 120           | 4975364 113054 | 150                                     |

# CUTTERS

## CUTTER KNIVES

### LC Classic PRO



LC520Y-EUR



520H40/A1



LC521Y-EUR





521H40/A1TAG



LC620Y-EUR



| Art.Nr.      |  |  | BLADE LOCK | CASE | MASTER CARTON | EAN            | Weight (g)<br>(Packaging + Product) |
|--------------|---|---|------------|------|---------------|----------------|-------------------------------------|
| LC520Y-EUR   | 18 mm   | 3   | Auto       | 10   | 120           | 4975364 113030 | 105                                 |
| 520H40/A1    |   |   |            | 40   | 120 (3 SETS)  | 4975364 019080 | 3,560 (83/pc)                       |
| LC521Y-EUR   |   |   | Dial       | 10   | 120           | 4975364 113047 | 110                                 |
| 521H40/A1TAG |   |   |            | 40   | 120 (3 SETS)  | 4975364 019097 | 3,720 (87/pc)                       |
| LC620Y-EUR   | 22mm  |   | Auto       | 10   | 120           | 4975364 112019 | 130                                 |

# CUTTERS

## CUTTER KNIVES

### Precision Craft Basic





Cutter multi-usages 9 mm. Blocage par bouton-poussoir.

Multi-purpose 9 mm Slide Blade Lock knives equipped with Endura blades, in a 3-color 60 pc. displayer.



305D60/A1

| Art.Nr.   |  |  | BLADE LOCK | CASE | MASTER CARTON  | EAN            | Weight ( g )<br>( Packaging + Product ) |
|-----------|---|---|------------|------|----------------|----------------|---|
| 305D60/A1 | 9 mm  | 1   | Auto       | 60   | 240 ( 4 SETS ) | 4975364 021212 | 900 ( 11/pc )                           |

### LCM CLASSIC



Pointe effilée pour atteindre les espaces étroits.

Sleek and lightweight stainless steel 9 mm Slide Blade Lock knife with 3 Endura blades.



| Art.Nr.   |  |  | BLADE LOCK | CASE | MASTER CARTON | EAN            | Weight ( g )<br>( Packaging + Product ) |
|-----------|---|---|------------|------|---------------|----------------|---|
| LC301-EUR | 9 mm  | 3   | Auto       | 10   | 120           | 4975364 113276 | 37                                      |

# CUTTERS

## CUTTER KNIVES

# Extra Specialty Cutter Knives

05



## E3 DORA

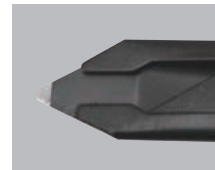

Lame en acier trempé avec pointe multifonction "micro-driver".

Tempered blade sleeve with a multifunction "micro-driver" tip.



More info



| Art.Nr.     |  |  | BLADE LOCK | CASE | MASTER CARTON | EAN            | Weight ( g )<br>( Packaging + Product ) |
|-------------|---|---|------------|------|---------------|----------------|---|
| DC395BK-EUR | 9 mm  | 1   | Auto       | 10   | 120           | 4975364 113429 | 39                                      |

# CUTTERS

## CUTTER KNIVES

### E3

Pointe effilée pour atteindre les espaces étroits.

For cutting and scoring in tight spaces.



05

| Art.Nr.   |  |  | BLADE LOCK | CASE | MASTER CARTON | EAN            | Weight ( g )<br>( Packaging + Product ) |
|-----------|---|---|------------|------|---------------|----------------|---|
| LC390-EUR | 9 mm  | 3   | Auto       | 10   | 120           | 4975364 113405 | 37                                      |

# LAMES DE COUTEAUX UTILITAIRES

## UTILITY KNIFE BLADES

### V-Rex

Lame tranchante comme un rasoir avec un angle de coupe particulièrement aigu.

A razor-sharp acute angle blade



06

### V-Rex II



Lames en acier trempé supérieure avec un tranchant lame de rasoir, optimisées pour les cloisons sèches et autres travaux de coupe et de grattage.

Premium tempered steel blades with razor-sharp cutting edges, optimized for drywall and other heavy-duty cutting and scoring tasks.

| Art.Nr.0     |     | BLADE TYPE | Corresponding Knives                      | CASE     | MASTER CARTON | EAN            | Weight (g)<br>(Packaging + Product) |
|--------------|-----|------------|---|----------|---------------|----------------|-------------------------------------|
| VRB2-10B/Y1  | 10  | V-REX II   | VR101D / R1<br>VR102D / B1<br>VR103D / S1 | 10  100  | 120  1200     | 4975364 019578 | 56                                  |
| VRB2-50B/Y1  | 50  |            |   | 10  500  | 40  2000      | 4975364 019530 | 258                                 |
| VRB2-100B/Y1 | 100 |            |   | 10  1000 | 40  4000      | 4975364 019547 | 448                                 |

### Deep Hook



Lames à crochet échancré de haute qualité, antiglisse, conçues pour la coupe de matériaux de couverture ou de revêtement de sol.



Premium-grade deep hook blades designed to prevent slip-off when cutting rigid roofing or flooring material.

| Art.Nr.           |    | BLADE TYPE | Corresponding Knives                      | CASE    | MASTER CARTON | EAN                   | Weight (g)<br>(Packaging + Product) |
|-------------------|----|------------|---|---------|---------------|-----------------------|-------------------------------------|
| HKB-10B/Y1        | 10 | DEEP HOOK  | VR101D / R1<br>VR102D / B1<br>VR103D / S1 | 10  100 | 120  1200     | 4975364 019585        | 49                                  |
| HKB-50B/<br>Y1USA | 50 |            |   | 10  500 | 40  2000      | 049296019556<br>(UPC) | 227                                 |

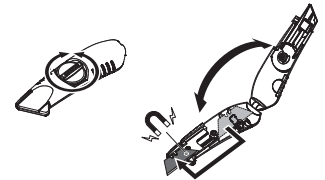
## V-Rex FIXED TYPE





- Couteau robuste à lame rétractable
- Ouverture facilitée par une large vis à ailette
- Rugged one-piece fixed blade utility knife
- Open easily with a large thumb-screw

| Art.Nr.    |  |  | BLADE LOCK | CASE | MASTER CARTON | EAN            | Weight ( g )<br>( Packaging + Product ) |
|------------|---|---|------------|------|---------------|----------------|---|
| VR101R-EUR | 19 mm   | 3   | FIXED TYPE | 10   | 60            | 4975364 113238 | 178                                     |

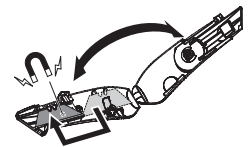
## V-Rex RETRACTABLE TYPE



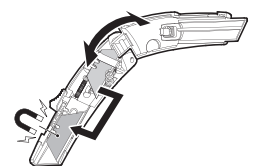

| Art.Nr.    |  |  | BLADE LOCK       | CASE | MASTER CARTON | EAN            | Weight ( g )<br>( Packaging + Product ) |
|------------|---|---|------------------|------|---------------|----------------|---|
| VR102B-EUR | 19 mm   | 3   | RETRACTABLE TYPE | 10   | 60            | 4975364 113368 | 236                                     |

## V-Rex Safety Knife



- Lame auto rétractable
- Mécanisme de blocage bien positionné
- Self-retracting utility knife
- Conveniently located slide lock mechanism

| Art.Nr.    |  |  | BLADE LOCK | CASE | MASTER CARTON | EAN            | Weight ( g )<br>( Packaging + Product ) |
|------------|---|---|------------|------|---------------|----------------|---|
| VR103S-EUR | 19 mm   | 3   | Quick Back | 10   | 60            | 4975364 113375 | 197                                     |

# COUTEAU DE SECURITE

## SAFETY KNIFE

# Safety Knife

La lame se rétracte automatiquement dès qu'elle n'est plus en contact avec la matière à couper.

Auto-retract blade when it leaves the cutting material.

### Utilisation simple 3 Stufen

The simple usage 3 steps



① Sortir la lame et commencer à couper.

① Slide out the blade and start cutting.



② Ne pas mettre le pouce sur le coulisseau en coupant.

② While cutting, do not hold thumb on slider.



③ La lame se rétracte automatiquement dès qu'elle n'est plus en contact avec la matière à couper.

③ Knife automatically retracts the blade as soon as the blade is released from your cutting material.

## Safety Knife



Design sécurité avec lame auto-rétractable. Bouton de verrouillage pour éviter la sortie involontaire de la lame.

Safety design with auto blade retraction. Slider lock prevents blade from sticking out unexpectedly.

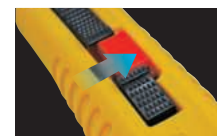

| Art.Nr.   |  | BLADE LOCK | CASE | MASTER CARTON | EAN            | Weight ( g )<br>( Packaging + Product ) |
|-----------|---|------------|------|---------------|----------------|---|
| LC959X/Y1 | 1   | Quick Back | 10   | 120           | 4975364 112064 | 110                                     |

## Safety Knife Blade

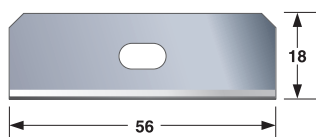

Le tranchant de la lame peut être utilisé sur toute sa longueur. Lame sans cran pour un usage plus sûr.

Both sides of the blade can be used. Blade without notch for safer use.

| Art.Nr.  |  | CASE | MASTER CARTON | EAN            | Weight ( g )<br>( Packaging + Product ) |
|----------|---|------|---------------|----------------|---|
| CB93H/Y1 | 10  | 20   | 240           | 4975364 112071 | 50                                      |

# Cutter Guide

Règle guide-cutter professionnelle avec graduation métrique. Corps en aluminium profilée pour les doigts et guide lames en acier inoxydable.

Professional grade cutter guide with a precise metric scale. Hollow-core aluminum design with ribbed finger hold and stainless steel guide.

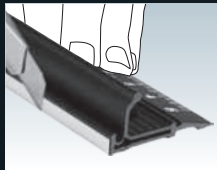

**Guides en acier inoxydable**  
Stainless steel guides



**Base antidérapante**  
Non-slip base



09

## Cutter Guide Slim

### 300 / 600 / 1000

Protection doigts hauteur 18,5 mm pour plus de sécurité et contrôle positif. Le guide lames en acier inoxydable ne peut pas être endommagé au contact de la lame.

18.5 mm raised finger guard for safety and positive control. Stainless steel guides won't nick or scratch from cutter blades.



CTGSL300/K1



CTGSL600/K1



CTGSL1000/K1

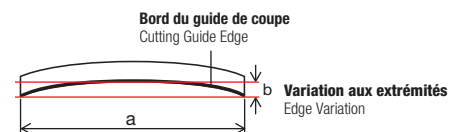

| Art.Nr.      |         |                           | b              |          | CASE | MASTER CARTON | EAN            | Weight (g)<br>(Packaging + Product) |
|--------------|---------|---------------------------|----------------|----------|------|---------------|----------------|-------------------------------------|
| CTGSL300/K1  | 300 mm  | 310 mm (±0.2 mm) × 40 mm  | Edge Variation | 0-0.3 mm | 10   | 80            | 4975364 163974 | 100                                 |
| CTGSL600/K1  | 600 mm  | 610 mm (±0.28 mm) × 40 mm |                | 0-0.6 mm |      | 40            | 4975364 163981 | 220                                 |
| CTGSL1000/K1 | 1000 mm | 1010 mm (±0.4 mm) × 40 mm |                | 0-1.0 mm |      | 20            | 4975364 165008 | 320                                 |

# PRODUITS SPÉCIAUX

## SPECIALTY TOOLS

# Clipper

**Revêtement fluorine des lames**

Premium Fluoro-coat Blade



**Anti-adhésif**  
Non stick



**Tranchant cranté pour**  
Serrated blade edges  
( CPG175B/Y1 )



09

## Clipper 160 / 210

Ciseaux de haute précision.  
Revêtement Fluoro anti-adhésif.  
Prise en main agréable.

Precision scissors for precise cuts.  
Premium Fluoro-Coat Blade Coating prevents sticking to  
material your cutting.  
Nice cutting action, feels great in the hand.



CLP160B/Y1



CLP210B/Y1



More info

| Art.Nr.    |  | FEATURES                  | CASE | MASTER CARTON | EAN            | Weight ( g )<br>( Packaging + Product ) |
|------------|---|---------------------------|------|---------------|----------------|---|
| CLP160B/Y1 | 160 mm  | Premium Fluoro-Coat Blade | 10   | 100           | 4675364 112033 | 55                                      |
| CLP210B/Y1 | 210 mm  |                           |      |               | 4975364 112040 | 120                                     |

### Clipper 175 Garden Scissors

Tranchant cranté pour une meilleure taille.  
Revêtement Fluoro anti-adhésif.

Enhance control when pruning.  
Premium Fluoro-Coat Blade Coating prevents sticking to material your cutting.



09

| Art.Nr.    |  | FEATURES                  | CASE | MASTER CARTON | EAN            | Weight ( g )<br>( Packaging + Product ) |
|------------|---|---------------------------|------|---------------|----------------|---|
| CPG175B/Y1 | 175 mm  | Premium Fluoro-Coat Blade | 10   | 100           | 4975364 112057 | 80                                      |

# PRODUITS SPÉCIAUX

## SPECIALTY TOOLS

# For electrical and utility work

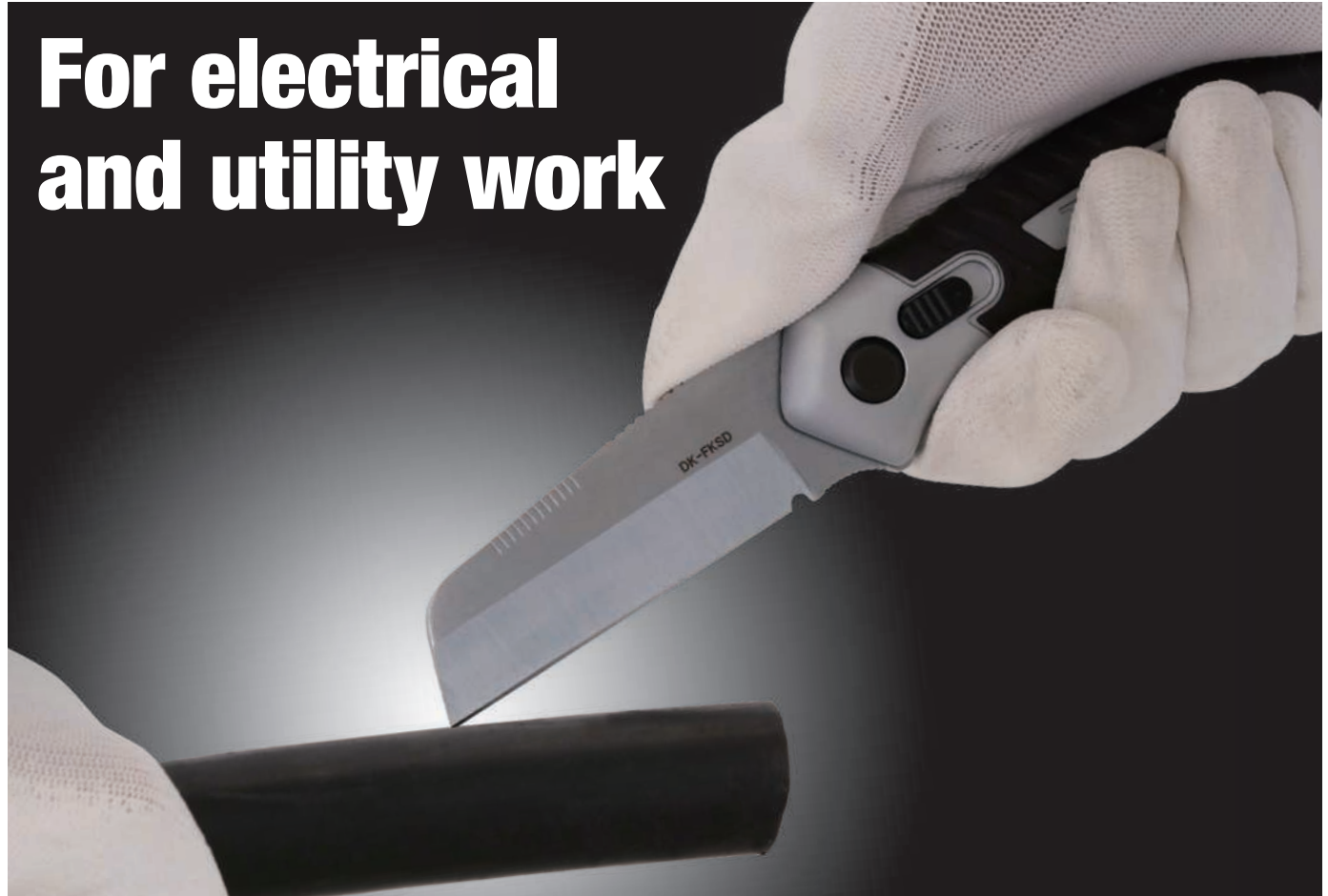

09

## Foldable Blade Multi-purpose Knife

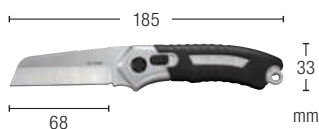

- Bien en main , utilisation facile , portable
- Blocage de sécurité qui maintient la lame rétractée
- Compact size — easy to use, portable
- Safety lock ensures blade stays retracted



Mécanisme de blocage par bouton coulissant de sécurité

Slide safety lock mechanism  
Ensures blade stays retracted, or does not close while in use



Oeillet de maintien ( dia. 5,2 mm )

Ring sleeve( small )Holding eye ( ø5.2 mm )  
Insert up to 4 cords easily  
(Also accommodates safety rope)

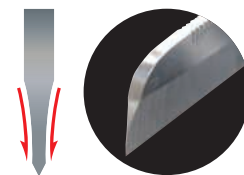

Lame en forme évidée  
Hollow-shaped blade

| Art.Nr.     | CASE | MASTER CARTON | EAN            | Weight ( g )<br>( Packaging + Product ) |
|-------------|------|---------------|----------------|---|
| DK-FKSD-EUR | 6    | 36            | 4975364 267894 | 145                                     |

# PRODUITS SPÉCIAUX

## SPECIALTY TOOLS

### Mini Knife for Cables



Blade protector

- Se tient bien en pleine main
- Une mini lame de 43 mm pour dénuder les câbles
- Polissage fin en surface
- Gainage en élastomère anti dérapant

- Just fit to a hand & Compact Body Size
- "43mm" Mini-Blade, Best for stripping off cable coating
- Fine Finish Surface
- Non-slip Elastomer Grip with Globe wearing



Tête de frappe

Striking End-grip blade



Nouvelle forme originale de lame

The original new shape of Top-blade

| Art.Nr.     | CASE | MASTER CARTON | EAN            | Weight ( g ) ( Packaging + Product ) |
|-------------|------|---------------|----------------|--------------------------------------|
| DK-TNMN-EUR | 6    | 36            | 4975364 267887 | 105                                  |

### Holster for Mini Knife for Cables



**Wearable Adjustable Belt Sizes**  
Up to 53 mm wide  
Up to 3.0 mm thick



Avec un étui sécurité de ceinture

Includes Safety Belt Holder — attach while wearing belt

| Art.Nr.      | CASE | MASTER CARTON | EAN            | Weight ( g ) ( Packaging + Product ) |
|--------------|------|---------------|----------------|--------------------------------------|
| DK-MSFHS-EUR | 6    | 36            | 4975364 267900 | 135                                  |

### Cable Mate Knife



Protege lame

Blade protector

Couteau d'électricien multi usages. La lame Solid-Core est formée d'une seule pièce continue en acier inoxydable et peut être utilisée avec un marteau comme un ciseau à frapper.

Multi-purpose electrician's knife. Solid-Core blade is formed from one continuous piece of stainless steel and can be used with a hammer for chisel-like tasks.



Large surface de frappe

Large striking area

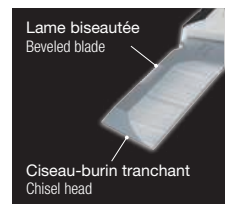

Lame biseautée  
Beveled blade

Ciseau-burin tranchant  
Chisel head

| Art.Nr.    | CASE | MASTER CARTON | EAN            | Weight ( g ) ( Packaging + Product ) |
|------------|------|---------------|----------------|--------------------------------------|
| DKTN80X/W1 | 10   | 80            | 4975364 164018 | 167                                  |

# PRODUITS SPÉCIAUX

## SPECIALTY TOOLS

### Varix Scissors

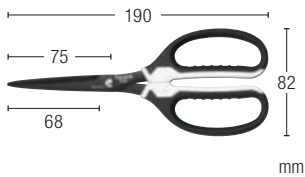

#### Cutting ability

- Tape
- Thin wires
- PP-Band

- Ciseaux d'électriciens ainsi que d'utilité générale
- Longues lames , coupe d'un coup proprement les rubans de 50 mm de large

- Scissors for electrical and utility work • Safety lock ensures blade stays retracted
- Long blades, cut wide tape (50 mm) clean in one snip



Crans à la base pour couper sans glisser les fils fins

Serrations at base cut thin wires without slipping



Lame revêtue de silicone résiste à l'accumulation de colle.

Silicone-coated blade resists glue build-up



Etui de protection des lames quand pas utilisé

Blade case protects blades while stored

| Art.Nr.     | CASE | MASTER CARTON | EAN            | Weight ( g ) ( Packaging + Product ) |
|-------------|------|---------------|----------------|--------------------------------------|
| DK-BT70-EUR | 6    | 36            | 4975364 267917 | 110                                  |

### Varix Tradesman Shears

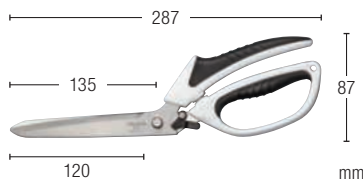

#### Cutting ability

- Glass wool
- Rock wool
- Rubber, sound-insulating sheet
- PP-Band
- Protective panel
- Wire mesh

- Nouveau , facile d'utilisation pour couper les grandes longueurs
- Pour couper les matériaux d'isolation

- New, easy-to-use shape cuts long lengths
- Perfect also for carpenters working with insulation material



Mécanisme à ressort permettant l'utilisation d'une main

Spring mechanism allows use with one hand

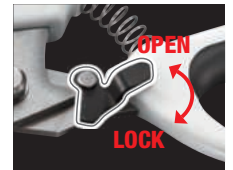

Verrouillage d'une seule touche et déverrouillage facile d'une main

One-touch lock



Etui de protection des lames quand pas utilisé

Blade case protects blades while stored

| Art.Nr.      | CASE | MASTER CARTON | EAN            | Weight ( g ) ( Packaging + Product ) |
|--------------|------|---------------|----------------|--------------------------------------|
| DK-BD120-EUR | 4    | 24            | 4975364 267924 | 385                                  |

# PRODUITS SPÉCIAUX

## SPECIALTY TOOLS

### Top slider



Poignée étendue pour un dénudage de câble sûr et efficace.

Extended grip ensures safe and efficient cable stripping.



Bouton-poussoir sur le dessus

Top-slider design



| Art.Nr.       |  |  | BLADE LOCK | CASE | MASTER CARTON | EAN            | Weight ( g )<br>( Packaging + Product ) |
|---------------|---|---|------------|------|---------------|----------------|---|
| DKC-L590W-EUR | 18 mm   | 1   | Auto       | 10   | 60            | 4975364 111913 | 147                                     |

### Multi-purpose Cable Cutter



Ciseaux multi-usages. Lame traitée plaquée chrome pour couper câbles et plaques de métal doux. Crans au dos de la lame pour ébavurer.

Multi-purpose scissors. Hard Chrome Plated Blade cuts cables and sheet metals. Grooves on back of the blade help deburring.

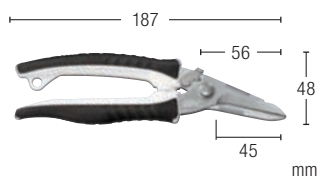
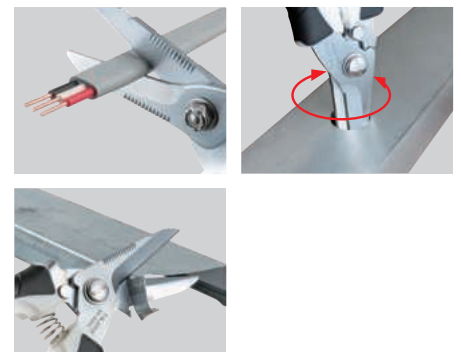

| Art.Nr.    | CASE | MASTER CARTON | EAN            | Weight ( g )<br>( Packaging + Product ) |
|------------|------|---------------|----------------|---|
| DKBB50B/W1 | 6    | 36            | 4975364 162045 | 167                                     |

# GRATTOIRS SCRAPERS

## Scrape-Rite® P

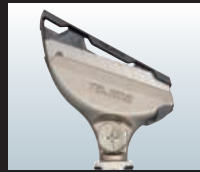

### Gaine sécurité de protection de la lame.

Protective blade cover for your safety.



### Utilisation possible des 2 côtés de la tête.

It can be used identically even when the head is turned over.



### Poignée ergonomique.

Ergonomic grip for smooth handling.

### Changement de lame

Blade Replacement



### Aucun outil nécessaire. Utiliser un tournevis uniquement pour resserrer.

No tools needed. Use a screwdriver only if it needs to be tightened.



### Presse lame monté sur ressort pour éviter son glissement pendant le changement. Les 2 côtés de la lame peuvent être utilisés.

Spring-loaded blade clamp to prevent the blade from sliding off when replacing blades. Both cutting edge and blunt side of the blade can be used.

**Lames recommandées / Applicable blade**  
LCB-50, LCB-50RBC, LCB-50DC, LCB-50SN, CB-62

10

## Scrape-Rite® P Flat Head



La tête plate à angle droit avec la poignée permet un accès à ras de la surface. Utilisation possible des 2 côtés de la tête.

The flat head which is vertical to the handle works best for evening out surfaces.

It can be used identically even when the head is turned over.



More info



| Art.Nr.     |        |       |   | BLADE        | CASE | MASTER CARTON | EAN            | Weight ( g )<br>( Packaging + Product ) |
|-------------|--------|-------|---|--------------|------|---------------|----------------|---|
| PSCL300F/W1 | 305 mm | 18 mm | 3 | ENDURA-BLADE | 6    | 24            | 4975364 058034 | 400                                     |

## Scrape-Rite® P Angled Head

La tête inclinée à 20° est très pratique pour enlever le papier peint.

Blocage de la lame pour l'empêcher de glisser. Choisissez la bonne longueur de manche selon l'utilisation.

The 20° angled head against the handle works best for scraping off materials like wallpaper.

Blade stopper prevents the blade from sliding down. Choose a right handle length based on your usage and workflow.





PSCL300A/W1



PSCL500A/W1

More info



| Art.Nr.     |  |  |  | BLADE        | CASE | MASTER CARTON | EAN            | Weight ( g )<br>( Packaging + Product ) |
|-------------|---|---|---|--------------|------|---------------|----------------|---|
| PSCL300A/W1 | 330 mm  | 18 mm   | 3   | ENDURA-BLADE | 6    | 24            | 4975364 058010 | 400                                     |
| PSCL500A/W1 | 520 mm  |   |   |              |      | 12            | 4975364 058027 | 550                                     |

# GRATTOIRS

## SCRAPERS

### Scrape-Rite® P

#### Solid Core Optimal Blade



**La longue lame éloigne les débris de la tête de frappe.**

The longer blade prevents scraped debris from hitting the scraper head.



**La tête plus basse que la poignée évite les débris d'atteindre les mains.**

The head is set at a lower level than the handle when using so it avoids your hands getting hit by debris.



**Poignée ergonomique.**

Ergonomic grip for smooth handling.

10

### Scrape-Rite® P

#### Solid Core Flexible



Les bords arrondis de la lame évitent l'endommagement de ses matériaux.

Round shaped edges of the blade prevent it's material from being damaged.

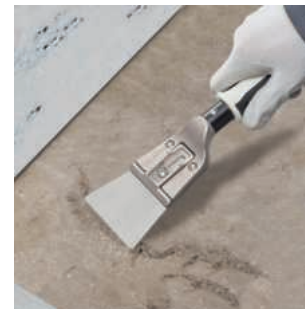



**Lame flexible.**  
Selon l'usage, la flexibilité de la lame peut être ajustée.

Flexible Blade  
Based on your usage, please adjust flexure of the blade.

More info



| Art.Nr.      |  |  | CASE | MASTER CARTON | EAN            | Weight ( g )<br>( Packaging + Product ) |
|--------------|---|---|------|---------------|----------------|---|
| PHR250F80/W1 | 280 mm  | 80 mm   | 6    | 24            | 4975364 058065 | 360                                     |

## Scrape-Rite® P Solid Core Hard



PHR250H80/W1

PHR500H80/W1

Lame extra épaisse pour gratter les matières dures.

Extra thick hard blade for scraping off hard materials.

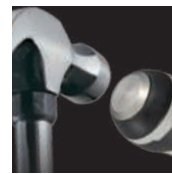



Tête avec large plaque de frappe pour faciliter l'utilisation d'un marteau.

Extra-wide striking head offers a large target area for safer and easier hammering applications.

10



| Art.Nr.      |  |  | CASE | MASTER CARTON | EAN            | Weight (g)<br>(Packaging + Product) |
|--------------|---|---|------|---------------|----------------|-------------------------------------|
| PHR250H80/W1 | 285 mm  | 80 mm   | 6    | 24            | 4975364 058041 | 420                                 |
| PHR500H80/W1 | 565 mm  |   |      | 12            | 4975364 058058 | 610                                 |

## Replacement Blade

PHR250F80/W1  
Replacement blade



PHR- FB80/-1

PHR250H80/W1  
PHR500H80/W1  
Replacement blade



PHR-HB80/-1



| Art.Nr.     |  | CASE | MASTER CARTON | EAN            | Weight (g)<br>(Packaging + Product) |
|-------------|---|------|---------------|----------------|-------------------------------------|
| PHR-FB80/-1 | 80 mm   | 4    | 36            | 4975364 058089 | 50                                  |
| PHR-HB80/-1 |   |      |               | 4975364 058072 | 80                                  |

# GRATTOIRS SCRAPERS

## Scrape-Rite® Solid Core

Le grattoir est formé d'une seule pièce d'acier monobloc inoxydable de haute qualité dont le manche se termine par une large tête de frappe. L'énergie de la frappe du marteau est directement transmise de la tête sur la lame, d'où une performance plus rapide et efficace, et un contrôle exceptionnel de l'outil.

Scrape-Rite Solid Core is formed from one continuous piece of premium stainless steel and capped with a wide striking head.

Hammer impact to the head is conveyed directly to the blade resulting in faster, more efficient performance and exceptional control.



### LAME PLUS ROBUSTE

Les lames ultra-épaisses (1.8mm) en acier inoxydable sont traitées et trempées thermiquement pour garantir plus de solidité et de longévité.

### STRONGER BLADE

Extra-thick 1.8mm stainless steel blades are heat treated and hardened for superior strength and dependable performance.



### UNE MEILLEURE PRISE

Les manches en résine dure résistent aux chocs. Ils sont dessinés de façon ergonomique et antidérapante pour fournir un confort exceptionnel, et un contrôle sûr de l'outil.

### SUPERIOR GRIP

Hardened resin handles are impact-resistant and ergonomically designed to provide exceptional comfort and positive, non-slip control.

### TÊTE EXTRA-LARGE POUR PERMETTRE UNE FRAPPE EFFICACE

Les têtes épaisses en acier inoxydable sont extrêmement résistantes et offrent une cible large pour une utilisation plus facile et en toute sécurité du marteau.

### EXTRA-WIDE STRIKING HEAD

Thick stainless steel striking heads are extremely durable and offer a large target area for safer and easier hammering applications.

## Scrape-Rite® Solid Core



Lame de forme classique destinée aux travaux de grattage courants.

Traditionally flared blades for common scraping tasks.

| Art.Nr.   |  | CASE | MASTER CARTON | EAN            | Weight (g) (Packaging + Product) |
|-----------|---|------|---------------|----------------|----------------------------------|
| SCRC50/Y1 | 50 mm   | 12   | 96            | 4975364 017970 | 180                              |
| SCRC75/Y1 | 75 mm   |      |               | 4975364 017987 | 200                              |

## Scrape-Rite® Solid Core Fishtail Blade



Lame large forme queue de poisson, Pour une utilisation dans les angles et dans les endroits peu accessibles où les autres lames ne passent pas.

Wide fishtail blades for corners and recessed areas that other blades can't reach.



| Art.Nr.   |  | CASE | MASTER CARTON | EAN            | Weight (g) (Packaging + Product) |
|-----------|---|------|---------------|----------------|----------------------------------|
| SCRN95/Y1 | 95 mm   | 12   | 96            | 4975364 018007 | 200                              |

# GRATTOIRS SCRAPERS

## Scrape-Rite® Solid Core Multi-Tool Blade



Lame combinant plusieurs profils et destinée à être utilisée pour de multiples travaux de grattage.  
All-in-one blade designed to handle multiple scraping tasks.

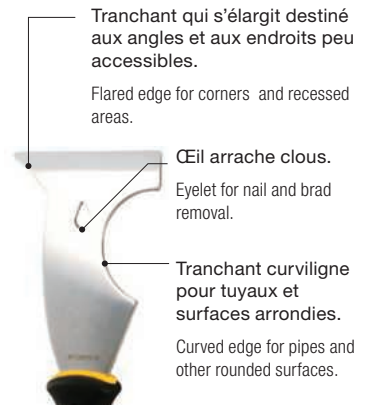

Tranchant qui s'élargit destiné aux angles et aux endroits peu accessibles.  
Flared edge for corners and recessed areas.

Œil arrache clous.  
Eyelet for nail and brad removal.

Tranchant curviligne pour tuyaux et surfaces arrondies.  
Curved edge for pipes and other rounded surfaces.

| Art.Nr.   |  | CASE | MASTER CARTON | EAN            | Weight (g) (Packaging + Product) |
|-----------|---|------|---------------|----------------|----------------------------------|
| SCRM75/Y1 | 75 mm   | 12   | 96            | 4975364 018021 | 180                              |

## Scrape-Rite®

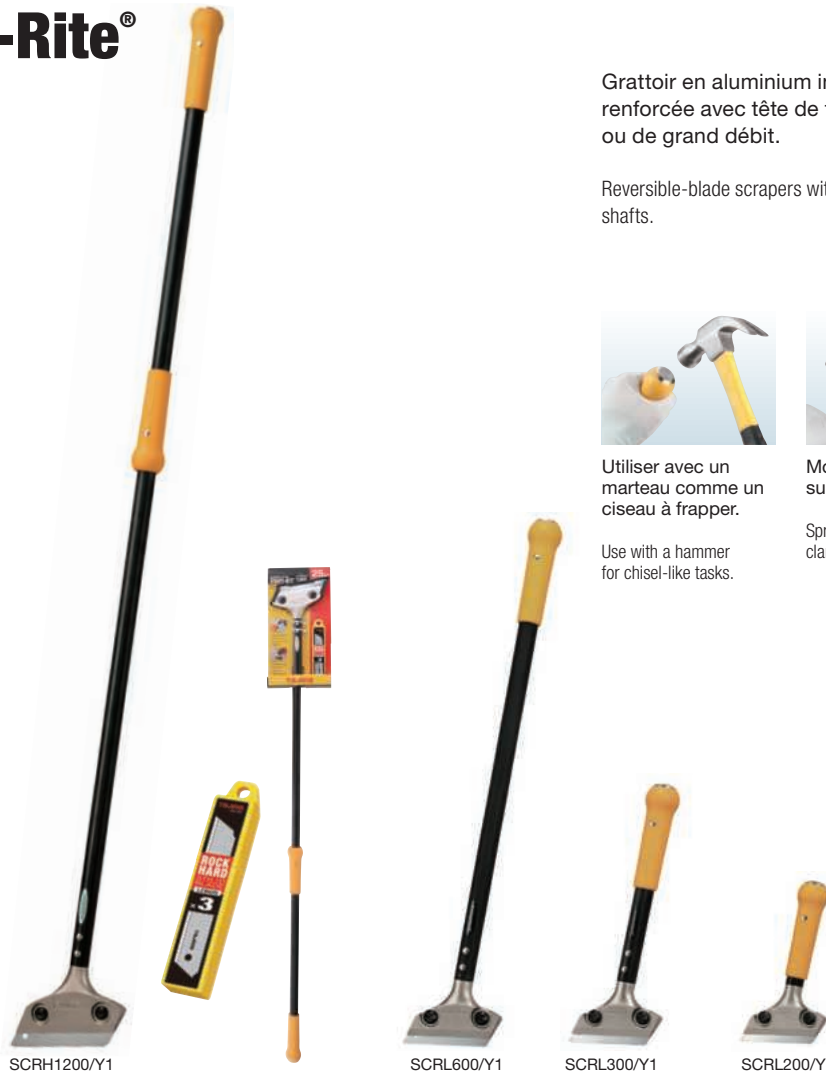

Grattoir en aluminium injecté à lame reversible, poignée renforcée avec tête de frappe, pour un travail de précision ou de grand débit.

Reversible-blade scrapers with die-cast aluminum heads and reinforced shafts.





Utiliser avec un marteau comme un ciseau à frapper.  
Use with a hammer for chisel-like tasks.



Montage de la lame sur ressort.  
Spring-loaded blade clamp.

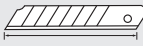

Protecteur de lame.  
Protective blade guard.

| Art.Nr.     |  |  | BLADE              | CASE | MASTER CARTON | EAN            | Weight (g) (Packaging + Product) |
|-------------|---|---|--------------------|------|---------------|----------------|----------------------------------|
| SCRL200/Y1  | 18 mm   | 3   | 18 mm ENDURA-BLADE | 4    | 24            | 4975364 016126 | 314                              |
| SCRL300/Y1  |   |   |                    |      |               | 4975364 016133 | 460                              |
| SCRL600/Y1  |   |   |                    |      |               | 4975364 016140 | 558                              |
| SCRH1200/Y1 | 25 mm   |   | 25 mm ENDURA-BLADE |      | 8             | 4975364 019967 | 1,220                            |

# SCIES A MAIN ET LAMES

## HAND SAWS & BLADES

### JAPAN PULL

Scie japonaise, coupe rapide et précise en tirant nécessitant moins de force.

Precision Pull-Stroke Saws That Cut Cleaner, Faster And With Less Effort.

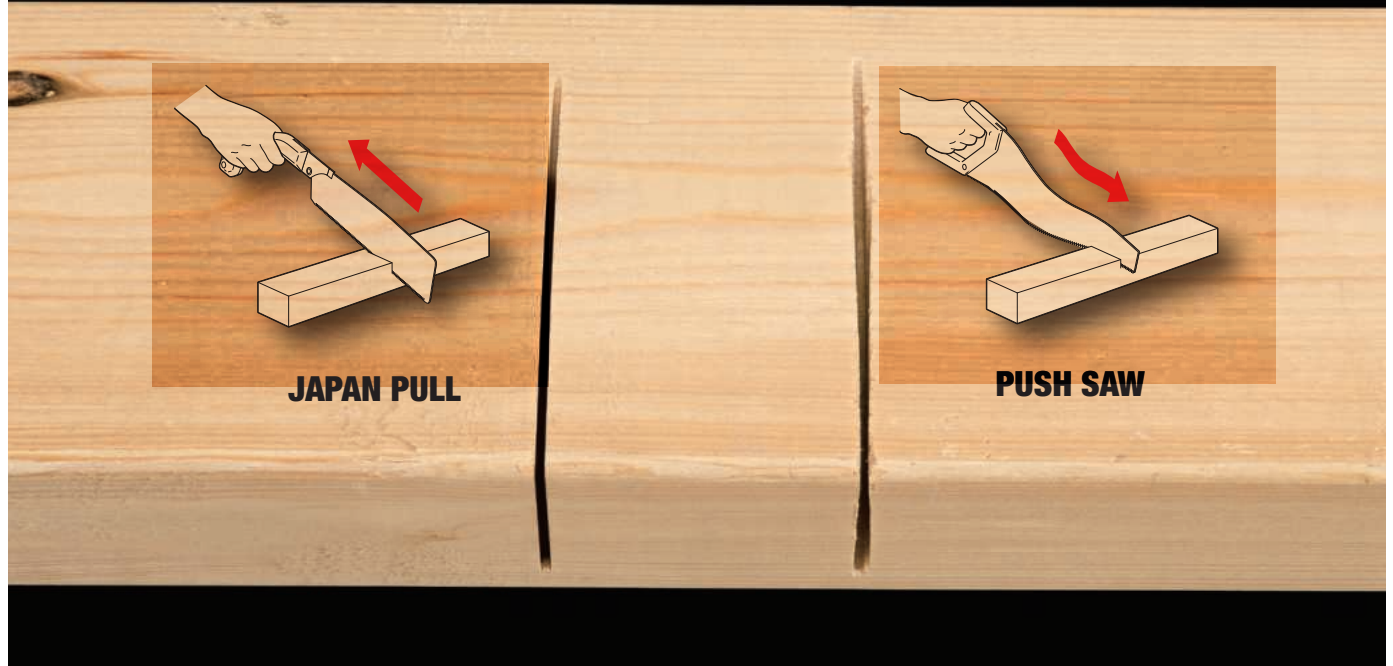

11



Lame japonaise en acier trempé SK95 de qualité supérieure, avec denture à triple angle de coupe et revêtement Fluoro-Coat.

Japanese tempered SK-95 premium steel blade with triple cutting edge teeth and Fluoro-Coat blade coating.



Lame japonaise en acier trempé SK95 de qualité supérieure, avec denture à triple angle de coupe.

Japanese tempered SK-95 premium steel blade with triple cutting edge teeth.



# SCIES A MAIN ET LAMES

## HAND SAWS & BLADES

### JAPAN PULL

#### Caractéristiques Des Lames

Blade Features



**Traitement de l'acier par choc thermique offrant une longévité exceptionnelle et un mordant longue durée.**

Unique steel hardening process that results in blades with exceptional durability and cutting performance.



**L'alternance de 4 grosses dents et de 4 dents plus petites multiplie par 3 la performance du tranchant de la lame.**

Alternating 4 tall, 4 short teeth pattern that results in cutting edge sharpness that lasts 3 times longer.

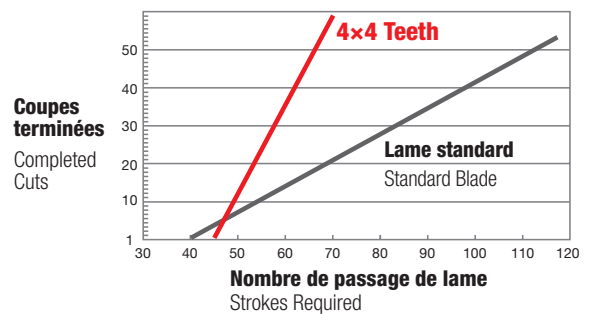

**Traitement de la denture par haute fréquence et choc thermique pour obtenir une performance de coupe de haut niveau tout en gardant la flexibilité de la lame.**

Spot hardening of blade teeth to further enhance the cutting performance while not reducing blade flexibility.



**Cette scie coupe tout, quelque soit l'épaisseur. Coupe bien droite. Un revêtement unique au fluor empêche le grippage et l'adhérence**

This crosscut saw eats through anything, thick or thin. Cuts through well and in a straight line. Unique fluorine coating prevents seizing and adherence of gum.



\*Les lames noires Fluoro-Coat et une lame standard après 100 coupes de branches d'une épaisseur de 40 mm.

\*After cutting through 40 mm thick branches, 100 times.



**Coupe précise sur toute la longueur grâce à la lame extra rigide.**

Extra rigid blade for superior tracking and cutting control.

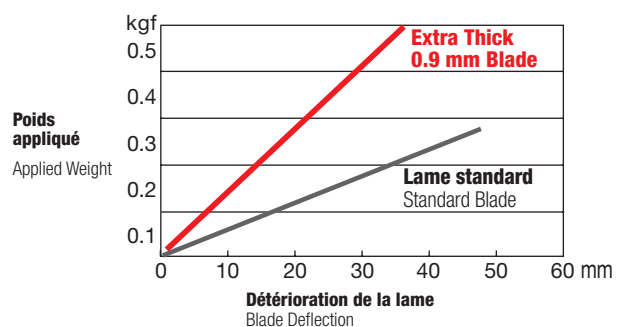

11

# SCIES A MAIN ET LAMES

## HAND SAWS & BLADES

### Japan Pull R-Saw

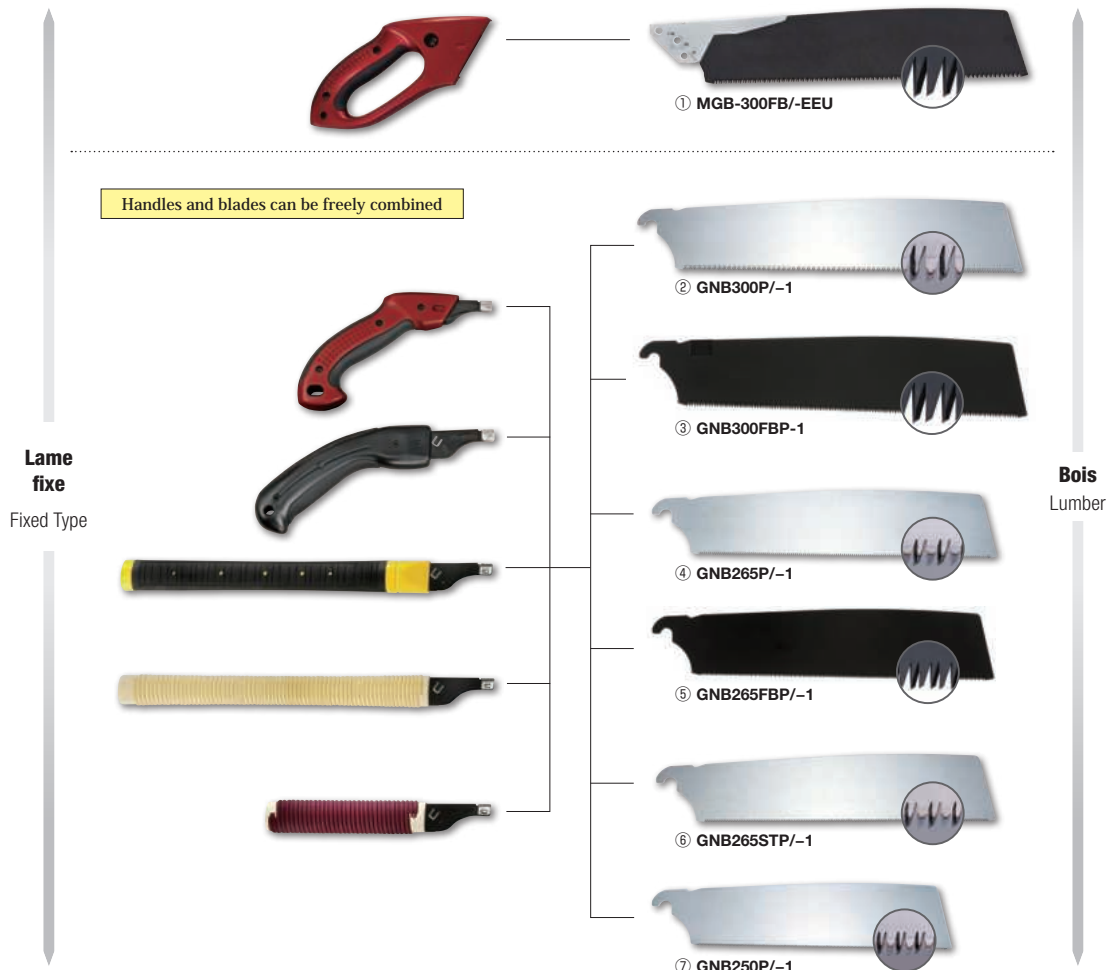

| Caractéristiques Des Lames<br>Blade Features |                                    | Materiaux adaptés<br>Material Suitability Index |         |                     |         |         |         |         |         |         |
|--|------------------------------------|---|---------|---------------------|---------|---------|---------|---------|---------|---------|
| Blade Features                               | Diagram                            | Diagram   | Diagram | Diagram             | Diagram | Diagram | Diagram | Diagram | Diagram | Diagram |
| ① MGB-300FB/-EEU                             | Coupe standard<br>Standard Cut     | 2.15 mm   | 13 TPI  | 0.7 mm<br>(1.15 mm) | —       | ★       | ★★      | ★★★     | ★★      | —       |
| ② GNB300P/-1                                 |                                    |   |         |                     |         |         |         |         |         |         |
| ③ GNB300FBP-1                                |                                    |   |         |                     |         |         |         |         |         |         |
| ④ GNB265P/-1                                 | Coupe fine<br>Fine Cut             | 1.75 mm   | 16 TPI  | 0.6 mm<br>(0.9 mm)  | —       | ★★      | ★★★     | ★★      | ★       | —       |
| ⑤ GNB265FBP/-1                               |                                    |   |         |                     |         |         |         |         |         |         |
| ⑥ GNB265STP/-1                               |                                    |   |         |                     |         |         |         |         |         |         |
| ⑦ GNB250P/-1                                 | Coupe extra-fine<br>Extra Fine Cut | 1.40 mm   | 19 TPI  | 0.5 mm<br>(0.7 mm)  | —       | ★★★     | ★★      | ★       | —       | —       |

# SCIES A MAIN ET LAMES

## HAND SAWS & BLADES

### Magnum



Scie japonaise de précision avec déblocage de lame rapide et poignée en alliage d'aluminium gainée en élastomère et protège lame.

Premium carpenter saw with a 13 TPI Fluoro-Coat blade and an oversize handle with an embedded elastomer grip and a protective blade guard that covers then entire blade.

| Art.Nr.      |        |         |        |                    | CASE | MASTER CARTON | EAN            | Weight ( g )<br>( Packaging + Product ) |
|--------------|--------|---------|--------|--------------------|------|---------------|----------------|---|
| MG300FB/REEU | 300 mm | 2.15 mm | 13 TPI | 0.7 mm ( 1.15 mm ) | 4    | 12            | 4975364 019028 | 530                                     |

### Japan Pull ALUMINIST®

Scie japonaise de précision avec déblocage de lame rapide et poignée en alliage d'aluminium gainée en élastomère et protège lame.

Precision pull-stroke saws with Quick-Release blade retainers, die cast aluminum handles with embedded elastomer grips and protective blade guards.



| Art.Nr.      |        |         |        |                    | CASE | MASTER CARTON | EAN            | Weight ( g )<br>( Packaging + Product ) |
|--------------|--------|---------|--------|--------------------|------|---------------|----------------|---|
| JPR265A/R1   | 265 mm | 1.75 mm | 16 TPI | 0.6 mm ( 0.9 mm )  | 6    | 24            | 4975364 110329 | 424                                     |
| JPR265AFB-R1 |        |         |        |                    |      |               | 4975364 112859 | 424                                     |
| JPR300A/R1   | 300 mm | 2.15 mm | 13 TPI | 0.7 mm ( 1.15 mm ) |      |               | 4975364 110336 | 554                                     |

### Japan Pull

Scie japonaise de précision à changement de lame rapide , poignée pistolet gainée en élastomère antidérapant.

Precision pull-stroke saws with Quick-Release blade retainers and curved handles with elastomer non-slip grips.



JPR265D/K1

| Art.Nr.    |        |         |        |                    | CASE | MASTER CARTON | EAN            | Weight ( g )<br>( Packaging + Product ) |
|------------|--------|---------|--------|--------------------|------|---------------|----------------|---|
| JPR265D/K1 | 265 mm | 1.75 mm | 16 TPI | 0.6 mm ( 0.9 mm )  | 6    | 24 ( 4 SETS ) | 4975364 019356 | 1,620 ( 204/pc )                        |
| JPR300/K1  | 300 mm | 2.15 mm | 13 TPI | 0.7 mm ( 1.15 mm ) |      | 60            | 4975364 019363 | 266                                     |

# SCIES A MAIN ET LAMES

## HAND SAWS & BLADES

### Japan Pull 265 Fluorine Black



Poignée en élastomère antidérapante, agréable au toucher.

Non-slip elastomer grip, soft on hands.

| Art.Nr.      |        |         |        |                   | CASE | MASTER CARTON | EAN            | Weight ( g )<br>( Packaging + Product ) |
|--------------|--------|---------|--------|-------------------|------|---------------|----------------|---|
| JPR265FBR/Y1 | 265 mm | 1.75 mm | 16 TPI | 0.6 mm ( 0.9 mm ) | 6    | 24            | 4975364 112538 | 230                                     |

### Japan Pull 265 Rubber Grip



Scie japonaise de précision à changement de lame rapide, poignée droite classique avec revêtement en élastomère.

Precision pull-stroke saw with a Quick-Release blade retainer and a traditional straight handle with elastomer grip.

| Art.Nr.    |        |         |        |                   | CASE | MASTER CARTON | EAN            | Weight ( g )<br>( Packaging + Product ) |
|------------|--------|---------|--------|-------------------|------|---------------|----------------|---|
| JPR265R/Y1 | 265 mm | 1.75 mm | 16 TPI | 0.6 mm ( 0.9 mm ) | 6    | 24            | 4975364 019707 | 230                                     |

### Japan Pull 265 Classic Grip



Scie japonaise de précision à changement de lame rapide, poignée droite classique avec revêtement en rotin.

Precision pull-stroke saw with a Quick-Release blade retainer and a traditional straight handle with rattan grip.

| Art.Nr.    |        |         |        |                   | CASE | MASTER CARTON | EAN            | Weight ( g )<br>( Packaging + Product ) |
|------------|--------|---------|--------|-------------------|------|---------------|----------------|---|
| JPR265C/-1 | 265 mm | 1.75 mm | 16 TPI | 0.6 mm ( 0.9 mm ) | 6    | 24            | 4975364 110299 | 180                                     |

# SCIES A MAIN ET LAMES





## HAND SAWS & BLADES

### Japan Pull 265 Short Grip



Scie japonaise de précision à changement de lame rapide, poignée type tube, droite et courte, avec revêtement en élastomère.

Precision pull-stroke saw with a Quick-Release blade retainer and a short straight handle with tubular elastomer grip.





| Art.Nr.     |  |  |  |  | CASE | MASTER CARTON | EAN            | Weight (g)<br>(Packaging + Product) |
|-------------|---|---|---|---|------|---------------|----------------|-------------------------------------|
| JPR265ST/-1 | 230 mm  | 1.75 mm   | 16 TPI  | 0.6 mm (0.9 mm)   | 6    | 24            | 4975364 110305 | 125                                 |

### Japan Pull Blade Fluorine Black



Cette scie à tronçonner coupe à travers tout, que ce soit épais ou mince. Coupe bien et en ligne droite. Un revêtement unique au fluor empêche le grippage et l'adhérence de la gomme..

This crosscut saw eats through anything, thick or thin. Cuts through well and in a straight line. Unique fluorine coating prevents seizing and adherence of gum.





| Art.Nr.      |  |  |  |  | CASE | MASTER CARTON | EAN            | Weight (g)<br>(Packaging + Product) |
|--------------|---|---|---|---|------|---------------|----------------|-------------------------------------|
| GNB265FBP/-1 | 265 mm  | 1.75 mm   | 16 TPI  | 0.6 mm (0.9 mm)   | 12   | 120           | 4975364 112545 | 96                                  |

### Japan Pull Blades



Lame de première qualité avec denture à trois angles de coupe en acier trempé par haute fréquence, pour une performance de coupe exceptionnelle.

Premium-grade blades with triple-edge cutting teeth impulse hardened for superior performance.

| Art.Nr.      |  |  |  |  | CASE | MASTER CARTON | EAN            | Weight (g)<br>(Packaging + Product) |
|--------------|---|---|---|---|------|---------------|----------------|-------------------------------------|
| GNB250P/-1   | 250 mm  | 1.40 mm   | 19 TPI  | 0.5 mm (0.7 mm)   | 24   | 120           | 4975364 060013 | 56                                  |
| GNB265STP/-1 | 230 mm  | 1.75 mm   | 16 TPI  | 0.6 mm (0.9 mm)   |      |               | 4975364 015792 | 60                                  |
| GNB265P/-1   | 265 mm  |   |   |   |      |               | 4975364 060037 | 70                                  |
| GNB300P/-1   | 300 mm  | 2.15 mm   | 13 TPI  | 0.7 mm (1.15 mm)  |      |               | 4975364 060099 | 100                                 |

# SCIES A MAIN ET LAMES

## HAND SAWS & BLADES

### Japan Pull G-Saw

Toutes les poignées sont interchangeables avec toutes les lames.

All handles are interchangeable with all blades.

Handles and blades can be freely combined

Scie pliable  
Folding Handle



Lame fixe  
Fixed Handle



① GKBG210 / GKBG240

② ALB-A210FB / ALB-A240FB

Bois  
Lumber

11

| Caractéristiques Des Lames<br>Blade Features |          |                                    |         |       | Matériaux adaptés<br>Material Suitability Index |    |   |     |     |    |   |   |
|--|----------|------------------------------------|---------|-------|---|----|---|-----|-----|----|---|---|
|  |          |                                    |         |       |   |    |   |     |     |    |   |   |
| ① GKBG210 / GKBG240                          | <br>     | Coupe aggressive<br>Aggressive Cut | 3.00 mm | 9 TPI | 0.7 mm (1.0 mm)                                 | ★★ | — | ★★  | ★★★ | ★★ | — | — |
| ② ALB-A210FB / ALB-A240FB                    | <br><br> |                                    |         |       | 0.8 mm (1.1 mm)                                 | ★★ | — | ★★★ | ★★  | —  | — |   |
|  | <br>     |                                    |         |       | 0.9 mm (1.2 mm)                                 |    |   |     |     |    |   |   |

# SCIES A MAIN ET LAMES

## HAND SAWS & BLADES

### ALUMINIST® Power-Glide Folding Handle



ALOR-A240FB-EU

Scie pliable, poignée en alliage aluminium gainée en élastomère et lame 9 TPI Fluoro-Coat.

Die-cast aluminum folding handle saws with elastomer grips and tapered 9 TPI Fluoro-Coat blades.



Deux positions d'ouverture  
Pour dégager la main au-dessus des surfaces à couper.

Two-Position Blade Fold-Out  
For positioning the hand even with or above the cutting surface.

| Art.Nr.        |        |        |       |                   | CASE | MASTER CARTON | EAN            | Weight ( g )<br>( Packaging + Product ) |
|----------------|--------|--------|-------|-------------------|------|---------------|----------------|---|
| ALOR-A210FB-EU | 210 mm | 3.0 mm | 9 TPI | 0.9 mm ( 1.2 mm ) | 4    | 24            | 4975364 017819 | 220                                     |
| ALOR-A240FB-EU | 240 mm |        |       |                   |      |               | 4975364 017826 | 255                                     |

### ALUMINIST® Power-Glide Sheath



ALSA-A240FB-EU

Scie à poignée pistolet en alliage aluminium gainée en élastomère, lame trempée 9 TPI Fluoro-Coat et protège lame.

Die-cast aluminum curved handle saws with elastomer grips, tapered 9 TPI Fluoro-Coat blades and protective sheaths.

| Art.Nr.        |        |        |       |                   | CASE | MASTER CARTON | EAN            | Weight ( g )<br>( Packaging + Product ) |
|----------------|--------|--------|-------|-------------------|------|---------------|----------------|---|
| ALSA-A210FB-EU | 210 mm | 3.0 mm | 9 TPI | 0.9 mm ( 1.2 mm ) | 4    | 24            | 4975364 017772 | 280                                     |
| ALSA-A240FB-EU | 240 mm |        |       |                   |      |               | 4975364 017789 | 290                                     |

# SCIES A MAIN ET LAMES

## HAND SAWS & BLADES

### G-Saw 210 / 240

4x4  
TEETH







GKG240B/K1

Scie pliable, poignée gainée en élastomère et lame trempée 9 TPI pour un usage polyvalent.

Folding handle saws with elastomer grips and tapered 9 TPI multipurpose blades.

11

| Art.Nr.    |  |  |  |  | CASE | MASTER CARTON | EAN            | Weight (g)<br>(Packaging + Product) |
|------------|---|---|---|---|------|---------------|----------------|-------------------------------------|
| GKG210B/K1 | 210 mm  | 3.0 mm  | 9 TPI   | 0.7 mm ( 1.0 mm )   | 6    | 60            | 4975364 015754 | 238                                 |
| GKG240B/K1 | 240 mm  |   |   |   |      |               | 4975364 015891 | 265                                 |

### G-Saw Blade Fluorine Black

FLUORO COAT  
BLADE

4x4  
TEETH





Extra Thick  
0.9mm



ALB-A240FB

Lame de première qualité 9 TPI en acier trempé avec revêtement Fluoro-Coat.

Premium-grade 9 TPI tapered blades with Fluoro-Coat blade coating.

| Art.Nr.    |  |  |  |  | CASE | MASTER CARTON | EAN            | Weight (g)<br>(Packaging + Product) |
|------------|---|---|---|---|------|---------------|----------------|-------------------------------------|
| ALB-A210FB | 210 mm  | 3.0 mm  | 9 TPI   | 0.9 mm ( 1.2 mm )   | 12   | 120           | 4975364 017482 | 46                                  |
| ALB-A240FB | 240 mm  |   |   |   |      |               | 4975364 017499 | 53                                  |

# SCIES A MAIN ET LAMES

## HAND SAWS & BLADES

### G-Saw Blades





4x4  
TEETH

Lame de première qualité 9 TPI en acier trempé.

Premium-grade 9 TPI tapered blades.



GKBG240/-1

| Art.Nr.    |  |  |  |  | CASE | MASTER CARTON | EAN            | Weight (g)<br>(Packaging + Product) |
|------------|---|---|---|---|------|---------------|----------------|-------------------------------------|
| GKBG210/-1 | 210 mm  | 3.0 mm  | 9 TPI   | 0.7 mm ( 1.0 mm )   | 12   | 120           | 4975364 015761 | 36                                  |
| GKBG240/-1 | 240 mm  |   |   |   |      |               | 4975364 015907 | 41                                  |

# SCIES A MAIN ET LAMES

## HAND SAWS & BLADES

### GT-Saw



11

### GT-Flush Cut Saw







N-G165FS-EUR

- Coupe de précision extra fine
- Gainage élastomère anti-glisse et confortable
- Denture extra fine pour couper à ras sans les surfaces proches

- Extra fine and precision cutting
- Elastomer grip for non-slip gripping and comfort
- Rip cut saw teeth can cut flush without damaging surrounding surfaces.



| Art.Nr.       |  |  |  |  | CASE | MASTER CARTON | EAN            | Weight ( g )<br>( Packaging + Product ) |
|---------------|---|---|---|---|------|---------------|----------------|---|
| N-G165FS-EUR  | 165 mm  | 0.95 mm   | 27 TPI  | 0.3 mm ( 0.3mm )  | 12   | 72            | 4975364 112941 | 190                                     |
| NK-G165FS-EUR |   |   |   |   | 24   | 120           | 4975364 112958 | 30                                      |

# SCIES A MAIN ET LAMES

## HAND SAWS & BLADES

### GT Jab-Saw



N-G165JS-K1





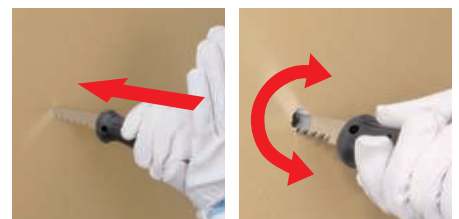

Scie à lame pointue, renforcée d'acier, dotée d'une poignée ergonomique en élastomère et d'une lame remplaçable extra-robuste de 1,2 mm d'épaisseur avec deux rangées de dents de coupe tranchantes.

Unique, steel-reinforced jab saw that features an ergonomic elastomer handle and a replaceable extra heavy-duty 1.2 mm thick blade with twin rows of razor-sharp cutting teeth.



Pousser à travers la cloison sèche pour effectuer une coupe

Push it through the drywall and make a rough cut

| Art.Nr.     |  |  |  |  | CASE | MASTER CARTON | EAN            | Weight ( g )<br>( Packaging + Product ) |
|-------------|---|---|---|---|------|---------------|----------------|---|
| N-G165JS-K1 | 165 mm  | 3.75 mm   | 7 TPI   | 1.8 mm ( 2.1mm )  | 12   | 72            | 4975364 112705 | 143                                     |
| NK-G165JS-1 |   |   |   |   | 24   | 120           | 4975364 112712 | 32                                      |

# PISTOLETS POUR CARTOUCHES A MASTIC CAULK GUNS

## CONVOY®

Pistolets pour cartouche à mastic souple et fiable, avec poignée rotative pour accéder dans et autour des espaces étroits, corps extra-long pour une recharge facile des cartouches, et offrant un système de forte démultiplication en option pour travailler aisément avec n'importe quel type de matière.

Smooth and dependable caulk guns with rotating handles for maneuvering in and around tight spaces, extra-long barrels for hassle-free tube reloads, and featuring thrust system options to handle any material with ease.



12

## Système de poussée / Thrust System

### DP Dual Power

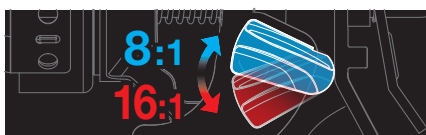

Pour les matières visqueuses, baisser le levier, pour les matières moins dures, relever le levier. En baissant le levier la force de la poussée augmente d'environ 40%.

For hard materials, pull down the lever, for soft materials, push up the lever. By pulling down the lever, thrust force increases about 40%.

### Enhanced SST Enhanced SST



En augmentant de 20% le contact entre le poussoir et la plaque, la force d'extrusion est transmise pleinement. Ceci améliorant la longévité.

By increasing 20% of contact surface between plunger and valve plate, the thrust force is transmitted to the plunger without reduction. This results in higher durability.

### TT System Twin Thrust System

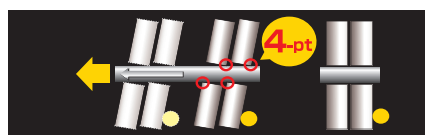

Les 4 bords de la plaque augmentent la force d'extrusion du poussoir. Une aide pour extruder les matières très visqueuses.

4 edges of valve plates strengthen the thrust force on the plunger. It helps to use hard materials with ease.

## Fonctions / Functions

### 360° RH 360° Rotating Handle

Pour une utilisation dans les espaces réduits.

For maneuvering in and around tight spaces.



### AFS System Auto Flow Stop System

Le poussoir se rétracte de quelques millimètres après chaque poussée pour stopper efficacement et rapidement l'écoulement.















Plunger goes back a few millimeters after every push to stop the flow efficiently and quickly.



# PISTOLETS POUR CARTOUCHES A MASTIC

## CAULK GUNS

### Liste des fonctions / Function List

| Fiche technique et fonctions<br>Specifications and Functions   | Matériaux d'étanchéité<br>Caulking material sizes   | Matériau<br>Materials          |                        | Système de poussée<br>Thrust System | Fonctions<br>Functions |
|--|---|--------------------------------|------------------------|-------------------------------------|------------------------|
|  |   | Corps<br>Barrels               | Poignées<br>Grips      |                                     |                        |
| <b>CONVOY® Bulk Super 3Way</b><br><br><br>P82     |  En seau : capacité 550 ml<br>Pail = up to 550 ml      | Aluminium<br>aluminium         | Enhanced<br><b>SST</b> | —                                   |                        |
|  |  Poche = jusqu'à 400 ml<br>Sausage pack = up to 400 ml |                                |                        |                                     |                        |
|  |  Cartouche = 330 ml<br>Cartridge = 330 ml              |                                |                        |                                     |                        |
| <b>CONVOY® Super Sausage 2way</b><br><br><br>P82 |  Poche = jusqu'à 600 ml<br>Sausage pack = up to 600 ml | Métal/ Résine<br>Metal / Resin | TT<br>System           | AFS<br>System                       |                        |
|  |  Cartouche = 300 ml<br>Cartridge = 300 ml            |                                |                        |                                     |                        |
| <b>CONVOY® RS</b><br><br><br>P83                | Cartouche = 310 ml<br>Cartridge = 310 ml  | Métal<br>Metal                 | DP Enhanced<br>SST     | 360°<br>RH                          |                        |
| <b>CONVOY® Super 26</b><br><br><br>P83          | <b>CNV100SP26/R1</b><br>Cartouche = 310 ml<br>Cartridge = 310ml<br><br><b>CNV900SP26-R1</b><br>Cartouche = 900 ml<br>Cartridge = 900 ml |                                |                        |                                     |                        |
| <b>CONVOY® Super 12</b><br><br><br>P84          | Cartouche = 310 ml<br>Cartridge = 310 ml  | Métal /Résine<br>Metal / Resin | Enhanced<br><b>SST</b> | —                                   |                        |
| <b>CONVOY® Just</b><br><br><br>P84              |   |                                |                        |                                     |                        |
| <b>CONVOY® J900</b><br><br><br>P85              |  Cartouche = 900 ml<br>Cartridge = 900 ml            | Résine<br>Resin                | TT<br>System           | AFS<br>System                       |                        |
| <b>CONVOY® Lite</b><br><br><br>P85              |  Cartouche = 310 ml<br>Cartridge = 310 ml            |                                |                        |                                     |                        |

# PISTOLETS POUR CARTOUCHES A MASTIC

## CAULK GUNS

### CONVOY® Bulk Super 3Way

Enhanced SST 360° RH



#### Accessoires standards

Standard accessories

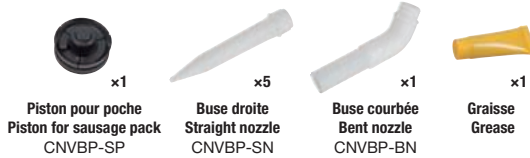

Pistolet extrudeur Triple Usage: vrac en seau, poche, cartouche. Changement de piston facile en appuyant sur la bille selon l'utilisation. Système SST pour les matières à viscosité élevée. Poignée et gachette haute résistance en aluminium moulé. Un joint caoutchouc assure une parfaite étanchéité. Equipé d'un mécanisme anti-goutte.

3way caulking gun with three refill types: bulk, sausage pack and cartridge. Just touch a button to switch to the right piston for your refill type. SST system makes it easy to use high-viscosity materials. Durable die-cast aluminum trigger and grip. A rubber gasket on the piston ensures that no caulking material leaks back into the gun. Fitted with a drip-prevention mechanism.

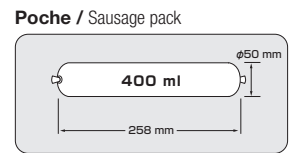
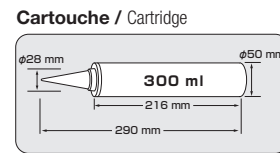

| Art.Nr.        |        |        |        |                  | FEATURES            | CASE | MASTER CARTON | EAN            | Weight (g) (Packaging + Product) |
|----------------|--------|--------|--------|------------------|---------------------|------|---------------|----------------|----------------------------------|
| CNVBSP3W550/R1 | 10 : 1 | 300 ml | 400 ml | Up to 550 ml max | Enhanced SST System | 1    | 4             | 4975364 260192 | 1,280                            |

### CONVOY® Super Sausage 2way

TT System 360° RH AFS System



#### Accessoires standards

Standard accessories

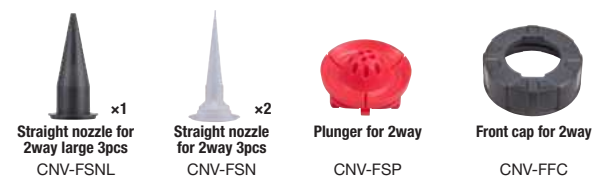

- Compatible pour les poches et les cartouches
- Piston amovible
- La conception du bouchon avant permet l'extrusion totale de matière du tube
- Pas de résidu sur surface

- Compatible with sausage and cartridge refills
- Removable plunger
- Uniquely designed front cap enables every ounce of material to be released from the tube
- Anti-residue surface

#### Quick Plunger



#### Twin-Thrust System

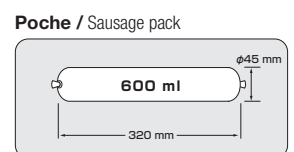
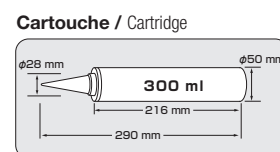

| Art.Nr.       |        |        |        | FEATURES      | CASE | MASTER CARTON | EAN            | Weight (g) (Packaging + Product) |
|---------------|--------|--------|--------|---------------|------|---------------|----------------|----------------------------------|
| CNV-FSP600-R1 | 12 : 1 | 300 ml | 600 ml | QUICK PLUNGER | 4    | 16            | 4975364 266422 | 1,060                            |

# PISTOLETS POUR CARTOUCHES A MASTIC CAULK GUNS

## CONVOY® RS

**DP** **Enhanced SST** **360° RH**

Pistolet à force d'extrusion réglable, corps extra long, rotatif à 360°, pointe pour déboucher les buses durcies. Pour les cartouches de matières épaisses et visqueuses.

Switchable thrust force caulk gun with extra-long barrels, 360° rotating handles, and extra-long seal puncture pins. For dispensing thick, viscous materials.

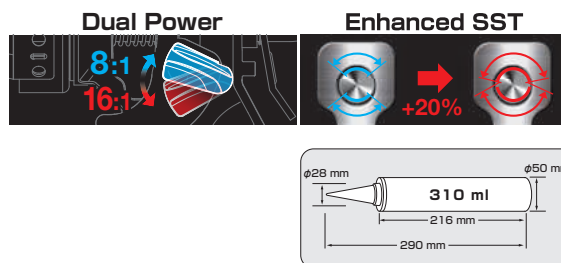

| Art.Nr.     |                 |        | FEATURES                          | CASE | MASTER CARTON | EAN            | Weight ( g )<br>( Packaging + Product ) |
|-------------|-----------------|--------|-----------------------------------|------|---------------|----------------|---|
| CNV100RS/B1 | 8 : 1<br>16 : 1 | 310 ml | Dual Power<br>Enhanced SST System | 6    | 24            | 4975364 168559 | 760                                     |

## CONVOY® Super 26

**Enhanced SST** **360° RH**

Pistolets pour cartouche à mastic avec puissance d'extrusion fortement démultipliée et un corps extra-long, poignée rotative à 360° gainée en élastomère anti glisse, et pointe extra longue pour déboucher. Idéal pour les matières très épaisses et visqueuses.

Extra-high thrust caulk guns with extra-long barrels, 360° rotating handles with elastomer non-slip grips, and extra-long seal puncture pins. For dispensing extra-thick, viscous materials.

CNV100SP26/R1



CNV900SP26-R1

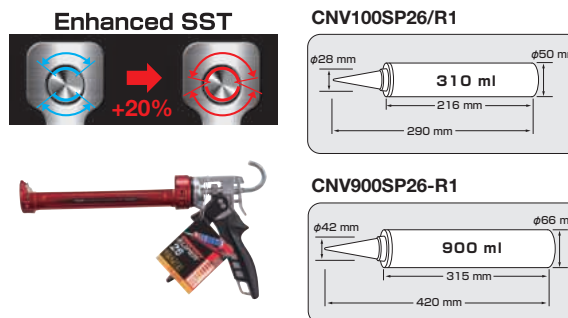

| Art.Nr.       |        |        | FEATURES            | CASE | MASTER CARTON | EAN            | Weight ( g )<br>( Packaging + Product ) |
|---------------|--------|--------|---------------------|------|---------------|----------------|---|
| CNV100SP26/R1 | 26 : 1 | 310 ml | Enhanced SST System | 6    | 24            | 4975364 165619 | 900                                     |
| CNV900SP26-R1 |        | 900 ml |                     | 4    | 16            | 4975364 165633 | 1,005                                   |

# PISTOLETS POUR CARTOUCHES A MASTIC

## CAULK GUNS

### CONVOY® Super 12



Avec son système de transmission Twin Thrust puissant et sa poignée tournant à 360°, ce pistolet pour cartouche de mastic à corps extra-long garantit une performance optimale.

Max performance caulk gun with an extra-long barrel, a powerful Twin Thrust dispensing system, Auto Flow Stop, and a 360° rotating handle.

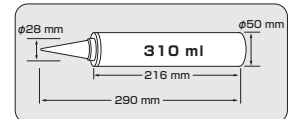
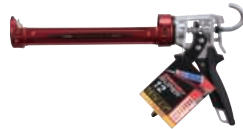

| Art.Nr.       |        |        | FEATURES           | CASE | MASTER CARTON | EAN            | Weight (g)<br>(Packaging + Product) |
|---------------|--------|--------|--------------------|------|---------------|----------------|-------------------------------------|
| CNV100SP12/R1 | 12 : 1 | 310 ml | Twin Thrust System | 6    | 24            | 4975364 067302 | 820                                 |

### CONVOY® Just



Pistolet pour cartouche de mastic, corps extra-long, tournant à 360°.

Doté d'un double système de transmission.

Extra-long barrel caulk gun with a powerful Twin Thrust dispensing system, Auto Flow Stop, and a 360° rotating handle.

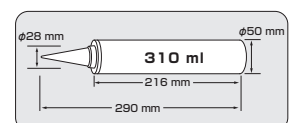

| Art.Nr.     |       |        | FEATURES           | CASE | MASTER CARTON | EAN            | Weight (g)<br>(Packaging + Product) |
|-------------|-------|--------|--------------------|------|---------------|----------------|-------------------------------------|
| CNV-JUST/Y1 | 7 : 1 | 310 ml | Twin Thrust System | 6    | 24            | 4975364 066954 | 600                                 |

# PISTOLETS POUR CARTOUCHES A MASTIC CAULK GUNS

## CONVOY® J900



Pistolet pour cartouche de mastic, corps extra- long, tournant à 360°. Doté d'un double système de transmission, destiné aux cartouches de grande taille.

Extra-long barrel caulk gun for large size tubes that features a powerful Twin Thrust dispensing system, Auto Flow Stop, and a 360° rotating handle.

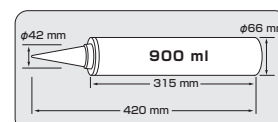

| Art.Nr.       |       |                     | FEATURES           | CASE | MASTER CARTON | EAN                 | Weight ( g )<br>( Packaging + Product ) |
|---------------|-------|---------------------|--------------------|------|---------------|---------------------|---|
| CNVJ900/YEUSA | 7 : 1 | US QUART ( 900 ml ) | Twin Thrust System | 4    | 16            | 049296065911( UPC ) | 900                                     |

## CONVOY® Lite



Pistolet pour cartouche de mastic ultra-léger, doté d'un système unique de dégagement du corps par déverrouillage rotatif pour effectuer des échanges rapides et faciles de la cartouche.

Ultra-light caulk gun with a unique twist-lock barrel removal system for fast and easy tube changes, a powerful Twin Thrust dispensing system, and Auto Flow Stop.

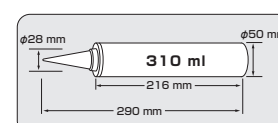

| Art.Nr.     |       |        | FEATURES           | CASE | MASTER CARTON | EAN            | Weight ( g )<br>( Packaging + Product ) |
|-------------|-------|--------|--------------------|------|---------------|----------------|---|
| CNV100LT/K1 | 7 : 1 | 310 ml | Twin Thrust System | 6    | 24            | 4975364 066282 | 480                                     |

# OUTILS DIVERS

## MARKING TOOLS

### Precision Snap Line Systems



13

| Line Thickness               |  <b>1.0 mm</b>  |  <b>1.8 mm</b> |  <b>2.8 mm</b> |
|------------------------------|--|---|---|
| Line Length                  |  |   |   |
| <b>45 m</b>                  | /  |   | CR604S-D1<br>  |
| <b>30 m</b>                  | CR301 JF/D1<br> | CR201 R-D1<br> | CR401 S/D1<br>   |
|                              | /  |   | CR503S-D1<br>    |
| <b>Replacement Snap Line</b> | PLITOL-EUR<br>  | PLITOLL-1<br> | PL-ITO3L-1<br> |

# OUTILS DIVERS

## MARKING TOOLS

### CHALK-RITE® Dura III



Integrated handle release  
Die-cast aluminum Case



- Corde spécialement tressée offrant
- Bouchon de recharge sur dimensionné et étanche
- Corps ergonomique résistant aux chocs avec sa plaque frontale en aluminium
- Rembobinage rapide à double vitesse
- Specially crafted woven snap line
- Large, leak-proof refill port
- Ergonomically designed shock-resistant case
- Double-speed winding mechanism

| Art.Nr.   | LINE LENGTH   | POWDER CAPACITY | CASE | MASTER CARTON | EAN            | Weight (g)<br>(Packaging + Product) |
|-----------|---------------|-----------------|------|---------------|----------------|-------------------------------------|
| CR604S-D1 | 2.8 mm × 45 m | 709g            | 1    | 12            | 4975364 058706 | 880                                 |

### CHALK-RITE® Dura II



Integrated handle release  
Die-cast aluminum Case



- Cordeau tressé de qualité
- Rembobinage rapide à double vitesse
- Premium braided snap line
- Double-speed winding mechanism

| Art.Nr.   | LINE LENGTH   | POWDER CAPACITY | CASE | MASTER CARTON | EAN            | Weight (g)<br>(Packaging + Product) |
|-----------|---------------|-----------------|------|---------------|----------------|-------------------------------------|
| CR503S-D1 | 1.8 mm × 30 m | 80g             | 4    | 24 (6 sets)   | 4975364 058690 | 1,660 (345/pc)                      |

### CHALK-RITE® Dura



Integrated handle release  
Die-cast aluminum Case



- Cordeau tressé de qualité
- Rembobinage rapide à double vitesse
- Premium braided snap line
- Double-speed winding mechanism

| Art.Nr.   | LINE LENGTH   | POWDER CAPACITY | CASE | MASTER CARTON | EAN            | Weight (g)<br>(Packaging + Product) |
|-----------|---------------|-----------------|------|---------------|----------------|-------------------------------------|
| CR401S/D1 | 1.0 mm × 30 m | 60g             | 4    | 24 (6 sets)   | 4975364 057402 | 1,480 (300/pc)                      |

# OUTILS DIVERS

## MARKING TOOLS

### CHALK-RITE® Gear Drive



Smooth and durable  
Die-cast aluminum Case



- Cordeau tressé premium
- Mécanisme souple de rembobinage 5 vitesses
- Premium braided snap line
- Smooth-running five-gear winding mechanism

| Art.Nr.   | LINE LENGTH   | POWDER CAPACITY | CASE | MASTER CARTON | EAN            | Weight ( g )<br>( Packaging + Product ) |
|-----------|---------------|-----------------|------|---------------|----------------|---|
| CR201R-D1 | 1.0 mm × 30 m | 55g             | 4    | 24 ( 6 sets ) | 4975364 058959 | 1,320 ( 260/pc )                        |

### CHALK-RITE® Jam Free



Smooth and durable  
ABS CASE



- Cordeau tressé anti nœuds
- Jam-Free braided line

| Art.Nr.    | LINE LENGTH   | POWDER CAPACITY | CASE | MASTER CARTON | EAN            | Weight ( g )<br>( Packaging + Product ) |
|------------|---------------|-----------------|------|---------------|----------------|---|
| CR301JF/D1 | 1.0 mm × 30 m | 70g             | 4    | 24 ( 6 sets ) | 4975364 057136 | 1,880 ( 200/pc )                        |

### CHALK-RITE® Snap Line



Cordeau de rechange pour cordeau traceur à poudre Chalk-Rite, tressé en nylon/polyester de première qualité.

Premium braided nylon / polyester lines for Chalk-Rite chalk snap lines.



|                       |  |
|-----------------------|--|
| Maximum Bold<br>2.8mm |  |
| Extreme Bold<br>1.8mm |  |
| Extra Bold<br>1.0mm   |  |
| Ultra-thin<br>0.5mm   |  |

| Art.Nr.    | LINE LENGTH   | FEATURES     | CASE | MASTER CARTON | EAN                  | Weight ( g )<br>( Packaging + Product ) |
|------------|---------------|--------------|------|---------------|----------------------|---|
| PL-ITO3L-1 | 2.8 mm × 45 m | Maximum Bold | 1    | 20            | 4975364 058720       | 230                                     |
| PLITOLL-1  | 1.8 mm × 30 m | Extreme Bold | 10   | 100           | 4975364 058713       | 46                                      |
| PLITOL-EUR | 1.0 mm × 30 m | Extra Bold   |      |               | 049296054359 ( UPC ) | 23                                      |
| PLITOS-EUR | 0.5 mm × 30 m | Ultra Thin   |      |               | 049296054342 ( UPC ) | 19                                      |

# OUTILS DE PLAQUISTES

## DRYWALL TOOLS

### Drywall Beveling Tools



S'utilise avec des lames de 18 mm de largeur.

Uses 18 mm / 3/4" wide blades.

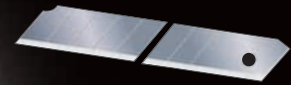

4 positions d'ajustement du chanfrein, de 1 mm à 3 mm.  
4-step bevel depth adjustment from 1 mm to 3 mm.

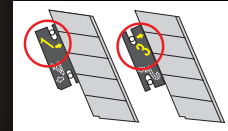

Réglages de la plaque d'ajustement du chanfrein.  
Blade Depth Adjustment Plate Settings.

| Nr. | 1      | 2      | 3      | 4      |
|-----|--------|--------|--------|--------|
|     | 1.0 mm | 1.5 mm | 2.0 mm | 3.0 mm |

Revêtement Fluoro-Coat pour un rabotage régulier. Corps en alliage d'aluminium robuste.

Fluoro-Coat base for smooth operation. Rugged die-cast aluminum core.

14

### Drywall Beveling Tools 120 / 180

Ce rabot à chanfreiner réglable pour cloisons sèches s'utilise avec des lames de 18 mm de largeur.

Adjustable bevel depth drywall plane uses 18 mm wide blades.



TBK180H45/R1



TBK120H45/R1



Accessoires

- Une lame Endura Blade 18 mm
- Outil de calibration de lame

Accessoires

- One 18 mm Endura Blade
- Blade Resizing Tool

**Dual-purpose**

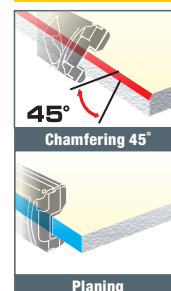

| Art.Nr.      |        |           | CASE | MASTER CARTON | EAN            | Weight ( g )<br>( Packaging + Product ) |
|--------------|--------|-----------|------|---------------|----------------|---|
| TBK120H45/R1 | 120 mm | max 15 mm | 6    | 36            | 4975364 056603 | 130                                     |
| TBK180H45/R1 | 180 mm |           |      |               | 4975364 056610 | 240                                     |

# OUTILS DE PLAQUISTES

## DRYWALL TOOLS

### Combination Drywall Rasp

**Tetra-Teeth**

Trois types de rapes sur la semelle  
Three grinding sections

- 1 Denture Latérale / Sideral Teeth
- 2 Denture fine / Fine Teeth
- 3 Grosse denture / Coarse Teeth

Anti-bourre à double action  
Clog-free dual-action

Récupération de la poussière dans la poignée  
In-handle dust collection

14

### Combination Drywall Rasp



Rape pour cloisons sèches Tetra Teeth anti-bourre et double action.

Clog-free dual-action Tetra Teeth drywall rasp.

| Art.Nr.    |        |             | CASE | MASTER CARTON | EAN            | Weight ( g )<br>( Packaging + Product ) |
|------------|--------|-------------|------|---------------|----------------|---|
| TBYD180/-1 | 180 mm | max 25.4 mm | 6    | 36            | 4975364 056665 | 180                                     |

# Angle Meter Slant



## Slant 100 / AL200M



SLT100/-E



SLTAL200M/K1



Rapporteur d'angle, équipé d'une échelle double, permet la mesure d'une pente ou d'un angle d'une seule main.

Rotating dual scale angle meters provide one-hand measurement of slant or angles.



SLTAL200M/K1

Avec aimant et cadre aluminium  
With magnet and aluminum frame

| Art.Nr.      |  | ACCURACY | SCALE SPECIFICATIONS | CASE | MASTER CARTON | EAN            | Weight ( g )<br>( Packaging + Product ) |
|--------------|---|----------|----------------------|------|---------------|----------------|---|
| SLT100/-E    | 130° - 0 - 130°   | ±1°      | 2°                   | 6    | 36            | 4975364 040831 | 275                                     |
| SLTAL200M/K1 |   |          |                      |      |               | 4975364 065858 | 460                                     |

# FILS A PLOMB

## LAYOUT TOOLS

### Layout Tools

# PLUMB-RITE®





## PLUMB-RITE® 400GP

Fil à plomb à retour automatique, avec boîtier en élastomère, livré avec une tête de cheville renforcée et un plomb de 400 g à stabilisation très rapide.

All-in-one plumb alignment and centering tool with a self-retracting line, elastomer-wrapped case, reinforced setting pin head and a 400 g / 14 oz Quick Stabilizing bob.



| Art.Nr.      |  |  | CASE | MASTER CARTON | EAN            | Weight ( g )<br>( Packaging + Product ) |
|--------------|---|---|------|---------------|----------------|---|
| PZB400GPY/D1 | 400 g   | 1.2 mm x 4.5 m  | 6    | 24 ( 4 sets ) | 4975364 055088 | 4,800 ( 750/pc )                        |

# FILS A PLOMB

## LAYOUT TOOLS

### PLUMB-RITE® 400

Fil à plomb à retour automatique, livré avec un plomb de 400 g à stabilisation très rapide.

All-in-one plumb alignment and centering tool with a self-retracting line and a 400 g / 14 oz Quick Stabilizing bob.



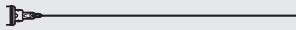

| Art.Nr.    |  |  | CASE | MASTER CARTON | EAN            | Weight (g)<br>(Packaging + Product) |
|------------|---|---|------|---------------|----------------|-------------------------------------|
| PZB400Y/D1 | 400 g   | 1.2 mm x 4.5 m  | 6    | 24 (4 sets)   | 4975364 055071 | 4,600 (710/pc)                      |

### PLUMB-RITE® 300

Fil à plomb à retour automatique, livré avec un plomb de 300 g à stabilisation très rapide.

All-in-one plumb alignment and centering tool with a self-retracting line and a 300 g / 10 oz Quick Stabilizing bob.



| Art.Nr.    |  |  | CASE | MASTER CARTON | EAN            | Weight (g)<br>(Packaging + Product) |
|------------|---|---|------|---------------|----------------|-------------------------------------|
| PZB300Y/D1 | 300 g   | 0.9 mm x 3.0 m  | 6    | 24 (4 sets)   | 4975364 055064 | 3,200 (480/pc)                      |

# INDEX

| Item Code      | Page |                 |         |                   |         |
|----------------|------|-----------------|---------|-------------------|---------|
| 305D60/A1      | 49   | CNV-JUST/Y1     | 84      | DK-BD120-EUR      | 60      |
| 500C40/A1      | 47   | CONVEX-SET1     | 12 • 35 | DK-BT70-EUR       | 60      |
| 501A40/A1      | 47   | CPG175B/Y1      | 57      | DKC-L590W-EUR     | 40 • 61 |
| 520H40/A1      | 48   | CR201R-D1       | 88      | DK-FKSD-EUR       | 58      |
| 521H40/A1TAG   | 48   | CR301JF/D1      | 88      | DK-MSFHS-EUR      | 59      |
| <b>A</b>       |      | CR401S/D1       | 87      | DKTN80X/W1        | 59      |
| AC500S-EUR     | 38   | CR503S-D1       | 87      | DK-TNMN-EUR       | 59      |
| AC501S-EUR     | 38   | CR604S-D1       | 87      | <b>E</b>          |         |
| AC700S-EUR     | 38   | CTGSL300/K1     | 55      | EA-50HC           | 28      |
| AC701S-EUR     | 38   | CTGSL600/K1     | 55      | EE3-10HC          | 33      |
| ALB-A210FB     | 76   | CTGSL1000/K1    | 55      | EH-20HC           | 31      |
| ALB-A240FB     | 76   | <b>D</b>        |         | EL-50HC           | 29      |
| ALOR-A210FB-EU | 75   | DC50SFC/Y1      | 35 • 37 | EPK10MW1E01       | 22      |
| ALOR-A240FB-EU | 75   | DC360Y-EUR      | 36      | EPK10MW2E01       | 22      |
| ALSA-A210FB-EU | 75   | DC395BK-EUR     | 50      | EPK10MW3E10       | 22      |
| ALSA-A240FB-EU | 75   | DC560RB13D12/Y1 | 36      | EPK10MW4E01       | 22      |
| <b>C</b>       |      | DC560Y-EUR      | 36      | EPK20MW1E01       | 22      |
| CB62H/B1       | 30   | DC561RB13D12/Y1 | 36      | EPK20MW2E01       | 22      |
| CB65RBC/K1     | 32   | DC561Y-EUR      | 36      | EPK20MW3E10       | 22      |
| CB93H/Y1       | 54   | DC610-Y1-10     | 45      | EPK20MW4E01       | 22      |
| CLP160B/Y1     | 56   | DC660W-EUR      | 43      | EPK30MW1E10       | 22      |
| CLP210B/Y1     | 56   | DC661W-EUR      | 43      | EPK30MW3E10       | 22      |
| CNV100LT/K1    | 85   | DC680-Y1-10     | 45      | EPK30MW4E01       | 22      |
| CNV100RS/B1    | 83   | DC690-Y1-10     | 44      | <b>G</b>          |         |
| CNV100SP12/R1  | 84   | DFC560W-EUR     | 34      | G3GLM27-50EB-EUR  | 12      |
| CNV100SP26/R1  | 83   | DFC561W-EUR     | 34      | G3GLM27-80EB-EUR  | 12      |
| CNV900SP26-R1  | 83   | DFC579-SY-EUR   | 35      | G3GLWM25-50EB-EUR | 10      |
| CNVBSP3W550/R1 | 82   | DFC670-SW-EUR   | 39      | GAG3L25-50D-EUR   | 6       |
| CNV-FSP600-R1  | 82   | DFC671-SW-EUR   | 39      | GAG3L27-75D-EUR   | 6       |
| CNVJ900/YEUSA  | 85   | DKBB50B/W1      | 61      | GASP25-50EB-EUR   | 7       |

# INDEX

| Item Code      | Page |              | Page |               | Page |
|----------------|------|--------------|------|---------------|------|
| GKBG210/-1     | 77   | HTN50MW3A10  | 21   | LC520Y-EUR    | 48   |
| GKBG240/-1     | 77   | <b>J</b>     |      | LC521Y-EUR    | 48   |
| GKG210B/K1     | 76   | JPR265AFB-R1 | 71   | LC560Y-EUR    | 42   |
| GKG240B/K1     | 76   | JPR265A/R1   | 71   | LC561Y-EUR    | 42   |
| GL16-30E-EUR   | 14   | JPR265C/-1   | 72   | LC620Y-EUR    | 48   |
| GL19-50EB-EUR  | 14   | JPR265D/K1   | 71   | LC650Y-EUR    | 47   |
| GL25-50D-EUR   | 15   | JPR265FBR/Y1 | 72   | LC660Y-EUR    | 42   |
| GL25-50EB-EUR  | 14   | JPR265R/Y1   | 72   | LC661Y-EUR    | 42   |
| GL25-70EB-EUR  | 14   | JPR265ST/-1  | 73   | LC959X/Y1     | 54   |
| GL25-75D-EUR   | 15   | JPR300A/R1   | 71   | LCB30C/Y1     | 28   |
| GL25-80EB-EUR  | 14   | JPR300/K1    | 71   | LCB30RBC/K1   | 28   |
| GL25-100D-EUR  | 15   | <b>L</b>     |      | LCB30SC/Y1    | 28   |
| GL25-100EB-EUR | 14   | L16-30E1-EUR | 8    | LCB50C/Y1     | 29   |
| GLM25-50EB-EUR | 15   | L16-30E-EUR  | 16   | LCB50DC/Y1    | 29   |
| GLPYR-SET2     | 14   | L16-50E-EUR  | 16   | LCB50RBC/K1   | 30   |
| GLPYR-SET3     | 14   | L19-50EB-EUR | 16   | LCB50SN/YE    | 29   |
| GNB250P/-1     | 73   | L25-50E1-EUR | 8    | LCB65C/Y1     | 31   |
| GNB265FBP/-1   | 73   | L25-50EB-EUR | 16   | LCB65N/Y1     | 31   |
| GNB265P/-1     | 73   | L25-70EB-EUR | 16   | LCB65RBC/K1   | 32   |
| GNB265STP/-1   | 73   | L25-100E-EUR | 16   | LCB65S-10H/Y1 | 31   |
| GNB300P/-1     | 73   | LB30N/-1     | 28   | LCM500BK-EUR  | 41   |
| <b>H</b>       |      | LB50N/-1     | 29   | LKT-F02R      | 19   |
| H13-20EN-EUR   | 17   | LC301-EUR    | 49   | LKT-F05R      | 19   |
| HKB-10B/Y1     | 52   | LC303B-EUR   | 46   | <b>M</b>      |      |
| HKB-50B/Y1USA  | 52   | LC303Y-EUR   | 46   | MG300FB/REEU  | 71   |
| HSP30MW3A10    | 21   | LC390-EUR    | 51   | <b>N</b>      |      |
| HSP50MW3A10    | 21   | LC500B-EUR   | 47   | N-G165FS-EUR  | 78   |
| HTN30MW2A01    | 21   | LC500Y-EUR   | 47   | N-G165JS-K1   | 79   |
| HTN30MW3A10    | 21   | LC501B-EUR   | 47   | NK-G165FS-EUR | 78   |
| HTN50MW2A01    | 21   | LC501Y-EUR   | 47   | NK-G165JS-1   | 79   |

# INDEX

| Item Code     | Page |                    | Page |               | Page |
|---------------|------|--------------------|------|---------------|------|
| NMY13-20D-EUR | 18   | SCRL200/Y1         | 67   | <b>V</b>      |      |
| <b>P</b>      |      | SCRL300/Y1         | 67   | VR101R-EUR    | 53   |
| PHR250F80/W1  | 64   | SCRL600/Y1         | 67   | VR102B-EUR    | 53   |
| PHR250H80/W1  | 65   | SCRM75/Y1          | 67   | VR103S-EUR    | 53   |
| PHR500H80/W1  | 65   | SCRN95/Y1          | 66   | VRB2-10B/Y1   | 52   |
| PHR-FB80/-1   | 65   | SF-BHLD-EUR        | 11   | VRB2-50B/Y1   | 52   |
| PHR-HB80/-1   | 65   | SFG3GLWM2570EB-EUR | 11   | VRB2-100B/Y1  | 52   |
| PIT-10C-EUR   | 18   | SLT100/-E          | 91   | <b>Z</b>      |      |
| PIT-20C-EUR   | 18   | SLTAL200M/K1       | 91   | ZL25-50EB-EUR | 13   |
| PIT-30FRC-EUR | 18   | SS001/Y1           | 32   | ZL25-80EB-EUR | 13   |
| PIT-50C-EUR   | 18   | SSS16-30EB-EUR     | 9    |               |      |
| PL-ITO3L-1    | 88   | SSS19-50EB-EUR     | 9    |               |      |
| PLITOL-EUR    | 88   | SYL30MTBG01E       | 24   |               |      |
| PLITOLL-1     | 88   | SYL50MT3G15        | 24   |               |      |
| PLITOS-EUR    | 88   | SYR30MT3G15        | 24   |               |      |
| PSCL300A/W1   | 63   | SYR50MT3U15TAG     | 24   |               |      |
| PSCL300F/W1   | 62   | SYS20MT2E01E       | 25   |               |      |
| PSCL500A/W1   | 63   | SYS20MT3U15TAG     | 25   |               |      |
| PZB300Y/D1    | 93   | SYS50MT3B15        | 25   |               |      |
| PZB400GPY/D1  | 92   | <b>T</b>           |      |               |      |
| PZB400Y/D1    | 93   | TBK120H45/R1       | 89   |               |      |
| <b>R</b>      |      | TBK180H45/R1       | 89   |               |      |
| RBA-50HC      | 28   | TBYD180/-1         | 90   |               |      |
| RBE3-10HC     | 33   | TOP13-20EK-EUR     | 17   |               |      |
| RBH-20HC      | 32   | TOP13-20N-EUR      | 17   |               |      |
| RBL-50HC      | 30   | TOP13-30EK-EUR     | 17   |               |      |
| <b>S</b>      |      | TOP13-35EK-EUR     | 17   |               |      |
| SCRC50/Y1     | 66   | TOP13-35N-EUR      | 17   |               |      |
| SCRC75/Y1     | 66   | TOP13-50EK-EUR     | 17   |               |      |
| SCRH1200/Y1   | 67   | TOP13-55N-EUR      | 17   |               |      |

# PROPOSITION DE PRÉSENTOIRS ATTRACTIFS.

## ATTRACTIVE DISPLAY PROPOSAL

Pour les actions promotionnelles  
For Product Presentation

### Présentoir

Display



500 mm

2200 mm



2280 mm

1050 mm

420 mm



140 mm

DS-100

165 mm

225 mm



350 mm

DS-201

550 mm

250 mm



350 mm

350 mm

820 mm

### Présentoir : G Lock Pyramid

Display : G Lock Payramid Set



320 mm

320 mm

395 mm

GLPYR-SET2



320 mm

320 mm

395 mm

GLPYR-SET3

# PROPOSITION DE PRÉSENTOIRS ATTRACTIFS.

## ATTRACTIVE DISPLAY PROPOSAL

---

### Drapeau

Banner



### Autocollants Logo TAJIMA

TAJIMA Logo Stickers



# Tajima

Fondé en 1909 en tant que fabricant de mesures en acier et en fibre, TJM Design Corporation produit de nos jours plus 1.000 références d'outils à main haut de gamme sous la marque Tajima. Devenue une entreprise multinationale par ses facilités de production, TJM Design Corporation poursuit son implication dans l'excellence du design, la sélection des matières ainsi les contrôles de qualité qui caractérisent le processus de fabrication de ses outils. Et l'ensemble des collaborateurs de TJM Design Corporation sont concentrés pour s'assurer que la fonction, la qualité, la forme et le design des outils Tajima soient à la hauteur des attentes des utilisateurs. C'est pourquoi, la marque d'outillage Tajima est reconnue dans le monde entier comme offrant des caractéristiques fonctionnelles à un niveau élevé de qualité, devenu rare aujourd'hui.

Founded in 1909 as a manufacturer of steel and woven measuring tapes, TJM Design Corporation now produces over 1,000 premium-grade hand tools under the Tajima brand. A multinational organization with global production facilities, TJM Design Corporation continues its commitment to excellence in the design, selection of materials, production and quality control processes that govern the manufacture of its tools. And all TJM Design Corporation staff are dedicated to ensuring that the function, quality, shape and design of Tajima tools fulfills the desires and expectations of the end user. As a result, Tajima brand tools are recognized worldwide as offering exceptional feature and function at a high level of quality rarely seen in today's industry.



# Tajima

## TJM Design Corp.

3-4-3 Azusawa  
Itabashi-ku, Tokyo 174-8503 Japan  
Tel: +81-3-3969-6603  
Fax: +81-3-3969-7402

No.FGB 1100 January, 2026  
Printed in Japan

## TAJIMA AG TAJIMA TOOL EUROPE

Stansstaderstrasse 54  
CH-6370 Stans Suisse  
[www.tajima.eu.com](http://www.tajima.eu.com)  
Tel: +41 41 619 7010  
Fax: +41 41 619 7011  
[info@tajima.eu.com](mailto:info@tajima.eu.com)



@tajimatoolseurope



@TAJIMATOOLEUROPE